

---

Theses and Dissertations

---

2012

# The moderating role of child temperament in the relation between harsh and deficient parenting and child aggressive behaviors

Nizete-Ly Valles  
*University of Iowa*

Copyright 2012 Nizete-Ly Valles

This dissertation is available at Iowa Research Online: <http://ir.uiowa.edu/etd/3396>

---

## Recommended Citation

Valles, Nizete-Ly. "The moderating role of child temperament in the relation between harsh and deficient parenting and child aggressive behaviors." PhD (Doctor of Philosophy) thesis, University of Iowa, 2012.  
<http://ir.uiowa.edu/etd/3396>.

---

Follow this and additional works at: <http://ir.uiowa.edu/etd>

 Part of the [Psychology Commons](#)

THE MODERATING ROLE OF CHILD TEMPERAMENT IN THE RELATION  
BETWEEN HARSH AND DEFICIENT PARENTING AND CHILD AGGRESSIVE  
BEHAVIORS

by  
Nizete-Ly Valles

An Abstract

Of a thesis submitted in partial fulfillment  
of the requirements for the Doctor of  
Philosophy degree in Psychology  
in the Graduate College of  
The University of Iowa

July 2012

Thesis Supervisor: Professor John F. Knutson

## ABSTRACT

Child temperament has been implicated as a possible mediator or moderator of the relation between parenting and child outcomes. However, previous studies have led to ambiguous interpretation of the results due to methodological problems. Sanson et al., (2004) conducted a review of the relation between temperament and social development and outlined four methodological problems with previous research in the field of temperament: 1) the genetic link between parents and children, 2) the use of parental report for both child temperament and parenting behaviors, 3) lack of controlling for earlier parenting history, and 4) the use of correlational data. The present study was designed to address the first two methodological problems. The present study examined the moderating role of the three broad child temperament factors on the relation between three forms of parenting practices: punitive discipline, deficient parenting, and poor parental monitoring and child aggressive behavior. Using a multimethod and multisource design, parent report, child report, direct observational data, and behavioral tasks were used to create the construct when possible. The behavioral tasks used to assess negative affectivity were a modified “Locked Box” task (Lab-Tab; Goldsmith, Reilly, Lemery, Longley, & Prescott, 1993) and the Impossible Puzzle task (Burhans & Dweck, 1995; Smiley & Dweck, 1994). For effortful control, the Stroop test and a simplified “Go/No-Go” task were used (Stroop, 1935; Suskauer, Simmonds, Fotedar, Blankner, Pekar, Denckla, et al., 2008). The present study also controlled for other factors that have been linked to child aggressive behaviors, including, child age and gender, maternal personality, and economic disadvantage. Child aggression criteria based on mother report and child report were examined separately using hierarchical regression and full information maximum likelihood estimation in path analyses. Three hypotheses were tested: 1) high levels of child negative affectivity will moderate the relation between harsh/punitive discipline and the development of aggressive behavior problems, 2) a

combination of inconsistent discipline and neglect, or deficient parenting, will predict aggressive behaviors in children with high levels of surgency, and 3) poor maternal monitoring will predict aggressive behaviors for children low on effortful control.

Results using child report of aggressive behaviors indicated that temperament did not moderate the relation between parenting practices and aggressive behavior; however, higher use of punitive discipline predicted higher levels of aggressive behavior. The covariates, age and maternal positive emotionality, predicted aggressive behavior as well, with older children reporting higher rates of aggression and higher levels of maternal positive emotionality predicting lower levels of aggressive behavior in children. Using maternal report of aggressive behaviors, deficient parenting had a main effect on child aggressive behavior, with higher use of deficient parenting predicting greater aggressive behavior in children. While temperament did not moderate the relation between parenting and aggressive behavior using maternal report either, effortful control did have a main effect on aggressive behaviors. That is, higher levels of effortful control predicted lower levels of child aggressive behavior. The covariate maternal negative emotionality also predicted higher levels of mother reported child aggressive behaviors. In summary, although unable to find a moderation effect for temperament, this study found support for the role of harsh punitive discipline and deficient parenting as risk factors in the aggressive behavior of children and found support for effortful control and maternal positive emotionality as protective factors against child aggressive behavior. Results are interpreted in terms of treatment for child aggression and the need to obtain data from different sources in a non-aggregated manner.

Abstract Approved: \_\_\_\_\_  
 Thesis Supervisor  
 \_\_\_\_\_  
 Title and Department  
 \_\_\_\_\_  
 Date

THE MODERATING ROLE OF CHILD TEMPERAMENT IN THE RELATION  
BETWEEN HARSH AND DEFICIENT PARENTING AND CHILD AGGRESSIVE  
BEHAVIORS

by  
Nizete-Ly Valles

A thesis submitted in partial fulfillment  
of the requirements for the Doctor of  
Philosophy degree in Psychology  
in the Graduate College of  
The University of Iowa

July 2012

Thesis Supervisor: Professor John F. Knutson

Copyright by  
NIZETE-LY VALLES  
2012  
All Rights Reserved

Graduate College  
The University of Iowa  
Iowa City, Iowa

CERTIFICATE OF APPROVAL

---

PH.D. THESIS

---

This is to certify that the Ph.D. thesis of

Nizete-Ly Valles

has been approved by the Examining Committee  
for the thesis requirement for the Doctor of Philosophy  
degree in Psychology at the July 2012 graduation.

Thesis Committee: \_\_\_\_\_  
John F. Knutson, Thesis Supervisor

\_\_\_\_\_  
Jodie Plumert

\_\_\_\_\_  
Grazyna Kochanska

\_\_\_\_\_  
Kristian Markon

\_\_\_\_\_  
Molly Nikolas

## ACKNOWLEDGMENTS

This research was supported in part, by grant RO1 MH 61731 funded by NIMH and ACYF, and, in part, by grant R01 HD-46789 funded by NICHD and by a research grant awarded by the Executive Council of Graduate and Professional Students at the University of Iowa. The facilitation of the research was made possible by Barry Bennett, Cheryl Whitney, Marc Batey, Mark Schmidt, and Wayne McCracken (Iowa Department of Human Services). I would like to thank Drs. John F. Knutson, Grazyna Kochanska, Kristian Markon, Jodie Plumert, David Watson, and Molly Nikolas for their guidance. I also thank Drs. Robin Barry, Amanda Murray, Nicole Shay, and Sarah Taber, as well as many undergraduate research assistants who assisted with data collection. A special thank you to Kaj Björkqvist, for permitting a modified use of the Direct and Indirect Aggression Scale.



## ABSTRACT

Child temperament has been implicated as a possible mediator or moderator of the relation between parenting and child outcomes. However, previous studies have led to ambiguous interpretation of the results due to methodological problems. Sanson et al., (2004) conducted a review of the relation between temperament and social development and outlined four methodological problems with previous research in the field of temperament: 1) the genetic link between parents and children, 2) the use of parental report for both child temperament and parenting behaviors, 3) lack of controlling for earlier parenting history, and 4) the use of correlational data. The present study was designed to address the first two methodological problems. The present study examined the moderating role of the three broad child temperament factors on the relation between three forms of parenting practices: punitive discipline, deficient parenting, and poor parental monitoring and child aggressive behavior. Using a multimethod and multisource design, parent report, child report, direct observational data, and behavioral tasks were used to create the construct when possible. The behavioral tasks used to assess negative affectivity were a modified “Locked Box” task (Lab-Tab; Goldsmith, Reilly, Lemery, Longley, & Prescott, 1993) and the Impossible Puzzle task (Burhans & Dweck, 1995; Smiley & Dweck, 1994). For effortful control, the Stroop test and a simplified “Go/No-Go” task were used (Stroop, 1935; Suskauer, Simmonds, Fotedar, Blankner, Pekar, Denckla, et al., 2008). The present study also controlled for other factors that have been linked to child aggressive behaviors, including, child age and gender, maternal personality, and economic disadvantage. Child aggression criteria based on mother report and child report were examined separately using hierarchical regression and full information maximum likelihood estimation in path analyses. Three hypotheses were tested: 1) high levels of child negative affectivity will moderate the relation between harsh/punitive discipline and the development of aggressive behavior problems, 2) a

combination of inconsistent discipline and neglect, or deficient parenting, will predict aggressive behaviors in children with high levels of surgency, and 3) poor maternal monitoring will predict aggressive behaviors for children low on effortful control.

Results using child report of aggressive behaviors indicated that temperament did not moderate the relation between parenting practices and aggressive behavior; however, higher use of punitive discipline predicted higher levels of aggressive behavior. The covariates, age and maternal positive emotionality, predicted aggressive behavior as well, with older children reporting higher rates of aggression and higher levels of maternal positive emotionality predicting lower levels of aggressive behavior in children. Using maternal report of aggressive behaviors, deficient parenting had a main effect on child aggressive behavior, with higher use of deficient parenting predicting greater aggressive behavior in children. While temperament did not moderate the relation between parenting and aggressive behavior using maternal report either, effortful control did have a main effect on aggressive behaviors. That is, higher levels of effortful control predicted lower levels of child aggressive behavior. The covariate maternal negative emotionality also predicted higher levels of mother reported child aggressive behaviors. In summary, although unable to find a moderation effect for temperament, this study found support for the role of harsh punitive discipline and deficient parenting as risk factors in the aggressive behavior of children and found support for effortful control and maternal positive emotionality as protective factors against child aggressive behavior. Results are interpreted in terms of treatment for child aggression and the need to obtain data from different sources in a non-aggregated manner.

## TABLE OF CONTENTS

LIST OF TABLES .....	vii
LIST OF FIGURES .....	viii
CHAPTER I GENERAL OVERVIEW .....	1
CHAPTER II TEMPERAMENT AND AGGRESSIVE BEHAVIORS .....	3
CHAPTER III ENVIRONMENTAL CONTRIBUTIONS TO AGGRESSIVE BEHAVIORS .....	8
CHAPTER IV TEMPERAMENT, ENVIRONMENT, AND CHILDHOOD OUTCOMES .....	11
CHAPTER V METHODOLOGICAL PROBLEMS OF PREVIOUS RESEARCH .....	18
Overview of the Present Study .....	24
CHAPTER VI METHOD .....	26
Participants .....	26
Procedures.....	28
Measures .....	29
The Children’s Behavior Questionnaire (CBQ).....	29
Child Negative Affectivity Laboratory Tasks .....	30
Coding of Negative Affectivity Tasks. ....	31
Behavioral Tasks of Effortful Control.....	32
Measures of Parenting, Child Temperament, and Child Aggression Constructs .....	34
Harsh Punitive Discipline Construct.....	34
Maternal Monitoring Construct.....	36
Deficient Parenting Construct .....	38
Children’s Negative Affectivity Construct.....	39
Children’s Surgency Score.....	40
Children’s Effortful Control Construct .....	40
Children’s Aggressive Behaviors.....	40
Measures of the Covariate Constructs .....	41
Social Status Construct.....	41
Maternal Personality Construct.....	42
CHAPTER VII RESULTS .....	43
Preliminary Analyses.....	43
Testing Main and Interaction Effects of Parenting and Temperament on Aggressive Behaviors .....	46
Testing Main and Interaction Effects of Parenting and Temperament on Aggressive Behaviors Using Path Analyses.....	48
Post-Hoc Analyses Using Maternal Report of Child Aggression .....	51
Testing Main and Interaction Effects of Parenting and Temperament on Maternal Report of Child Aggressive Behaviors .....	51
Testing Main and Interaction Effects of Parenting and Temperament on Maternal Report of Aggressive Behaviors Using Path Analyses .....	53

CHAPTER VIII DISCUSSION .....	69
Parenting and Aggressive Behaviors .....	69
Child Temperament and Child Aggressive Behaviors .....	73
Age, Social Status, Maternal Personality, and Aggressive Behaviors .....	77
Conclusions.....	81
REFERENCES .....	83

## LIST OF TABLES

Table 1: Correlations Among Covariates, Predictors, and Child Report of Aggression .....	56
Table 2: Children’s Negative Affectivity as a Moderator of Harsh Discipline and Children’s Report of Aggressive Behaviors. ....	57
Table 3: Children’s Surgency as a Moderator of Deficient Parenting and Children’s Report of Aggressive Behaviors. ....	58
Table 4: Children’s Effortful Control as a Moderator of Maternal Monitoring and Children’s Report of Aggressive Behaviors. ....	59
Table 5: Children’s Negative Affectivity as a Moderator of Harsh Punitive Discipline and Maternal Report of Aggressive Behaviors. ....	60
Table 6: Children’s Surgency as a Moderator of Deficient Parenting and Maternal Report of Aggressive Behaviors. ....	61
Table 7: Children’s Effortful Control as a Moderator of Maternal Monitoring and Maternal Report of Aggressive Behaviors.....	62

## LIST OF FIGURES

Figure 1: Main and Interaction Effects of Punitive Discipline and Child Negative Affectivity .....	63
Figure 2: Main and Interaction Effects of Deficient Parenting and Child Surgency .....	64
Figure 3: Main and Interaction Effects of Maternal Monitoring and Child Effortful Control .....	65
Figure 4: Main and Interaction Effects of Punitive Discipline and Child Negative Affectivity Using Mother Report of Child Aggression .....	66
Figure 5: Main and Interaction Effects of Deficient Discipline and Child Surgency Using Mother Report of Child Aggression.....	67
Figure 6: Main and Interaction Effects of Maternal Monitoring and Child Effortful Control Using Mother Report of Child Aggression .....	68

## CHAPTER I

### GENERAL OVERVIEW

Childhood externalizing disorders (i.e., Attention-Deficit/Hyperactivity Disorder, Oppositional Defiant Disorder, and Conduct Disorder) have received substantial research attention due to their link to juvenile and adult criminal offenses and other antisocial behaviors (e.g., Loeber & Stouthamer-Loeber, 1998; Moffitt, 1993; Moffitt, 2003, Patterson, DeGarmo, & Knutson, 2000). Consequently, research has been dedicated to the early identification of children at risk for later externalizing problems (c.f., Campbell, Shaw, & Gilliom, 2000). More specifically, research examining the early identification of children at risk for externalizing behavioral problems often finds that these children have a history of early age aggressive behaviors (Jaffee, 2002; Moffitt, Caspi, Harrington, & Milne, 2002; Seguin, Boulerice, Harden, Tremblay, & Pihl, 1999). For instance, Tremblay and colleagues have found strong relations between early onset—and persistent—aggressive behaviors and future conduct problems (Nagin & Tremblay, 1999). Furthermore, aggression coupled with other behavioral problems such as ADHD increases the severity of the disorder (Campbell et al., 2000). Therefore, given that child aggressive behaviors are strong predictors of later maladjustment, the identification of person and process factors that potentiate risk for aggressive behaviors merits research attention. For the purposes of this study, aggression is defined as direct attacks that are often “visible, disruptive, and frightening even to the spectators” (Salmivalli, Kaukiainen, & Lagerspetz, 2000, p.18). Given this particular definition, both physical forms of aggression (e.g., hitting, kicking, taking items from another child) and verbal forms of aggression (e.g., name calling, yelling/screaming at another child) will be considered.

Previously identified predictors of aggressive behaviors include environmental/contextual factors such as harsh punitive discipline, inconsistent discipline (Bates, Pettit, & Dodge, 1995; National Institute of Child Health and Human Development [NICHD] Early Child Care Research Network, 2004; Knutson, DeGarmo, Koepl, & Reid, 2005), as well as economic disadvantage and parental characteristics of maternal psychopathology (e.g., maternal depression) and maternal personality (Kochanska, Clark, & Goldman, 1997; Moffitt, 2003; Tremblay, 2000). Importantly, children are not viewed as passive recipients of those environmental/contextual factors, as it is now understood that children play a crucial role in their socialization (Sanson, Hemphill, & Smart, 2004). For example, early research on temperament focused on the direct links of child temperament and outcomes, while more recent research examines the possible interactions between the child and their environment (Sanson et al., 2004). Child characteristics that are commonly examined in consideration of these interactions include age, gender, prior aggressive behaviors, and most importantly, temperament (Rothbart, Ahadi, Hershey, & Fisher, 2001; Rothbart, 2007). As such, the examination of children's temperamental predispositions (e.g., low effortful control) as putative predictors of aggressive behaviors has become a promising field of research (e.g., Eisenberg, Fabes, Nyman, Bernzweig, & Pinuelas, 1994, Frick & Morris, 2004; Kochanska & Knaack, 2003; Lengua, 2006; Moffitt, 2003, Rothbart & Ahadi, 1994; Rothbart & Bates, 1998; Rothbart & Putnam, 2002; Sanson et al., 2004). Therefore, a goal of the current study is to examine the main effects of different types of deficient parenting on child aggressive behaviors, while also examining the possible moderating role of child temperament.



## CHAPTER II

### TEMPERAMENT AND AGGRESSIVE BEHAVIORS

Temperament is defined by Rothbart and colleagues as affective and regulatory (e.g., behavioral and attentional regulation) biological systems that emerge early in an infant's development and remain relatively stable (Rothbart et al., 2001; Rothbart & Bates, 1998). For the purposes of this study, Rothbart and colleagues' definition was chosen since it incorporates both affective and nonaffective systems, both of which are hypothesized to play a significant role in the development of child behavior problems (Rothbart & Derryberry, 1981). The affective or reactive systems of positive and negative affectivity have been linked to the primary emotions of joy, anger, and sadness (Rothbart et al., 2001); while the regulatory system emerges to modulate the expression of affect to meet specific task demands (Rothbart & Putnam, 2002; Rothbart et al., 2001). Although the examination of the structure of temperament is relatively recent (Caspi, Roberts, & Shiner, 2005) these reactive and regulatory systems have been further categorized into three broad factors, which are related to the factors found in adult personality research: 1) Negative Affectivity (similar to Neuroticism), 2) Surgency-Extraversion (related to Positive Affect), and 3) Effortful Control (similar to adult Constraint; Rothbart et al, 2001; Rothbart, 2004; Tellegen, 1985). Furthermore, prior research has established that each factor is differentially—and in combination—associated with expressions of childhood psychopathology.

The most commonly researched factor is Negative Affectivity, which is typically considered to be a child's general propensity to experience negative emotions of fear, anger, or sadness in response to stressors (Rothbart et al., 2001). This broad factor

consists of the midlevel traits of shyness, discomfort, fear, anger/frustration, sadness, and a reversed scored soothability scale (Rothbart et al., 2001). Negative affectivity has been shown to predict depression and anxiety (Lengua, West, & Sandler, 1998; Rothbart, 2004). However, negative affectivity has also been linked to the externalizing disorders. Using longitudinal data with children between the ages of 2 and 6 years, Gilliom and Shaw (2004) found that negative emotionality (i.e., difficultness and crying/fussing) predicted the early onset of externalizing behavior problems in boys, although other factors contributed to the persistence of the behavior problems. Interestingly, negative affectivity has been identified as the causal link between the comorbidity of externalizing and internalizing disorders (Krueger, Caspi, Moffitt, & Silva, 1998). Factor analytic methods have provided explanations as to how negative affectivity can contribute to both forms of behavioral problems. Results of factor analyses typically find that negative affectivity can be divided into two second-order factors: irritability/fear and anger/frustration, each which contributes differentially to childhood psychopathology (Lengua, 2006; Rothbart & Bates, 1998). Specifically, irritability/fear has been shown to predict internalizing disorders while anger/frustration has been shown to predict externalizing disorders (Eisenberg, Cumberland, Spinrad, Fabes, Shepard, Reiser, et al., 2001; Lengua, 2006). Thus, anger/frustration is particularly relevant to the aggressive behavior disorders as it appears to be a strong predictor of externalizing problems (Eisenberg et al., 2001; Lengua, 2006). The role of fear in the development of behavior problems is unclear, as it has been considered to be both a protective mechanism (Rothbart, 2004; Rothbart & Bates, 2006), as well as a risk factor (Oldehinkel, Hartman, DeWinter, Veenstra, & Ormel, 2004). That is, high levels of fear appear to predict low

levels of aggression, while also predicting internalizing disorders. However, a study by Colder, Lochman, and Wells (1997) found that high levels of fear predicted aggressive behaviors in boys when coupled with harsh discipline. Therefore, it appears that given circumstances of deficient and/or harsh parenting both lower-order factors could contribute to aggressive behaviors in children. One pathway could be aggression resulting from frustrative non-reward—a high anger/frustration pathway—and the other could be a fear based aggressive response, whereby children exposed to harsh/punitive discipline tend to interpret ambiguous situations as threatening (i.e., Dodge's social information processing model; Crick & Dodge, 1994; Dodge, Bates, & Pettit, 1990; Dodge & Coie, 1987; Dodge, Pettit, Bates, & Valente, 1995). Importantly, a study conducted by Oldehinkel et al (2004) found that the frustration component of negative affectivity is associated with the severity of both internalizing and externalizing disorders. The study examined four groups: a no disorders group, an internalizing disorders group, an externalizing disorder group, and a comorbid group. Results indicated that frustration increased as psychopathology increased with the comorbid group having higher frustration scores and also considered to be higher in severity. As such, negative affectivity is probably best viewed as a general risk factor for childhood psychopathology that may lead to aggressive behaviors when the child is placed in the context of a stressful environment (cf. Lengua et al., 1998).

Surgency-Extraversion is a child's propensity to experience positive emotions and approach (i.e., appetitive motivation; Rothbart, 2004). It is comprised of positive anticipation, high intensity pleasure/sensation seeking, activity level, impulsivity, smiling/laughter, and a negative loading for shyness. When examining the role of

surgency in childhood outcomes, it emerges as both a protective factor and as a risk factor in both internalizing and externalizing problems, depending on which midlevel trait is examined. That is, low levels of Surgency, specifically low activation levels, seems to predict depression (Rothbart, 2004). However, high levels of activity, which is a midlevel trait of Surgency, predicts externalizing problems in children but also predicts fewer internalizing problems (Karp, Serbin, Stack, & Schwartzman, 2004; Ormel, Oldehinkel, Ferdinand, Hartman, de Winter, & Veenstra, 2005; Rothbart & Putnam, 2002). Studies have also found that high levels of sensation seeking, another midlevel trait of Surgency, is predictive of externalizing disorders in school-aged children (e.g., Frick, O'Brien, Wotton, & McBurnett, 1994). When surgency is examined as a whole, high levels are also associated with aggressive behaviors, particularly aggressive behaviors linked to frustrative non-reward (Rothbart et al., 1994; Rothbart & Putnam, 2002). Furthermore, surgency (i.e., positive approach) has been linked to the emergence of another important factor of temperament, effortful control (Rothbart & Putnam, 2002).

Effortful Control is a child's ability to self-regulate behavior and attention, and consists of the midlevel traits of inhibitory control, attentional focusing, low intensity pleasure, and perceptual sensitivity (Rothbart, 2004). Effortful control is commonly defined as a child's ability to inhibit a dominant response to engage in a subdominant response that is more appropriate to the situation. Interestingly, effortful control emerges during the second year of a child's life and low levels of effortful control have been primarily linked to the externalizing disorders (Eisenberg et al., 2001; Hill, Degnan, Calkins, & Keane, 2006; Oldehinkel et al., 2004). For instance, Kochanska & Knaack (2003), using multiple laboratory assessment points (e.g., ages 22, 33, and 45 months)

found that although hints of effortful control are found in toddlers younger than 2 years-old, it does not appear to become stable until 45 months. Also, children with difficulties regulating attention and inhibiting impulsive responses (i.e., low levels of effortful control) are at higher risk for developing attention problems, aggressive behaviors, and destructive behaviors (e.g., Caspi, Henry, McGee, Moffitt, & Silva, 1995; Kochanska & Knaack, 2003; Olson, Sameroff, Kerr, Lopez, & Wellman, 2005). Conversely, a high level of effortful control seems to be a protective factor against aggressive behaviors (Eisenberg et al., 1994; Lengua, 2006), while also predicting low levels of anxiety and depression (Lengua, 2006; Lonigan, Vasey, Phillips, & Hazen, 2004). Furthermore, when both anger/frustration and effortful control of the child are examined as possible predictors of externalizing disorders, effortful control has been found to incrementally contribute to the variance of externalizing behavior problems even after accounting for anger/frustration, social adversity (e.g., punitive discipline), and the intellectual status of the child (Kochanska & Knaack, 2003; Olson et al., 2005).

CHAPTER III  
ENVIRONMENTAL CONTRIBUTIONS TO AGGRESSIVE  
BEHAVIORS

Other avenues of research have focused entirely on the role of parenting on childhood outcomes. Parents have long been viewed as a child's primary socializing agents (Maccoby, 1992); therefore, the direct effects of both parenting styles and parental disciplinary strategies on childhood outcomes have been the focus of a wealth of research. Of particular interest is the effect of negative parenting behaviors such as harsh/punitive discipline, parental rejection, and low parental warmth on childhood disruptive behavior disorders (e.g., Conduct Disorder, Oppositional Defiant Disorder, and antisocial behaviors). For example, several studies have implicated corporal punishment as a mechanism of increased use of childhood aggressive behaviors via different but related processes (i.e., modeling Bandura & Walters, 1959, coercive parent-child relationship, Cloninger, Sigvardsson, Bohman, & von Knorring, 1982; Patterson, 1982). For example, Chang, Schwartz, Dodge, and McBride-Chang (2003), suggested that maternal use of spankings and scolding in response to child transgressions may communicate anger to the child, which leads to an emotional effect on the child. Gershoff (2002) conducted a meta-analysis examining the relation between corporal punishment and childhood outcomes. Overall, the author found support for the notion that corporal punishment—which did not include acts that could risk physical injury to the child—increases the risk of aggressive behaviors in children (Gershoff, 2002). Moreover, early childhood experiences with harsh physical discipline have been linked to negative outcomes, even in adolescence (Bender, Allen, Mcelhaney, Antonishak, Moore, Kelly, et al., 2007). Ineffective discipline, which is a combination of aversive parental

behaviors, inconsistency, and parental negative affect, has also been found to predict increases in aggressive behaviors over time (Snyder, Cramer, Afrank, & Patterson, 2005).

Other dimensions of parenting behavior have also been found to predict negative childhood outcomes. For example, a combination of high parental psychological control (i.e., use of guilt induction, manipulation) and high levels of behavior control (e.g., providing alternatives, limit setting, and monitoring) has been found to be associated with both internalizing and externalizing behaviors (Caron, Weiss, Harris, & Catron, 2006). The authors noted that even though behavior control strategies are typically considered to be effective forms of discipline, overuse of behavior control coupled with high levels of psychological control can lead to poor outcomes in children (Caron et al., 2006). However, in the Caron et al study, the parenting dimensions consisted of multiple parenting behaviors which were combined to create the dimensions. For example, the mother's use of hostile tone, emotional over involvement, and threats were combined to create the psychological control dimension; therefore, it is unclear which component(s) of the parenting dimensions are the effective predictors of behavior problems.

Negative experiences, such as neglect or abuse, during a child's development have also been linked to maladaptive behaviors. That is, children who have experienced neglect (either supervisory or care neglect) and physical abuse are at higher risk for developing externalizing disorders, particularly aggressive behaviors (Bates et al., 1995; Jaffee, Caspi, Moffitt, & Taylor, 2004; Knutson et al., 2005; Lansford, Dodge, Pettit, Bates, Crozier, & Kaplow, 2002). For instance, a longitudinal study by Lansford et al. (2002) found that physical maltreatment during early childhood predicted a host of problems in adolescence, including aggressive behaviors. A lack of parental knowledge

of their child's behaviors, also known as poor parental monitoring or supervisory neglect, has also been found to predict aggressive behaviors in children (Knutson et al., 2005; Patterson & Stouthamer-Loeber, 1989).

Importantly, social economic disadvantage has also been implicated as a strong predictor of negative childhood outcomes (Hill et al., 2006; Shaw, Keenan, & Vondras; 1994, see Gershoff, 2002, for a review). However, Knutson et al., (2005), using both observational data and parental report, found that the relation between social economic status and child aggressive behaviors was mediated by care and supervisory neglect and harsh/punitive discipline (e.g., spanking, yelling, and abusive discipline). Notably, Knutson et al did not include an assessment of childhood temperament. Therefore, although the direct effects of parenting on childhood outcomes is important, given that temperament is present early in development, it seems critically important to analyze the possible moderating effect that different levels of the broad childhood temperament factors have on the relation between parenting and aggressive behaviors in a sample of children at risk for aggressive behaviors.



## CHAPTER IV

### TEMPERAMENT, ENVIRONMENT, AND CHILDHOOD OUTCOMES

The majority of the research findings reviewed above lead to ambiguity in interpretation due to the sole focus of the independent effects of either temperament or contextual factors (e.g., Caron et al., 2006; Caspi & Silva, 1995; Eisenberg et al., 2001; Knutson et al., 2005; Oldehinkel et al., 2004). However, it has long been recognized that temperament or parenting alone do not lead to negative outcomes, but a combination of both “certain types” of environments and biologically determined temperamental dispositions can lead to internalizing and/or externalizing disorders in childhood (Bates, Pettit, Dodge, & Ridge, 1998; Cairns, 1979; Prior, 1992; Thomas & Chess, 1977). When temperament is viewed as underlying both future personality and psychopathology (Clark, 2005), it becomes critically important to examine what combinations of temperament and environments are predictive of negative outcomes in childhood. In an effort to advance the field, Rothbart (2004), called for the examination of both main effects *and* interaction effects of child temperamental characteristics and caregiving environments.

With the goal of examining interactive effects, previous studies have examined the mediating role of parenting and the moderating role of temperament *or* parenting. Studies that use mediation analysis implicate parenting as the proximal determinant of negative childhood outcomes (c.f., Snyder et al., 2005). Specifically, parenting has been found to reduce the direct relation between temperament and negative outcomes and the direct relation between psychosocial risk factors and temperament to nonsignificance. For example, poor parental discipline has been implicated as the shared mechanism for a

child's developmental transition from hyperactivity to antisocial behaviors (Patterson et al., 2000). That is, hyperactivity was directly associated with antisocial behaviors, but when parenting marked by nattering and harsh discipline was entered into the model, the direct effect between hyperactivity and antisocial behaviors was reduced to nonsignificance (Patterson et al., 2000). The relation between early childhood temperament and older child behavior problems has also been found to be mediated by harsh discipline (Dodge, 2002). Using a short-term longitudinal design (i.e., 6 months between baseline and follow-up), parental scaffolding and limit-setting mediated the relation between a cumulative risk index (i.e., a combination of demographic and psychosocial risk factors) and effortful control in preschool children (Lengua, Honorado, & Bush, 2007). Lengua et al (2007), found that a combination of environmental risk factors such as poverty, negative life events, and single parent household, exert their influence on effortful control through deficient parenting. The authors also found that while time one levels of effortful control predicted social competence, effortful control assessed 6 months later did not predict social competence, which was defined as having self-control, cooperation, and being assertive. Therefore, the authors argued that the levels (i.e., high, average, and low) of effortful control might be more informative than overall changes in effortful control, which would suggest that level of effortful control should be examined as a moderator of child outcomes.

As opposed to mediation analyses, moderation analyses allow for the examination of differential effects of potentially important variables, such as parenting practices. Thus, harsh and deficient parenting practices should differentially impact children depending on the child's level of the hypothesized temperamental risk factor. As an

example of such an analysis, Ramos, Guerin, Gottfried, Bathurst, and Oliver (2005), examined the moderating role of “difficult, easy, and intermediate” temperament style on the relation between family conflict and externalizing disorders. Results indicated that children with a “difficult” temperament style (i.e., negative mood, low approach, and low adaptability) coupled with family conflict during preschool years predicted school-age aggression and delinquency (Ramos et al., 2005). Also, the moderating role of temperament on the relation between other forms of deficient parenting (e.g., inconsistent discipline) and externalizing behaviors have been researched. For instance, Lengua, Wolchik, Sandler, and West (2000), found that inconsistent parenting predicted externalizing problems for children high on impulsivity, while parental rejection also predicted externalizing behaviors for children low on positive emotionality. Furthermore, Colder et al (1997) found that poor maternal monitoring of boys rated as highly active predicts aggressive behaviors, while fearful boys who experienced harsh discipline also had high levels of aggression. These results implicate child negative affectivity and effortful control, as well as different forms of deficient parental behaviors, in determining child aggressive behaviors (Colder et al., 1997). Also, the use of corporal punishment has been found to lead to conduct problems and property destruction for children who are high on impulsivity (Aucoin, Frick, & Bodin, 2006). Thus, it appears that if children are temperamentally predisposed to a range of difficult behavioral attributes, then their parents should adjust their disciplinary strategies to the specific child to facilitate appropriate socialization (e.g., learning to regulate strong emotions).

The seminal work by Kochanska and colleagues highlights the importance of considering both parental and child variables when examining the interactive effects of

parenting and child temperament. That is, Kochanska (1995) found that socialization is optimized when mothers take into consideration the child's level of fearfulness and self-regulation abilities when choosing disciplinary methods. For instance, if children are high on fear (i.e., highly anxious) then parents should use gentle disciplinary methods to help the child internalize parental standards of behavior. However, for "fearless" children, parents should capitalize on the parent-child relationship that is characterized by a mutually responsive orientation towards one another (Kochanska, 1995). Mutually responsive orientation is a type of relationship where there is reciprocal positive affect between the mother and the child, the mother uses minimal control efforts with the child, and there is an emphasis on the attachment relationship (Kochanska, 1995; Kochanska, Aksan, & Joy, 2007). A related study conducted by Stright, Gallagher, and Kelley (2008), found that children with "difficult" temperaments were also more likely to have better quality adjustment when they experienced high quality parenting, similar to children rated as having less difficult temperaments.

Also implicating a link between temperament and parenting in determining later aggression, aggressive behaviors in toddlerhood have been found to predict externalizing behaviors in preschool aged children. Importantly, the strongest relation was found for age-2 toddlers who received high levels of maternal negativity (i.e., hostility, rejection, and intrusion) and who were temperamentally dysregulated (Rubin, Burgess, Dwyer, & Hastings, 2003), which is another example of temperament as a moderating influence on parenting. Similarly, a study using latent growth analyses to examine latent interactions across 6 time points found that infants who received low levels of autonomy and emotional support were less likely to show school readiness skills (e.g., social skills,

positive relationships with peers) in 1<sup>st</sup> grade if those infants were rated high on a “difficult” temperament factor (Stright et al., 2008). Overall, studies examining the complex relation between parenting and child temperament in determining poor outcomes have found evidence for the notion that children who are exposed to inconsistent or harsh disciplinary strategies, as well as rejection or poor monitoring by mothers (i.e., poor parental supervision) are particularly at risk for negative outcomes, especially when that parenting is coupled with at-risk temperamental dispositions.

Parenting, however, has also been examined as a moderator between temperamental predispositions and negative outcomes. In one such study, Maziade, Caron, Côte, Merette, Bernier, Laplante, et al., (1990), using a sample of adolescents, found support for considering parenting that is dysfunctional and lacking in behavioral control as a moderator of the relation between “difficult” temperament (i.e., highly reactive children) at age 7 and risk of psychiatric disorders (e.g., Oppositional Defiant Disorder, Attention Deficit Hyperactivity Disorder) at ages 12 and 16. Another study examining externalizing behaviors conducted by Gilliom and Shaw (2004) found strong interactive effects for boys high on both negative emotionality and fearlessness and who also experienced high levels of negative maternal behavior control strategies (i.e., hostility, high levels of punitive discipline, critical statements). Conversely, parenting marked by restrictive control strategies such as negative commands, scolding, and toy restriction, was found to moderate the relation between resistance to control, which is a combination of surgency and negative affectivity, and externalizing disorders (Bates et al., 1998). Parenting behaviors other than harsh parenting—and more specific than merely “dysfunctional parenting”—have also been found to moderate the relation

between temperament and negative outcomes. For example, in a study examining behaviorally uninhibited children (ages 2-6), inconsistent parenting predicted low levels of guilt and empathy by children, while authoritarian parenting towards such children predicted high guilt (Cornell & Frick, 2007).

While the studies reviewed thus far have found significant effects for parenting as the moderator between child temperament and childhood outcomes, not all studies examining this relation do. For example, a study conducted by Vitaro, Barker, Boivin, Brendgen, and Tremblay (2006) examined harsh discipline as the moderator between negative emotionality and proactive and reactive aggression, and did not find interactive effects but only found additive effects. However, since both factors were assessed during early toddlerhood (i.e., 17 months) the authors concluded that interactive effects may emerge later in a child's life (Vitaro et al., 2006). For instance, a study conducted with 2 year-old children found that maternal hostility, rejection, and intrusion (i.e., maternal negativity) moderated the relation between conflict initiations at age 2 and age 4 externalizing behaviors. Thus, this study suggests that interactions between parenting and temperament might emerge by 4 years of age (Rubin et al., 2003).

A central question that arises from the literature is whether one should examine temperamental factors *or* parenting as the moderator or parenting as a mediator in determining childhood aggression? Since the present study uses concurrent data, child temperament will be examined as a moderator of the relation between different forms of harsh and deficient parenting and child aggressive behaviors. This conceptualization is consistent with a conditional model whereby the effect of different types of negative parenting practices on childhood aggressive behaviors will be determined by the level of

the child's temperamental risk factor (Gallagher, 2002; Nigg, 2006; Shiner & Caspi, 2003). This is essentially a susceptibility hypothesis (cf. Belsky, 2005) that states that parenting processes will exert stronger influences for children with specific vulnerabilities. This conceptualization is not inconsistent with studies that have found that children with "difficult to manage" behaviors seem to provoke the use of harsh discipline—but not physical abuse or maltreatment—from their parents (Jaffee, Caspi, Moffitt, Polo-Thomas, & Price, 2004). Thus, the primary goal of the present study is to examine how individual differences in temperament in preschool- and school-aged children and different types of negative parenting interact to predict aggressive behavior problems in a sample of children at risk for behavioral problems. The temperament factors being examined in the present study are negative affectivity, surgency/extraversion, and effortful control. The different types of negative parenting behaviors are: harsh/punitive discipline, deficient parenting—which is a combination of inconsistent discipline and lack of parental involvement—and poor maternal monitoring.

## CHAPTER V

### METHODOLOGICAL PROBLEMS OF PREVIOUS RESEARCH

Although existing research has helped elucidate the relation between temperament and negative child outcomes, methodological limitations within the temperament and parenting research still exist. For instance, Sanson et al., (2004) conducted a review of the relation between temperament and social development and outlined four methodological problems with previous research in the field of temperament: 1) the genetic link between parents and children, 2) the use of parental report for both child temperament and parenting behaviors, 3) lack of controlling for earlier parenting history, and 4) the use of correlational data. The present study was designed to address the first two methodological problems. A critical problem is the genetic link between the child and parent, which could account for the relation between parenting styles and aggressive behaviors (Sanson et al., 2004). Some studies have attempted to control for the genetic link by using a genetic proxy such as parental psychopathology (Hayden, Klein, & Durbin, 2005; Moffitt, 2003; Mun, Fitzgerald, Von Eye, Puttler, & Zucker, 2001; Pfiffner, McBurnett, Rathouz, & Judice, 2005). For example, Patterson et al. (2000) found that while parenting was the shared mechanism for a shift from hyperactivity to antisocial behaviors, the non-shared mechanism was having an antisocial parent. Having an antisocial parent was linked to antisocial behaviors in children but not to hyperactivity in children. In a similar study, Pfiffner et al (2005), identified paternal Antisocial Personality Disorder as a mediator of the relation between dysfunctional parenting and child conduct disorder. Therefore, these studies suggest that children of parents with



antisocial tendencies may be at increased risk for antisocial behaviors due to parental characteristics (Pfiffner et al., 2005).

Going beyond antisocial parents, other studies have used parental personality as predictors of parenting practices. Several studies have found support for high levels of maternal positive affect/extraversion being related to high levels of positive parenting (Kendler, Sham, & MacLean, 1997; Mangelsdorf, Gunnar, Kestenbaum, Lang, & Andreas, 1990). Other studies have examined the relation between maternal negative emotionality and parenting and have found that high levels of maternal negative emotionality are associated with the use of high power assertiveness and low responsiveness (Kochanska et al., 1997). Parental personality has also been found to be linked to both child temperament and parenting (e.g., Pedlow, Sanson, Prior, & Oberlkaid, 1993; Rothbart, 2004; Kochanska, 1995). Because temperament is at least partly heritable (Buss & Plomin, 1984; Goldsmith, Buss, & Lemery, 1997), and parents provide both the genes and the environment in which the child is reared (Jaffee, Caspi, Moffitt, & Taylor, 2004), the impact that maternal personality may have on both the independent variable (i.e., parenting) and the dependent variable (i.e., aggression), was controlled in the present study.

On a related note, confounding parental personality with parenting behaviors is also problematic. For example, the Vitaro et al., (2006) study that did not find interactive effects of child temperament and harsh parenting on aggressive behavior had an important confound. That is, the measure used to assess harsh parenting (i.e., Parental Cognitions and Conduct Toward the Infant Scale; PACOTIS) consisted of both disciplinary strategies (e.g., “I have raised my voice or shouted...”) and maternal

negative affect in response to the child's affective response (e.g., when my baby cries, he/she gets on my nerves). Therefore, the present study assessed deficient parenting, harsh/punitive discipline, and poor maternal monitoring focusing on specific parenting behaviors as opposed to items that may reflect parental personality traits manifested in parenting contexts but not explicitly parenting behaviors.

Another potential confound is the possibility that maternal ratings of child temperament could reflect the mother's recall of her child's reactions to discipline. For example, when punished, a child can respond by throwing a tantrum, whining/crying, becoming fearful, or even becoming aggressive—items that are typical of negative affectivity. To assess temperament it is important to determine the child's behavioral attributes in different contexts (Karp et al., 2004). Thus, temperament measures should be based on items that cover a wide range of contexts. Therefore, the temperament measure selected in the present study asked mothers to rate their child's behavior in specific contexts (e.g., “when practicing an activity, has a hard time keeping his/her mind on it,” “when outside, often sits quietly”), as opposed to global ratings of temperament (Else-Quest, Hyde, Goldsmith, & Van Hulle, 2006; Rothbart et al., 2001). Furthermore, the present study made use of observational and/or behavioral data to examine the child's temperament in a structured setting without the presence of his/her mother.

In addition, a large majority of previous research examining temperament and caregiving has relied on maternal ratings of both variables, which leads to shared method and source variance and/or the influence of parental bias (c.f. Sanson et al., 2004) on the outcome indices. Therefore, researchers have recommended the use of direct observational data as a more useful source of child behaviors and parenting (e.g., Karp et

al., 2004; Lengua, 2006). Consistent with those recommendations, the current study utilized a multimethod/multisource design. That is, different combinations of observational data, child report and maternal report were used to assess parenting, while behavioral tasks—when possible—and maternal report were used to assess temperament. Child report of aggressive behaviors was used for the criterion. Few studies have used both behavioral tasks and parental reports of temperament (e.g., Hayden et al., 2005; Karp et al., 2004; Kochanska, 1995; Kochanska et al., 2007; Rubin et al., 2003) because correlations between informants and methods are generally low (Valles & Knutson, 2008). However, prior studies have suggested that each informant may provide unique and valid information about the child's behavior in different contexts (Culp, Howell, Culp, & Blankemeyer, 2001; La Greca & Stone, 1992; Phares, 1997; Valles & Knutson, 2008). Therefore, even though the use of laboratory measures and parental reports has specific benefits and pitfalls, both appear to provide useful sources of information (Karp et al., 2004) and both were incorporated in the present research.

While an examination of child temperament appears to be a worthwhile effort for predicting future psychopathology or adjustment difficulty, such research is further constrained by particularized definitions of temperament (e.g., purely affective vs. affective and regulatory), inconsistent temperamental terminology (e.g., “difficult” temperament), and the overlap among behaviors considered to be psychopathology and those that fall under the rubric of indices of temperament (Else-Quest et al., 2006; Lengua et al., 1998; Nigg, 2006; Rothbart, 2004). Therefore, to understand how temperament impacts the relation between parenting and child outcomes, the present study opted to examine the effects of the broad temperament factors individually. That is, instead of

combining subscales of the different factors to create a “difficultness” factor (van Aken, Junger, Verhoeven, van Aken, & Dekovic, 2007), the present study examined negative affectivity, effortful control, and surgency/extraversion separately. Regarding the item overlap between temperament and psychopathology measures, similar items across measures can lead to inflated reported relations between temperament and aggressive behaviors (Sanson, Prior, & Kyrios, 1990). Problematically, the Aucoin et al., (2006) study used ADHD criteria from the Diagnostic and Statistical Manual—4<sup>th</sup> edition (DSM-IV; American Psychiatric Association, 2000) as a measure of temperamental impulsivity, which is equating diagnostic features of a behavioral disorder with temperament, despite studies that have found that ADHD can be distinguished from behavioral dysregulation and impulsivity (Nigg, Goldsmith, & Sachek, 2004).

Some studies have used statistical methods to remove item overlap (Lengua et al., 1998; Oldehinkel et al., 2004; Sanson et al., 1990). For instance, Lengua et al (1998) examined the relation among temperament, stress caused by parental divorce, and later adjustment problems. To assess adjustment problems, the authors used the Child Behavior Checklist, and to assess temperament they used the Emotionality, Activity, and Sociability scale for negative emotionality, the Dimensions of Temperament Survey—Revised for positive emotionality, and the Child Behavior Questionnaire for attentional focusing and impulsivity. The authors found significant item overlap between measures using confirmatory factor analyses (CFA) and subsequently conducted analyses using both the original measures and the measures without the overlapping items. The results of the study did not change depending on whether or not the overlap was removed (Lengua et al., 1998). That is, using both the contaminated and the uncontaminated

measures, negative emotionality predicted depression and conduct problems, positive emotionality predicted lower levels of depression and conduct problems, attention focusing predicted lower levels of conduct problems, and impulsivity predicted conduct problems (Lengua et al., 1998). To control for this potential pitfall, the measures used in the present study for assessing child temperament and child aggression did not contain overlapping items.

It is important to consider the impact that child age and gender can have on temperament, parenting, and aggressive behaviors. For example, with respect to temperament, some studies have shown that younger children—infants, toddlers, and preschool age—show lower levels of effortful control compared to older children (Kochanska & Knaack, 2003; Rothbart, 2004). Another study examining three temperament dimensions (i.e., impulsivity, fearfulness, and helpfulness) in a sample of children aged 6-12, found significant gender effects. Specifically, girls were found to be less impulsive, more helpful, and more fearful, while boys were found to be more impulsive and less helpful (Coté et al., 2002). Moreover, poor emotional regulation and inattention have been shown to predict a chronic course of externalizing behavior problems for preschool females, and inattention is a predictor of this same course for males (Hill et al., 2006). Therefore, it appears that gender differences in temperament and outcome associations may begin to appear once children reach preschool and school-age (Hill et al., 2006; Kochanska, Murray, & Harlan, 2000); however, it is unclear if this pattern is due to biological factors or socialization effects (Else-Quest et al., 2006). Moreover, a meta-analysis examining gender differences in the broad temperament

factors found that gender differences are greater for Effortful Control and small—but present—for Negative Affectivity and Surgency/Extraversion (Else-Quest et al., 2006).

Age and gender can also impact parental disciplinary strategies and reports of aggressive behaviors. That is, boys are more likely to be exposed to deficient and harsh/punitive discipline compared to girls, and younger children are more likely to experience harsh/punitive discipline than older children (Gallup, Moore, & Schussel, 1995; Jaffee, Caspi, Moffitt, Polo-Thomas, et al., 2004, Strauss & Stewart, 1999; see Gershoff, 2002, for a review of both of these effects). There is also evidence regarding age and gender differences in aggressive behaviors (e.g., Nagin & Tremblay, 2001; Björkqvist, Lagerspetz, & Kaukiainen, 1992), with boys using higher levels of physical aggression compared to girls, and the use of aggressive behaviors typically declining as children age (e.g., Tremblay, 2000). Furthermore, age differences appear when considering children's use of verbal aggression, with older children typically using verbal aggression more frequently when compared to younger children (Björqvist et al., 1992, Valles & Knutson, 2008). Therefore, given that age and gender differences can appear at different time points in development and the proposed sample consisted of a wide developmental age range and both boys and girls, the effects of age and gender on temperament, parenting, and aggressive behaviors were controlled.

#### Overview of the Present Study

The goal of the present study was to examine the moderator effects of temperament on the relation between several deficient parenting practices and child aggressive behaviors, using a multisource and multimethod approach to assessment. If temperament is defined as being biological, present at infancy, and as being stable but malleable in the presence of aversive parenting (Rothbart, 2004), then it would be most likely to determine the level of aggressive behaviors present in the current sample. In

other words, this conceptualization identifies temperament as the vulnerability, while negative parenting is the stressor (Nigg, 2006; Sanson & Prior, 1999). Although this study assessed child temperament and aggression at preschool and school age as opposed to infancy, studies have found that both temperament and aggressive behaviors tend to stabilize over this developmental period (e.g., Pedlow et al., 1993; Zahn-Waxler, Iannotti, Cummings, & Denham, 1990). Therefore, it is hypothesized that high levels of child negative affectivity will moderate the relation between harsh/punitive discipline and the development of aggressive behavior.

Few studies have examined the role of surgency/extraversion and parenting with respect to aggressive behaviors in children (Rothbart & Putnam, 2002). However, based on available evidence and given the subscales that comprise this temperamental trait, it is hypothesized that a combination of inconsistent discipline and neglect—which can exacerbate an active child's behaviors via lack of socialization—will predict aggressive behaviors in children with high levels of surgency/extraversion. With regards to effortful control, it is hypothesized that poor maternal monitoring will predict aggressive behaviors, particularly for children low on effortful control.

## CHAPTER VI

### METHOD

#### Participants

A total of 85 mothers of children between the ages of 5-10 ( $M = 7$  years 8 months,  $SD = 17$  months, females = 41, males = 44) recruited for an on-going longitudinal study examining family interactions and children's social development completed measures on their parenting strategies, their child's temperament and behavior. Families were recruited from two counties in Iowa characterized as either small urban areas or rural agricultural areas ( $n = 60$ ), as well as one rural county in North-Central Wisconsin ( $n = 25$ ). Racial breakdown for the sample of children, as reported by their mother, was 68% Caucasian, 12% African American, 18% Bi/Multiracial, and 2% other.

Families were eligible to participate in the on-going study if they received services from the Iowa Department of Human Services (IDHS) or the Oneida County Department of Social Services (OCDSS) in the three months prior to enrollment in the study and had a child between the ages of 4 and 8 years old. If the family had more than one child within the age range, the research assistants chose an eligible child at random. The state or county agency provided a quarterly list of families who had children in the required age range who were recipients of state and county services. Families with children who had been identified as neglected or physically abused were also included on the list. Children who were in an out-of-home placement, receiving intensive family-based treatment, or who were *known* to have been sexually abused were excluded from participating. Potential family participants were also identified through the monthly records of injurious domestic assault from the offices of the county attorneys. The



recruitment process was designed to enroll children who were considered to be a high-risk population (i.e., high-risk for aggressive behaviors) because of economic disadvantage and/or exposure to environmental stressors.

Parents of eligible children were contacted by mail informing them of their possible eligibility to participate in research for which they would receive compensation. Parents were instructed to contact the research study by telephone. Once the potential participant made contact, the research assistants asked two screening questions (i.e., “Do you have a child between the ages of 4 and 8 years old?” and “Have you received services from the state or county in the past 3 months?”). If both questions were answered affirmatively, then a visit to the home was scheduled. The informed consent and enrollment occurred during an initial in-home interview with the parent, which provided information for the deficient parenting construct used in the present study. All other variables were assessed in 4-5 laboratory sessions with the parent and the child. Mothers were compensated \$50 per session, including the initial informed-consent process, and children selected a toy valued at \$10 or \$10 cash at each laboratory session. The project was conducted under the aegis of The University of Iowa Institutional Review Board 02 and with a Certificate of Confidentiality issued by the National Institute of Child Health and Development (NICHD).

Studies that have also used the sample described in the present study have reported that, based on focus groups conducted prior to the study with samples drawn from the targeted population, about 50% actually receive and read the recruitment letter. Of those who receive and read the letter, about 50% actually contacted the research project to arrange an informed consent interview (Knutson, Taber, Murray, Valles, &

Koepl, 2010). Thus, approximately 25% of the potential subject families who were sent letters contacted the research project to participate. The estimate of a 50% response rate of actually receiving the recruitment letter is based on indirect evidence and it is impossible to actually determine how many parents actually read the letter. Of those who scheduled an initial informed consent interview, less than 1% declined to participate. Comparisons of demographics of the recruited sample with the population from which it was drawn suggested that the sample was largely representative of that population.

### Procedures

Since the parent project was designed as a longitudinal project obtaining data over the course of three annual assessments, after their first year of participation, participants returned to the laboratory for 3-4 sessions at each of two annual follow-up sessions. In the parent project the first year of participation was labeled the initial year, their second year of participation was labeled follow-up one, and the final year of participation was labeled follow-up two. The temperament measures, report of aggressive behaviors, and most of the parenting measures for the present study were obtained concurrently throughout the laboratory visits during either their follow-up one ( $n = 59$ ) or their follow-up two ( $n = 26$ ) years, depending on the enrollment status of the family in the parent project. Because the care neglect construct consisted of examiner observations of the home, the neglectful parenting construct included information provided during the initial year. Additionally, one of the measures used to create the maternal monitoring construct and the measure used to assess maternal personality were also collected during the family's initial year of participation.

## Measures

### The Children's Behavior Questionnaire (CBQ)

The CBQ (Rothbart, Ahadi, & Hershey, 1994; Rothbart et al., 2001) is a widely used parental-report measure of childhood temperament designed for ages 3-8. The CBQ consists of 195 items and is used to assess 15 subscales: Activity Level, Anger/Frustration, Approach/Positive Anticipation, Attentional Focusing, Discomfort, Falling Reactivity/Soothability, Fear, High Intensity Pleasure, Impulsivity, Inhibitory Control, Low Intensity Pleasure, Perceptual Sensitivity, Sadness, Shyness, and Smiling and Laughter. To accommodate the age range of the given study, a modified version of the CBQ was used. Items from the Early Adolescent Temperament Questionnaire—Revised, were included and scales not consistent with both questionnaires were removed (e.g., Discomfort items, Soothability items, and Perceptual Sensitivity items were removed since they do not appear in the EATQ-R). The modified version consisted of 140 items. Parents were asked to rate, on a scale from 1 = extremely untrue to 7=extremely true, how well each statement described their child. In the event that the parent had not observed the child in a particular situation, the CBQ also allowed parents to select a “not applicable” response. To create a subscale score, the items that loaded on each scale were summed, after reverse scoring the appropriate items, and divided by the total number of items that are rated. Omitted items and those marked not applicable were not included in the sum. The scale scores were then combined to create temperament factor scores. For the present study, Anger, Fear, and Sadness were averaged to create Negative Affectivity ( $M = 4.19$ ,  $SD = .69$ , range 2.77 to 5.69). Attention Focusing, Inhibitory Control, and Low-intensity Pleasure were averaged to create the Effortful

Control factor ( $M = 4.85$ ,  $SD = .74$ , range 2.19 to 6.58). The Surgency factor was created using Activity Level, High-intensity Pleasure, Impulsivity, and reverse-scored Shyness ( $M = 4.77$ ,  $SD = .63$ , range 3.27 to 6.52). Studies that have examined the factor structure of the CBQ have consistently found evidence for the 3 broad factors of temperament (Ahadi, Rothbart, & Ye, 1993; Kochanska, DeVet, Goldman, Murray, & Putnam, 1994; Rothbart et al., 2001). Coefficient alphas for the scales used in the present study were: Activity Level = .71, Anger = .86, Attention Focusing = .84, Fear = .81, High-intensity Pleasure = .81, Impulsivity = .68, Inhibitory Control = .85, Low-intensity Pleasure = .72, Sadness = .61, and Shyness = .87. Coefficient alphas for the respective factor scores were: Negative Affect = .68, Effortful Control = .77, and Surgency = .71.

#### Child Negative Affectivity Laboratory Tasks

To assess negative affectivity via observational methods, a modified version of the “Locked Box” task was used in the present study. The Locked Box task was originally part of the Laboratory Assessment of Temperament (Lab-Tab; Goldsmith, Reilly, Lemery, Longley, & Prescott, 1993), but has been modified by Kochanska and colleagues (e.g., Kochanska, 2001; Kochanska, Aksan, & Joy, 2007; Kochanska, Aksan, Penney, & Doobay, 2007) and was slightly modified to fit the age range of the current study. During this task, the child was asked to select 1 of 3 attractive but commercially unpopular games that was then locked in a clear Plexiglas box. Once the child selected the game, he/she was taken into the room and the experimenter excused herself while leaving the keys with the child. Before leaving the room, the experimenter asked the child to unlock the box so they can play the game when the experimenter returns shortly. However, the keys given to the child did not unlock the box. After 4 minutes, the

experimenter returned apologizing for giving the child the wrong keys and opened the box to play the game with the child.

To further assess for anger/frustration and sadness, the child was also given the Impossible Puzzle task. During this task, the child was asked to complete two puzzles in order to win a small prize (which was shown to the child). Using a similar procedure to one used by Dweck and colleagues, one puzzle was solvable and the other was unsolvable, because it had been altered by substituting some of the pieces with pieces from a similar puzzle (Burhans & Dweck, 1995; Smiley & Dweck, 1994). The experimenter presented the child with a simple animal character puzzle and asked the child to complete the puzzle as fast as they could. Once the child completed the first puzzle, the experimenter offered praise and then presented the child with an unsolvable puzzle (a Tangles puzzle with altered parts). The child was told to solve the puzzle within the 3-minute time limit. Once the time limit was up, the child was told “Time is up. Nice try but you did not quite finish the puzzle” and the experimenter left the room with the puzzles and the prize. After a minute, the experimenter returned and said “I’m sorry, but I gave you a puzzle that had some wrong pieces. I know you could have done the puzzle with the right pieces so here is a prize.”

#### Coding of Negative Affectivity Tasks.

The coding of child negative affectivity tasks was based on a coding system by Kochanska and colleagues (e.g., Kochanska, 2001; Kochanska, Aksan, Penney, et al., 2007). Throughout the negative affectivity tasks, for every 5-second segment, emotional expressions of anger/frustration and sadness, expressed with facial, bodily, or vocal cues were coded. The latencies to the first expression of anger and sadness were coded as well

(range from 0-240 seconds). Peak intensity of expression, ranging from 0 (the expression did not occur) to 3 (moderate and sustained expressions or sustained and strong expressions), were also coded. Negative affectivity was coded when the child engaged in behaviors such as crying, pouting, whining, throwing objects, hitting objects, and other tantrum behaviors, distinguishing between sadness and anger/frustration (e.g., sadness: pouting, slumped body and for anger: threatening looks to the experimenter, protests).

Based on the coding of the negative affectivity tasks, the tasks did not appear to tap into sadness as it was rarely coded (2 children displayed expressions of sadness). Therefore, the composite score only included coded anger/frustration scores. Peak intensity scores for each minute were summed and averaged for both the Locked Box task ( $M = 10.64$ ,  $SD = 2.06$ ,  $n = 64$ ) and the Impossible Puzzle task ( $M = 7.43$ ,  $SD = 3.05$ ,  $n = 67$ ) and then standardized. Latency to anger/frustration was reverse scored for both the Locked Box task ( $M = 229.40$ ,  $SD = 14.02$ ,  $n = 67$ ) and the Impossible Puzzle task ( $M = 217.26$ ,  $SD = 19.27$ ,  $n = 68$ ) and standardized. Finally, discrete expressions of anger/frustration were also averaged for both the Locked Box task ( $M = 35.76$ ,  $SD = 10.39$ ,  $n = 68$ ) and the Impossible Puzzle task ( $M = 26.56$ ,  $SD = 15.03$ ,  $n = 71$ ) and standardized.

### Behavioral Tasks of Effortful Control

For effortful control, the children completed two tasks that have been linked to effortful control: the Stroop test and the “Go/No-Go” task (Rothbart, 2007). The standard Stroop test (Stroop, 1935) consists of a control task and an interference task and has been used to assess interference control in children and was administered in a paper and pencil format (Boucugnani & Jones, 1989; Bush, Frazier, Rauch, Seidman, Whalen,

Jenike et al., 1999; Carter, Krener, Chaderjian, Northcutt, & Wolfe, 1995; Das, Snyder, & Mishra, 1992). The control task asks children to say the color of the printed X's (e.g., XXXX in blue, red, or green ink) aloud as fast as they can, while being timed. For the timed interference task, the child must say the ink color of the printed word while ignoring the word itself (e.g., the word "blue" is printed in red ink, and the child must say red). To perform the task successfully, the interference task requires the inhibition of the prepotent—or more automatic—response of reading the word (Lansbergen, Kenemans, & van Engeland, 2007). The classical method of calculating the interference (I) score, is by obtaining the time difference between the color (C) and color-word (CW) scores (i.e.,  $I = C - CW$ ; Lansbergen et al, 2007) and converting it to a T-score was used in the present study ( $M = 55$ ,  $SD = 6.96$ ,  $n = 57$ ). Children between the ages of 4-6 and for children 7 and up that had difficulty reading, the Day-Night Stroop task was administered because it eliminates the reading component. For this task, the children were presented with a PowerPoint slide show that displayed a sun or a moon. The children were asked to say night when presented with a sun and say day when presented with a moon. The Day-Night Stroop task has been used with children ages 3 ½ to 7 years of age (Gerstadt, Hong, & Diamond, 1994). Based on procedures from Wolfe and Bell (2007), the task began with a learning trial during which the child received feedback, and then 16 trials (8 sun and 8 moon images) were presented in random order. Similar to Kochanska and colleagues (e.g., Kochanska et al., 2000), when a child correctly responded, they scored a 1, when the child self-corrected they scored a 2, and when the child responded incorrectly they scored a 3. A percentage of correct scores, which did not include self-corrected responses, was created (range 0-100%;  $M = 78\%$ ,  $SD = 30.7$ ,  $n = 25$ ).

A simplified, “Go/No-Go” task was used in the present study. The “Go/No-Go” task has also been shown to be a marker of inhibitory control (e.g., Suskauer, Simmonds, Fotedar, Blankner, Pekar, Denckla, et al., 2008). During this task, the child was asked to press the button when a green spaceship appeared but not when a red spaceship appeared on the computer monitor. In order to establish the green spaceship as the prepotent response, it appeared more often than the red spaceship (at a ratio of 3:1; Suskauer et al., 2008). Errors, or false-alarms, on this task are indicative of poor inhibitory control ( $M = 23.79$ ,  $SD = 11.27$ ,  $n = 80$ ; Suskauer et al., 2008).

### Measures of Parenting, Child Temperament, and Child Aggression Constructs

#### Harsh Punitive Discipline Construct

The harsh/punitive discipline construct was created using scores from four different measures, parental report of discipline strategies, the Video Analog Parenting Task (VAPT; Knutson & Zaidi, 1989), as well as child report of spanking. The first measure of harsh punitive discipline was from the mother’s interview report of punishment of her child’s indirect and direct aggressive behaviors. This structured interview was derived from the Direct and Indirect Aggression Scale (DIAS; Björkqvist, Lagerspetz, & Österman, 1992), with permission of the authors. The DIAS consists of 24 items: 12 items on the Indirect Aggression Scale (e.g., exclude child from the peer group, gossip about the other child), 7 Physical Aggression items (e.g., kicking, hitting, and taking things from the other child), and 5 Verbal Aggression items (e.g., yelling/arguing with the other child, name calling). Each item is rated for frequency of occurrence on a 5-point Likert scale (0 = never, 1 = rarely, 2 = sometimes, 3 = almost always, and 4 =



always). After rating the frequency of the specific aggressive acts, the mother is asked: “Can you describe the last time your child did [the aggressive act], please include when it happened, who was involved, and how you responded to your child.” Responses are then categorized into: 1) positive reinforcement (e.g., rewarded or praised him/her), 2) punitive punishment (e.g., spanked him/her or yelled at him/her), 3) restrictive discipline (e.g., timeout, privilege restriction), 4) verbal reprimand (e.g., suggested a different way to behave, lecturing discipline), 5) no response to behavior/could not imagine child doing the behavior, and 6) other (e.g., seek professional help). For the purposes of this study, only the punitive discipline category was used. A total punitive discipline score was computed by creating a frequency count of the amount of times a mother used harsh/punitive disciplinary action, with higher scores indicating higher punitive discipline ( $M = .40$ ,  $SD = 1.04$ ). Examination of the distribution of the punitive proportion score indicated that the distribution was positively skewed; therefore, a logarithmic transformation was used to normalize the distribution ( $\log(x+.5)$ ).

Seven questions from a parent interview conducted during the first session of the family’s respective follow-up year were also used. These questions asked about injuries that resulted from parental use of discipline (e.g., “bruises after being disciplined, red mark that lasted for a few hours”), spanking (e.g., “have you spanked your child”) and other harsh forms of discipline (e.g., “washing the child’s mouth out with soap, restraining him/her”). Since these questions were answered either yes or no, no was coded as 1 and yes was coded as 2, and then summed to create a punitive discipline score ( $M = 1.27$ ,  $SD = 1.21$ ).

The third measure of the Harsh Discipline construct was the VAPT, which consists of 9 video episodes with 1 to 6 sequential scenes. To give the impression that the viewer is in the scene with the child, actors ages 4-9 were filmed using point-of-view camera work. The children engaged in a range of behaviors that could occasion discipline, including annoying behaviors, rule-violations, destructive behaviors, and dangerous activities. The mother was instructed to pretend to be the depicted child's caregiver. After each scene, mothers answered a series of questions pertaining to the appropriateness of the child behavior and how she would respond to the behavior of the depicted child if she were to discipline the child in each scene of each episode (e.g., time-out, not mind, yell, spank, slap, hit child with an object). For the purposes of this study, only the questions assessing parental disciplinary responses to the child's behavior were used. Specifically, the punitive/harsh discipline responses (e.g., yell, spank, slap, hit with object) were summed across scenes to generate a total score ( $M = 1.13$ ,  $SD = 1.21$ ). The distribution indicated that the measure was positively skewed; therefore, it was log transformed using an  $\ln(X + .5)$  transformation. As a fourth measure, and to create a multi-informant construct, children's responses to the question "have you ever been spanked" was used, with yes coded as 1 and no coded as 2 and was reversed scored so higher scores indicated corporal discipline ( $M = 1.56$ ,  $SD = .50$ ).

#### Maternal Monitoring Construct

To assess mothers' knowledge of their child's behavior, both mothers and children completed the Children's Experience and Excitement Scale (CEES: Selner, 1992; Selner & Knutson, 1990). During their initial visit to the laboratory, children were interviewed about their engagement in 44 activities depicted in a slideshow presented on

a computer screen. Each scene depicted child behaviors which ranged from age-appropriate acts (e.g., sleeping, eating, playing with toys), dangerous behaviors (e.g., child loading a handgun), rude/destructive behaviors (e.g., destroying audiotapes), and age-inappropriate behaviors (e.g., children kissing, child perusing an “adult” magazine). In an attempt to avoid inadvertently encouraging subject children from engaging in some of the behaviors depicted in the slideshow, prior to its administration, the children were informed that the children in the slides were paid actors. Children were asked if they had ever engaged in the behavior, and if not, had they ever had the opportunity to do so. During the same session, mothers—who are unaware of their child’s responses—were asked to complete the CEES in a self-report format. Concordance scores between parent and child were computed for both the child’s experiences and the child’s opportunities (mother-child affirmative matched pairs and mother-child negative pairs were added across all slides;  $M = 33.28$ ,  $SD = 3.4$ ), which provided an index of supervision.

Maternal involvement and monitoring was also assessed using the Children’s Reinforcement Survey Schedule (RSS; Clement & Richard, 1976). The RSS that was administered to both the mother and the child during the year they received the measures unique to this study was used. Children were interviewed about people they spend time with each week, places they regularly go, their favorite foods/drinks, items they regularly use (e.g., toys, books), and activities in which they regularly engage (e.g., sports, reading, playing outside). Parents were also asked the same questions in a self-report format. Based on the work of Hall (1986), a score of parental involvement was calculated by deriving an agreement score for each section and a total agreement score. For the purposes of this study, only the total agreement for occurrence total was used, which

indicates how well mother and child matched on their responses to the measure on all of the items assessed ( $M = .38$ ,  $SD = .08$ ).

### Deficient Parenting Construct

A Deficient Parenting construct, consisting of inconsistent discipline and care neglect was also created. Mothers were asked ten questions assessing their ability to regulate their child's behavior (e.g., "How often do you have to threaten child with a consequence so that he/she will do something," "If you warn child that she will be disciplined, how often do you actually discipline him/her?"), and comprised the inconsistent discipline measure. A rating scale from 1 = never or almost never to 5 = always or almost always was used. As appropriate, some questions (e.g., "How often did you actually discipline if child did not stop?" "How often did your child know how you would react?") were reversed scored and lower scores indicated higher inconsistent discipline.

The Care Neglect Index comprised of maternal report combined with objective observer ratings of the environmental and social risks of the household, which were identified during an in-home interview. The structured interview consisted of questions regarding the circumstances of the child's life, family background, and living conditions (e.g., dental and medical history, amount of supervision provided, and hygiene). This structured interview was based, in part, on the modification of the Home Observation for Measurement of the Environment (HOME: Caldwell & Bradley, 1978) developed for use in the Project on Human Development in Chicago Neighborhoods (PHDCN; Leventhal, Selner- O'Hagan, Brooks-Gunn, Bingenheimer & Earls, 2004) and, in part, on the recommendations of the Research Sub-Committee of the Interagency Task Force on

Child Abuse and Neglect (Sternberg, Knutson, Lamb, Baradaran, Nolan, & Flanzer, 2004). The interview included questions related to injury prevention derived from research by Peterson, Ewigman, and Kivlahan (1993) and a home safety inventory (Tymchuk, Lang, Dolyniuk, Berney-Ficklin & Spitz, 1999). Because the interview was conducted in the home of the participants, it was possible to obtain direct information regarding evidence of neglect manifested in the condition of the home, including sleeping arrangements, cleanliness, plumbing, personal hygiene of family members, and any health or safety hazards threatening the children in the household identified by the interviewer. Upon completion of the home visit, the interviewer also completed a checklist of the child's physical indoor and outdoor environment noting environmental hazards and the conditions of the community (e.g., broken glass, drug paraphernalia, conditions of the surrounding homes, trash, animal feces, and traffic volume of the street). A total of 54 items derived from both the in-home interview and the observer ratings were summed, with higher scores indicating higher levels of care/environmental neglect ( $M = 8.58, SD = 3.97$ ). Prior studies using a similarly selected sample have found this index to be a robust measure of care neglect (c.f., Knutson et al., 2005).

#### Children's Negative Affectivity Construct

To assess negative affectivity, the mother's report of their child's negative affectivity on the modified CBQ was used. The child's score on the Anger, Fear, and Sadness scales were summed and averaged to create a score of negative affectivity ( $M = 4.19, SD = .69, \text{range: } 2.77 \text{ to } 5.69$ ). The total anger/frustration scores from the Locked Box task and the Impossible Puzzle task were also included as measures of this construct.

### Children's Surgency Score

A Surgency factor from the CBQ was created by averaging the scores of the following scales: Activity Level, High-Intensity Pleasure, Impulsivity, and reverse scored Shyness ( $M = 4.77$ ,  $SD = .63$ , range: 3.27 to 6.52).

### Children's Effortful Control Construct

An Effortful Control factor from the CBQ was created by averaging the scores of the following scales: Attention Focusing, Inhibitory Control, and Low-Intensity Pleasure ( $M = 4.85$ ,  $SD = .74$ , range: 2.19 to 6.58). The interference score from both the Stroop and the child's false alarm score from the Go/No-Go task were also included in measures of this construct.

### Children's Aggressive Behaviors

Children's report of their own aggressive behaviors was assessed with the DIAS-Child Interview. The DIAS is a structured interview based on the work of Björkqvist et al. (1992) that was designed to assess the child's use of direct—physical and verbal aggression—and indirect aggression. Children were asked if they had engaged in each of the 24 aggressive acts included in the original DIAS. The scoring for each item was set to be comparable to the DIAS parent interview. Cronbach's alpha for the Physical, Verbal, and Indirect Aggression subscales of the DIAS-Interview administered to a comparable child sample in a previous study (Valles & Knutson, 2008) were reported as .78, .76 and .81 respectively, and .89 for the Total Aggression Scale. For the purposes of the current study, however, only the Direct Aggression Scales were used.

Another aggression measure used was the child's responses and interpretations to 4 ambiguous vignettes (e.g., a child hits the other child on the back with a ball during a

game of catch). The vignettes were read to the child and the child was asked how they would respond if the situation had occurred (a measure of hostile actions, such as retaliate, strike the other child) and why they think the other child engaged in the behavior (i.e., non-hostile and hostile attributions). Similar to Knutson et al. (2005), a total score was created by summing together responses that indicated retaliation or hostile intent (the range is from 0-8;  $M = 1.6$ ,  $SD = 1.4$ ).

### Measures of the Covariate Constructs

#### Social Status Construct

During the in-home interview, parents were asked what their highest level of education was, as well as their current occupation. Education level was then classified into five categories: 1 (never reached high school; 6%), 2 (high school diploma or GED; 29%), 3 (some college/Associate's degree; 51%), 4 (Bachelor's degree; 13%) and 5 (graduate or professional education; 1%). Occupations were also classified into five categories: 1 (unemployed/homemaker/student; 43%), 2 (unskilled, e.g., waitress; 13%), 3 (semi-skilled, e.g., secretary; 24%), 4 (skilled, e.g., plumber; 13%), and 5 (professional, e.g., business owner; 7%). Changes in either education or occupation were recorded during each follow-up; therefore, the education and occupation level of the follow-up year in which the family received the temperament measures was used in this study. The third measure was a scale from the Home Environment Questionnaire (HEQ; Laing & Sines, 1982; Sines, Clark, & Lauer, 1984). The HEQ is a true-false self-report measure used to obtain objective information about the child's home, neighborhood, and family environments. For the purposes of this study, only the Social Status Scale T-score was

used. This scale specifically assesses family involvement in community affairs and parents support for academic achievement ( $M = 54.48$ ,  $SD = 9.14$ ).

### Maternal Personality Construct

During the initial year, mothers were asked to complete the Multidimensional Personality Questionnaire—Brief Form (Patrick, Curtin, & Tellegen, 2002). The MPQ-BF is a 155-item shortened version of the MPQ (Tellegen, 1982; in press) and is used to assess the “Big Three” personality factors of Negative Emotionality (NEM), Positive Emotionality (PEM), and Constraint (CON), by assessing 11 lower-order/primary traits (i.e., wellbeing, social potency, achievement, social closeness, stress reaction, alienation, aggression, control, harm avoidance, traditionalism, and absorption). The broad higher-order factors of NEM ( $M = 36.65$ ,  $SD = 15.56$ ), PEM ( $M = 70.9$ ,  $SD = 13.37$ ), and CON ( $M = 87.18$ ,  $SD = 10.23$ ) were standardized and used as measures of maternal personality. The MPQ-BF has been reported to have adequate psychometric properties and yields a similar factor structure to its predecessor the MPQ (Patrick et al., 2002).



## CHAPTER VII

### RESULTS

#### Preliminary Analyses

Since the participants were from both IA and WI sites, univariate ANOVAs were conducted to determine if significant differences existed between sites. Results indicated that mothers in IA reported higher levels of child Negative Affectivity compared to WI mothers ( $F[1, 83] = 5.4, p = .02$ ). It is not clear whether this difference is meaningful or a Type I error. Given the sample sizes, it was not possible to conduct separate analyses for the WI and IA samples. Children from the IA site ( $M = 7.4$ ) were also somewhat older compared to the WI site ( $M = 6.4; F [1, 83] = 8.05, p = .006$ ). No other significant differences were found between sites; therefore, the sites were analyzed together.

Correlations among variables were examined to determine if the variables could be aggregated to create the constructs of interest. Notably, the two regression scores created using principal components analysis (PCA), for the anger/frustration laboratory tasks were not significantly correlated ( $r = .09, p \geq .10$ ), which precluded aggregating the scores to create a single anger/frustration score. The two tasks also failed to correlate with other key variables and were subsequently dropped from the analyses. Failure to correlate could have been due to the small sample size ( $n = 60$  for Locked Box task and  $n = 53$  for the Impossible Puzzle task) and/or to the alterations made to the tasks (i.e., increased length of tasks, modified tasks).

For the effortful control construct, the scores between the standard Stroop and the Day-Night Stroop could not be aggregated due to the absence of a correlation between the measures, largely attributable to the lack of variance in the Day-Night Stroop task.

Therefore, only the Stroop Interference score was used as a behavioral measure of Effortful Control in subsequent analyses. Both the Stroop and the CBQ Effortful Control factor correlated .27 ( $p \leq .05$ ). The two scores were aggregated using principal component analysis (PCA). Results of the PCA indicated that both measures had a component score of .80 (Bartlett's Test of Sphericity:  $\chi^2 [1, n = 57] = 4.24, p = .04, KMO = .50$ ); therefore, the overall Effortful Control regression factor score produced by PCA was used.

The Go/No-go task did not correlate with Effortful Control but instead correlated with mother report of Surgency ( $r = .25, p \leq .05$ ), therefore, both were combined to create a Surgency construct. That the Go/No-go task correlated with Surgency is not surprising given that the Go/No-go task has also been linked to impulsivity which is a lower level trait of Surgency (Bezdjian, Baker, Lozano, & Raine, 2009). Therefore, a combined Surgency score was created using PCA, which created a regression factor score for the combined measures. The component scores for both CBQ Surgency and the Go/No-go task was .80 (Bartlett's Test of Sphericity:  $\chi^2 [1, n = 80] = 5.01, p = .03, KMO = .50$ ).

The DIAS aggression score and the child aggressive responses to the ambiguous vignettes were not significantly correlated ( $r = .07$ ); therefore, the scores could not be combined to create a single aggression factor. Given that the DIAS is a measure of aggressive behaviors as opposed to aggressive intent, the standardized DIAS direct aggression total score was used as the criterion. The HEQ SS scale did not correlate with mother's occupation ( $r = .04$ ) but mother's education and mother's occupation correlated .27 ( $p \leq .05$ ). Therefore, using the category score of the mother's report of education and

occupation, a combined regression factor score of social status was created using PCA (Bartlett's Test of Sphericity:  $\chi^2$  [1, n = 85] = 6.08, p = .01, KMO = .50).

The DIAS Punitive Discipline proportion score failed to correlate with other punitive discipline measures; therefore, it was dropped from the construct. Correlations among the other three measures ranged from .23 to .65. A PCA was used to create a combined regression factor score for the three remaining measures of punitive discipline. The component scores were .64, .88, and .81 for the child report of spankings, abusive discipline indicator, and VAPT respectively (Bartlett's Test of Sphericity:  $\chi^2$  [3, n = 82] = 48.67, p = .000, KMO = .60); therefore, the regression factor score created by PCA was used.

Both the RSS and the CEES were correlated .30 (p ≤ .001). Principal component analysis was conducted to create an aggregated score of maternal monitoring, using the concordance scores obtained from the CEES and the RSS. Results indicated that the RSS had a component score of .80 and the CEES had a component score of .81 (Bartlett's Test of Sphericity:  $\chi^2$  [1, n = 84] = 7.49, p = .006, KMO = .50).

The Care Neglect and Inconsistent Discipline measures correlated .23 (p ≤ .05). Principal component analysis was conducted to create a combined deficient parenting regression factor score and both measures had a component score of .78 (Bartlett's Test of Sphericity:  $\chi^2$  [1, n = 85] = 4.30, p = .04, KMO = .50).

Correlations among all of the covariates, predictors, and the children's aggression criterion are presented in Table 1. Regarding the child aggression criterion, child's age and the Harsh Discipline construct positively correlated with aggressive behaviors and the Effortful Control construct negatively correlated with the child's report of their

aggressive behaviors. Higher levels of maternal NEM were associated with higher levels of harsh parenting. Deficient parenting was negatively correlated with PEM and child effortful control, and positively correlated with maternal NEM and child negative affectivity. The child's effortful control was negatively correlated with age. Child negative affectivity was positively correlated with gender, with mother's reporting higher levels of negative affectivity for girls compared to boys. Child negative affectivity was also positively correlated with maternal NEM and deficient parenting. Surgency was only positively correlated with maternal PEM.

#### Testing Main and Interaction Effects of Parenting and Temperament on Aggressive Behaviors

Hierarchical regression analyses were used to examine both main and interaction effects of the predictor variables. All of the covariates (i.e., age, gender, SES, maternal personality) were entered at step 1, the respective parenting and temperament variables were entered at step 2, and the interaction effect was entered at step 3. The regression tables include Bs, SE of Bs, and  $\beta$ s for each predictor and  $R^2$  and  $F_{ch}$  for each step of the model.

The first regression analysis examined the relation between harsh/punitive discipline and child Negative Affectivity on aggressive behaviors. Since gender, maternal Positive Emotionality, and Constraint did not correlate with the predictor and/or the criterion variables, they were dropped from the analyses. Only the second step, which included both Harsh Discipline and child Negative Affectivity, significantly contributed to the variance of aggressive behaviors ( $r^2 = .19$ ). Results of the first regression are presented in Table 2. Results indicated that Negative Affectivity did not

have a main or interaction effect on aggression. Age had a significant effect on aggressive behaviors ( $\beta = .23$ ,  $p \leq .05$ ), with older children reporting higher use of aggressive behaviors compared to younger children. However, after holding the significant effect of age constant, Harsh/Punitive discipline had a strong main effect on child aggression ( $\beta = .36$ ,  $p \leq .01$ ), with higher levels of harsh discipline predicting higher levels of child reported aggressive behaviors.

The second regression analysis examined the relation between Deficient Parenting, Surgency, and Aggression (results are presented in Table 3). Gender, maternal Negative Emotionality, and maternal Constraint did not correlate with the criterion or other predictors so they were dropped from the analyses. Results indicated that neither the control variables nor the predictor variables had main or interactive effects on children's aggressive behaviors. Age was marginally significant, with older children reporting higher levels of aggressive behavior ( $\beta = .23$ ,  $p = .06$ ). The inclusion of the covariates in the first step marginally accounted for 9% of the variance of aggressive behaviors, but the constructs included in subsequent steps of the regression analyses were not statistically significant.

The final regression analysis examined the relation between poor Maternal Monitoring and child Effortful Control on child aggressive behaviors. Results are presented in Table 4. Gender, maternal NEM, and maternal CON were not correlated with the predictors or the criterion so they were dropped from the analysis. The first step, which included the covariates, significantly accounted for 22% of the variance of in aggressive behaviors ( $r^2 = .22$ ), while the constructs assessed in subsequent steps of the regression were not statistically significant. Age was significant during the first step ( $\beta =$

.30,  $p \leq .05$ ) but the effect was non-significant during the second and third step. Neither Maternal Monitoring nor the Effortful Control construct had significant effects on child reported aggression. Only Social Status had a significant main effect on children's aggressive behavior ( $\beta = .32$ ,  $p \leq .05$ ); however, it was not in the expected direction, with higher social status predicting higher levels of aggressive behaviors.

Testing Main and Interaction Effects of Parenting and  
Temperament on Aggressive Behaviors Using Path  
Analyses

Because the sample size fluctuated depending on the completed measures, to enhance power, path analyses were conducted to permit the use of full information maximum likelihood estimation (FIML). For all structural equation modeling, model fit was examined before interpreting model parameters. Specifically, the indices of model fit used were:  $\chi^2$  value with model  $df$  (non-significant at the  $p > .05$ ), the Tucker-Lewis Index (TLI; greater than .95), Incremental Fit Index (IFI; greater than .95), and the Root Mean Square Error of Approximation (RMSEA less than .06; Bollen, 1989; Steiger & Lind, 1980; Tucker & Lewis, 1973). Prior to conducting the path analyses, a missing values analysis for all of the variables of interest was conducted to establish that values were missing at random to ensure that FIML could be used without violating assumptions. Little's test of missingness indicated that the data were missing completely at random (MCAR),  $\chi^2 = 34.73_{(41)}$ ,  $p = .74$ , which allowed for the use of FIML. The variables used were based on those used in the regression analysis examining the same proposed hypotheses. Specifically, for hypothesis one, the covariates examined were age, Social Status and maternal Negative Emotionality, the predictors were

Harsh/Punitive Discipline and childhood Negative Affectivity, and the centered interaction term of Harsh Discipline and child Negative Affectivity. For hypothesis two, the covariates of age, Social Status, and maternal Positive Emotionality were used, and the predictors were Deficient Parenting, child Surgency, and the centered interaction term between Deficient Parenting and Child Surgency. For hypothesis three, the covariates examined were age, Social Status, and maternal Positive Emotionality, and the predictors were poor Maternal Monitoring, Effortful Control, and the centered interaction between Maternal Monitoring and Effortful Control.

The first path analysis examined the relation between Harsh/Punitive Discipline, childhood Negative Affectivity, the covariates (i.e., age, Social Status, and maternal Negative Emotionality), and the criterion aggressive behaviors (see Figure 1). Maternal NEM and child Negative Affectivity ( $r = .16, p = .05$ ), Punitive Discipline and the interaction variable ( $r = -.28, p \leq .001$ ) and child Negative Affectivity and the interaction variable ( $r = .08, p \leq .10$ ) were allowed to covary. Model fit indices indicated that the model was a good fit to the data ( $\chi^2 = 8.04 [12, n = 85], p = .78, TLI = 1.0, CFI = 1.0, IFI = 1.0, RMSEA = .00$ ). Consistent with the regression findings, the Harsh Punitive Discipline construct emerged as a significant predictor of child report of aggressive behaviors ( $\beta = .38, p \leq .001$ ), with higher punitive discipline associated with higher levels of aggressive behaviors. Age, a control variable, was also a significant predictor of aggressive behaviors, with older children reporting higher usage of aggressive behaviors compared to younger children ( $\beta = .24, p \leq .05$ ). All other paths, including child Negative Affectivity, were not statistically significant.

For the tested relation between Deficient Parenting, Surgency, and aggression, with the covariates of age, Social Status, and maternal Positive Emotionality, results indicated that the model had adequate fit to the data ( $\chi^2 = 12.32$  [12,  $n = 85$ ],  $p = .42$ , TLI = .93, CFI = .97, IFI = .99, RMSEA = .02; see Figure 2). Again, to ensure the model would be identified, maternal PEM and Deficient Parenting were allowed to covary ( $r = -.32$ ,  $p \leq .01$ ), as were PEM and child Surgency ( $r = .20$ ,  $p \leq .05$ ), and child Surgency with the interaction term ( $r = .20$ ,  $p \leq .10$ ). For this model, only age emerged as a significant predictor ( $\beta = .26$ ,  $p \leq .05$ ). That is, older children reported more aggressive behaviors compared to younger children in the present sample. Regarding the control variables, PEM was marginally significant ( $\beta = -.20$ ,  $p = .09$ ), with higher levels of maternal PEM predicting lower levels of childhood aggression. All other paths in the model, including Deficient Parenting and child Surgency, were not significantly different from zero.

The final path analysis examined the relation between the covariates age, Social Status, and maternal Positive Emotionality, the predictors of poor Maternal Monitoring and Effortful Control, and the criterion of child aggressive behaviors. To ensure that the model would be identified, age and child effortful control were allowed to covary in the model ( $r = -.94$ ,  $p \leq .001$ ). The fit indices indicated a good fit to the data ( $\chi^2 = 13.76$  [14,  $n = 85$ ,  $p = .47$ , TLI = 1.0, IFI = 1.0, CFI = 1.0, RMSEA = .00). However, none of the paths outlined in the model, including both Maternal Monitoring and child Effortful Control, were significantly different from zero (see Figure 3).



## Post-Hoc Analyses Using Maternal Report of Child

### Aggression

Given that some researchers have argued that using child report of outcomes could be problematic (De Los Reyes & Kazdin, 2005), the author wanted to examine the pattern of results using maternal report of aggressive behaviors. The data were not aggregated because mother and child report of aggressive behaviors were not significantly correlated. However, other studies have recommended that multisource data be examined separately (e.g., Tremblay, 2000) due to the insight that each informant provides. Therefore, the same hypothesized relations between harsh discipline, deficient parenting, and parental monitoring and child temperament examined using child report were examined using mother report of child aggressive behaviors. Notably, the testing of the hypothesized effect of Harsh/Punitive Discipline and child Negative Affectivity on aggressive behaviors relied on maternal report for mother's personality, child temperament, and for the criterion, thus it was a monosource test of the hypothesis. However, all other tested hypotheses used a multimethod multisource methodology.

### Testing Main and Interaction Effects of Parenting and Temperament on Maternal Report of Child Aggressive Behaviors

Hierarchical regression analyses were used to examine both main and interaction effects of the predictor variables. Similar to the child report of aggression analyses, all of the covariates (i.e., age, gender, SES, maternal personality) were entered at step 1, the respective parenting and temperament variables were entered at step 2, and the

interaction term was entered at step 3. The regression tables include Bs, SE of Bs, and  $\beta$ s for each predictor and  $R^2$  and  $F_{ch}$  for each step of the model.

For the regression analysis examining the relation between Harsh/Punitive Discipline and child Negative Affectivity on maternal report of their child's aggressive behaviors, only maternal Negative Emotionality was a significant predictor of aggressive behaviors ( $\beta = .27, p \leq .05$ ). Specifically, higher levels of maternal report of their own negative emotionality predicted higher levels of maternal reports of child aggressive behaviors (see Table 5). Punitive parenting and child Negative Affectivity were not significant predictors and neither was the interaction term. The inclusion of the covariates significantly accounted for 9% of the variance in mother reports of child aggressive behaviors ( $r^2 = .09$ ), while the predictors included in the subsequent steps did not significantly contribute to the variance in aggression.

The second regression analysis examined the relation between Deficient Parenting, child Surgency, and aggression (see Table 6). Results indicated that Deficient Parenting predicted maternal report of aggressive behaviors ( $\beta = .31, p \leq .05$ ) but no other predictors were statistically significant. Specifically, using maternal report of aggressive behaviors, high levels of deficient parenting predicted high levels of child aggression. Step 2, which included the deficient parenting construct and the child Surgency factor significantly accounted for 9% of the variance in maternal report of child aggression ( $r^2 = .09, p \leq .05$ ).

The final regression analysis examined the relation between Maternal Monitoring and Effortful Control on maternal reports of child aggressive behaviors. Results are presented in Table 7. For this model, only Effortful Control had a main effect on

maternal report of child aggressive behaviors ( $\beta = -.34, p \leq .05$ ). Specifically, higher levels of effortful control predicted lower levels of aggressive behaviors. Notably, the variables included at each step did not significantly contribute to the variance in aggressive behaviors, as the change in  $r^2$  was not significant at each step.

### Testing Main and Interaction Effects of Parenting and Temperament on Maternal Report of Aggressive Behaviors Using Path Analyses

Again, to make use of full information maximum likelihood, the regression analyses were repeated using path analysis as they were with the child report of aggression. The same variables tested in the previous regression analyses were tested in a series of path analyses. The first hypothesis examined the relation between Harsh/Punitive Discipline, child Negative Affectivity, and the interaction term on maternal report of child aggressive behaviors, controlling for child age, Social Status and maternal Negative Emotionality. For the second hypothesis, the covariates of age, Social Status, and maternal Positive Emotionality were used, and the predictors were Deficient Parenting, child Surgency, and the centered interaction term between Deficient Parenting and Child Surgency. The third hypothesis examined the relation between poor Maternal Monitoring, child effortful control and the centered interaction term, on child aggressive behaviors, with the covariates age, Social Status, and maternal Positive Emotionality.

For the first hypothesis, testing the relation between Punitive Discipline and child Negative Affectivity on maternal reports of the child's aggressive behaviors, the model showed good fit to the data ( $\chi^2 = 8.36 [12, n = 85], p = .76, TLI = 1.0, CFI = 1.0, IFI = 1.10, RMSEA = .00$ ; see Figure 4). To ensure the model would be identified, maternal

NEM was allowed to covary with child Negative Affectivity ( $r = .16, p \leq .05$ ), and both Punitive Discipline and child Negative Affectivity were allowed to covary with the interaction term ( $r = -.28, p \leq .001$  and  $r = .08, p \geq .10$ , respectively). Only maternal NEM had a significant main effect on maternal report of aggressive behaviors ( $\beta = .28, p \leq .01$ ). No other variables were significantly different from zero, including both Punitive Discipline and child Negative Affectivity.

For the relation between Deficient Parenting and child Surgency on maternal report of aggressive behaviors, the model showed adequate fit to the data ( $\chi^2 = 12.31 [12, n = 85], p = .42, TLI = .94, CFI = .97, IFI = .99, RMSEA = .02$ ; see Figure 5). Similar to the model based on the child report data, PEM and deficient parenting were allowed to covary ( $r = -.32, p \leq .01$ ), as were PEM and child Surgency ( $r = .20, p \leq .05$ ) and child Surgency with the interaction term ( $r = .20, p \leq .10$ ). Consistent with the regression analyses, only deficient parenting had a significant main effect on mother report of aggressive behaviors ( $\beta = .36, p \leq .01$ ), with higher levels of deficient parenting predicting higher levels of child aggressive behaviors. The paths for the covariates, which included age, social status, and PEM, the path for child Surgency, and the path for the interaction term were not significantly different from zero.

The final model (see Figure 6), examined the relation between Maternal Monitoring and child Effortful Control on maternal report of aggressive behaviors. Age and child Effortful Control were allowed to covary ( $r = -.63, p \leq .01$ ). The model showed adequate fit to the data ( $\chi^2 = 14.52 [12, n = 85], p = .41, TLI = .90, CFI = .95, IFI = .98, RMSEA = .02$ ). Similar to the regression analyses, only the path from Effortful Control to aggressive behaviors was statistically significant ( $\beta = -.34, p \leq .05$ ), with higher levels

of child Effortful Control predicting lower levels of child aggressive behaviors. All other paths were not significantly different from zero.

In summary, using child report of aggressive behaviors, age, Social Status, and Harsh/Punitive discipline were directly related to higher levels of aggressive behaviors. Also, maternal Positive Emotionality marginally predicted lower levels of aggressive behaviors in children. However, using maternal report of aggressive behaviors, maternal Negative Emotionality and Deficient Parenting were directly related to higher levels of aggressive behaviors, while Effortful Control had an inverse relation with aggressive behaviors. In this disadvantaged sample, none of the analyses conducted provided evidence of temperament as a moderator between parenting and aggressive behaviors.

Table 1: Correlations Among Covariates, Predictors, and Child Report of Aggression

Variables	1	2	3	4	5	6	7	8	9	10	11	12	13
1. Age	---												
2. Gender	.07	---											
3. SS	.13	.06	---										
4. PEM	-.03	.09	.09	---									
5. NEM	.07	.06	-.01	-.01	---								
6. CON	.00	-.03	.02	-.03	<b>-.25*</b>	---							
7. Harsh	-.08	-.05	-.01	-.01	-.10	-.02	---						
8. Def Par	.09	.12	-.13	<b>-.32**</b>	<b>.22*</b>	-.19	.04	---					
9. Monitor	.17	-.12	.02	.13	<b>-.29**</b>	-.04	-.09	-.16	---				
10. NA	.05	<b>.36**</b>	-.06	-.11	<b>.24*</b>	-.07	-.15	<b>.35**</b>	-.13	---			
11. Surge	-.14	-.17	-.06	<b>.23*</b>	-.04	-.12	.03	-.01	.14	-.17	---		
12. EC	<b>-.53**</b>	.20	-.09	.19	-.11	.06	-.17	<b>-.28*</b>	.12	-.16	-.11	---	
13. Aggr	<b>.25*</b>	.04	.15	-.15	-.06	.03	<b>.35**</b>	-.05	.06	-.01	-.03	<b>-.32**</b>	---

Note: SS = Mother's Social Status, PEM = Maternal Positive Emotionality, NEM = Maternal Negative Emotionality, CON = Maternal Constraint, Harsh = Harsh/Punitive Discipline Factor, Def Par = Deficient Parenting Factor, Monitor = Maternal Monitoring Factor, NA = Child's Negative Affectivity Score, Surge = Child's Surgency Factor Score, EC = Child's Effortful Control Factor Score, Aggr = Child's Direct Aggression Score.

Significant correlations have been emboldened.

\*\*  $p < .01$

\*  $p < .05$

Table 2: Children's Negative Affectivity as a Moderator of Harsh Discipline and Children's Report of Aggressive Behaviors.

Predictor(s) entered	Step 1			Step 2			Step 3		
	$\beta$	<i>B</i>	<i>SE B</i>	$\beta$	<i>B</i>	<i>SE B</i>	$\beta$	<i>B</i>	<i>SE B</i>
Step 1 (covariates)									
Child Age	.23*	.16	.08	.23*	.16	.08	.23*	.16	.08
Social Status	.07	.07	.12	.10	.10	.11	.10	.10	.12
MPQ NEM	-.06	-.06	.11	-.04	-.04	.11	-.04	-.04	.11
Step 2									
Harsh Discipline				.35**	.36	.11	.36**	.37	.12
NA Score				.04	.06	.16	.04	.05	.16
Step 3									
PunXNA							.02	.02	.16

Note. *B* and  $\beta$  are for the final equations, with all predictors entered. Child age, maternal social status, and mother's Negative Emotionality was entered in Step 1, harsh discipline and child's negative affectivity was entered in Step 2, and the interaction between harsh discipline and negative affectivity was entered in Step 3.

\* $p < .05$ , \*\*  $p < .01$ .

After Step 1,  $R^2 = .07$ ,  $F_{ch}(3, 69) = 1.61$ ; after Step 2,  $R^2 = .19$ ,  $F_{ch}(2, 67) = 5.07^{**}$ ; after Step 3,  $R^2 = .19$ ,  $F_{ch}(1, 66) = .02$ .

Table 3: Children's Surgency as a Moderator of Deficient Parenting and Children's Report of Aggressive Behaviors.

Predictor(s) entered	Step 1			Step 2			Step 3		
	$\beta$	<i>B</i>	<i>SE B</i>	$\beta$	<i>B</i>	<i>SE B</i>	$\beta$	<i>B</i>	<i>SE B</i>
Step 1 (covariates)									
Child Age	.21†	.15	.08	.23†	.16	.09	.23†	.17	.09
Social Status	.14	.14	.12	.13	.13	.12	.13	.13	.12
MPQ PEM	-.15	-.01	.01	-.20	-.02	.01	-.21	-.02	.01
Step 2									
Deficient Parenting				-.10	-.10	.14	-.10	-.10	.14
Surgency Factor				.07	.07	.12	.07	.06	.13
Step 3									
DefXSurgency							.03	.03	.12

Note. *B* and  $\beta$  are for the final equations, with all predictors entered. Child age, maternal social status, and mother's Positive Emotionality was entered in Step 1, deficient parenting and child's Surgency was entered in Step 2, and the interaction between deficient parenting and child Surgency was entered in Step 3.

† $p < .10$ , \* $p < .05$ , \*\*  $p < .01$ .

After Step 1,  $R^2 = .09$ ,  $F_{ch}(3, 68) = 2.25†$ ; after Step 2,  $R^2 = .10$ ,  $F_{ch}(2, 66) = .40$ ; after Step 3,  $R^2 = .10$ ,  $F_{ch}(1, 65) = .05$ .



Table 4: Children's Effortful Control as a Moderator of Maternal Monitoring and Children's Report of Aggressive Behaviors.

Predictor(s) entered	Step 1			Step 2			Step 3		
	$\beta$	<i>B</i>	<i>SE B</i>	$\beta$	<i>B</i>	<i>SE B</i>	$\beta$	<i>B</i>	<i>SE B</i>
Step 1 (covariates)									
Child Age	.30*	.26	.10	.23	.19	.13	.23	.19	.12
Social Status	.31*	.26	.14	.29*	.34	.15	.32*	.37	.14
MPQ PEM	-.20	-.02	.01	-.18	-.01	.01	-.20	-.02	.01
Step 2									
Parental Monitor				.02	.02	.12	.01	.01	.12
EC Factor Score				-.14	-.14	.15	-.15	-.15	.15
Step 3									
MonXEC							.18	.18	.12

Note. *B* and  $\beta$  are for the final equations, with all predictors entered. Child age, maternal social status, and mother's Positive Emotionality was entered in Step 1, parental supervision and child's effortful control factor was entered in Step 2, and the interaction between maternal monitoring and effortful control was entered in Step 3.

\* $p < .05$ , \*\*  $p < .01$ .

After Step 1,  $R^2 = .22$ ,  $F_{ch}(3, 52) = 4.89^{**}$ ; after Step 2,  $R^2 = .23$ ,  $F_{ch}(2, 50) = .40$ ; after Step 3,  $R^2 = .26$ ,  $F_{ch}(1, 49) = 2.05$ .

Table 5: Children's Negative Affectivity as a Moderator of Harsh Punitive Discipline and Maternal Report of Aggressive Behaviors.

Predictor(s) entered	Step 1			Step 2			Step 3		
	$\beta$	<i>B</i>	<i>SE B</i>	$\beta$	<i>B</i>	<i>SE B</i>	$\beta$	<i>B</i>	<i>SE B</i>
Step 1 (covariates)									
Child Age	.06	.04	.07	.06	.04	.07	.07	.04	.07
Social Status	.02	.02	.11	.03	.03	.11	.06	.06	.11
MPQ NEM	.29**	.29	.11	.27*	.27	.11	.27*	.27	.11
Step 2									
Harsh Discipline				.07	.07	.11	.14	.14	.12
NA Score				.10	.14	.17	.07	.10	.17
Step 3									
PunXNA							.18	.23	.17

Note. *B* and  $\beta$  are for the final equations, with all predictors entered. Child age, maternal social status, and mother's Positive Emotionality was entered in Step 1, parental supervision and child's effortful control factor was entered in Step 2, and the interaction between parental supervision and effortful control was entered in Step 3.

\* $p < .05$ , \*\*  $p < .01$ .

After Step 1,  $R^2 = .09$ ,  $F_{ch}(3, 76) = 2.50^\dagger$ ; after Step 2,  $R^2 = .10$ ,  $F_{ch}(2, 74) = .52$ ; after Step 3,  $R^2 = .13$ ,  $F_{ch}(1, 73) = 1.91$ .

Table 6: Children's Surgency as a Moderator of Deficient Parenting and Maternal Report of Aggressive Behaviors.

Predictor(s) entered	Step 1			Step 2			Step 3		
	$\beta$	<i>B</i>	<i>SE B</i>	$\beta$	<i>B</i>	<i>SE B</i>	$\beta$	<i>B</i>	<i>SE B</i>
Step 1 (covariates)									
Child Age	.07	.05	.08	.04	.03	.08	.04	.03	.08
Social Status	.01	.01	.11	.04	.04	.03	.03	.03	.11
MPQ PEM	-.08	-.09	.12	.04	.04	.13	.03	.04	.13
Step 2									
Deficient Parenting				.31*	.32*	.13	.31*	.33	.13
Surgency Factor				-.04	-.04	.12	-.05	-.05	.12
Step 3									
DefXSurgency							.05	.04	.12

Note. *F* and  $\beta$  are for the final equations, with all predictors entered. Child age, maternal social status, and mother's Positive Emotionality was entered in Step 1, deficient parenting and child's surgency was entered in Step 2, and the interaction between deficient parenting and child surgency was entered in Step 3.

\* $p < .05$ .

After Step 1,  $R^2 = .01$ ,  $F_{ch}(3, 73) = .28$ ; after Step 2,  $R^2 = .09$ ,  $F_{ch}(2, 71) = 3.05^*$ ; after Step 3,  $R^2 = .09$ ,  $F_{ch}(1, 70) = .14$ .

Table 7: Children's Effortful Control as a Moderator of Maternal Monitoring and Maternal Report of Aggressive Behaviors.

Predictor(s) entered	Step 1			Step 2			Step 3		
	$\beta$	<i>B</i>	<i>SE B</i>	$\beta$	<i>B</i>	<i>SE B</i>	$\beta$	<i>B</i>	<i>SE B</i>
Step 1 (covariates)									
Child Age	-.03	-.02	.11	-.22	-.18	.13	-.21	-.18	.14
Social Status	.05	.05	.16	.01	.01	.15	-.00	.00	.16
MPQ PEM	.06	.06	.14	.11	.11	.14	.11	.12	.15
Step 2									
Parental Monitor				.03	.03	.13	.03	.03	.13
EC Factor Score				-.34*	-.34	.16	-.34*	-.34	.17
Step 3									
MonXEC							-.05	-.05	.13

Note. *B* and  $\beta$  are for the final equations, with all predictors entered. Child age, maternal social status, and mother's Positive Emotionality was entered in Step 1, parental supervision and child's effortful control factor was entered in Step 2, and the interaction between parental supervision and effortful control was entered in Step 3.

\* $p < .05$ , \*\*  $p < .01$ .

After Step 1,  $R^2 = .01$ ,  $F_{ch}(3, 52) = .11$ ; after Step 2,  $R^2 = .09$ ,  $F_{ch}(2, 50) = 2.16$ ; after Step 3,  $R^2 = .09$ ,  $F_{ch}(1, 49) = .12$ .

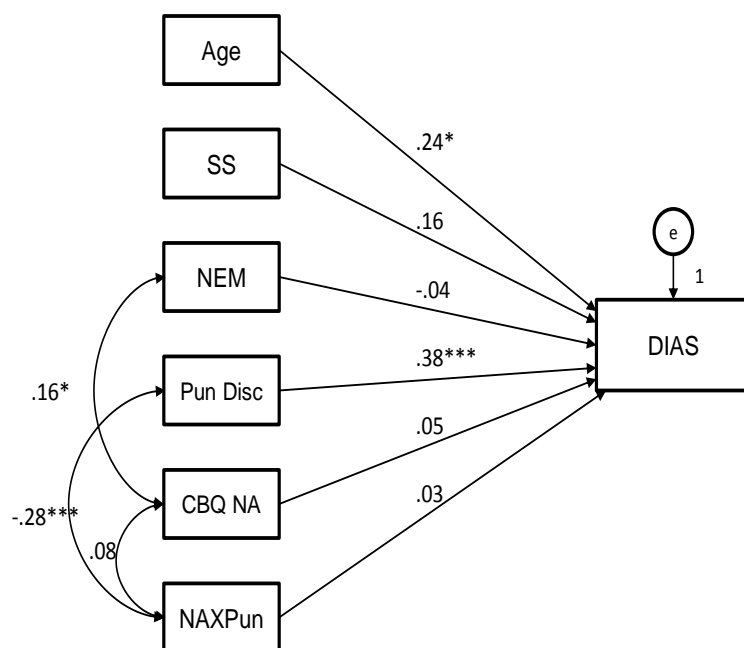

Figure 1: Main and Interaction Effects of Punitive Discipline and Child Negative Affectivity

NOTE: SS = Social Status; NEM = Multidimensional Personality Questionnaire Negative Emotionality, Pun Disc = Punitive Discipline Factor, CBQ NA = Children's Behavior Questionnaire Negative Affectivity Factor, NAXPun= Child Negative Affectivity Factor X Punitive Discipline Factor. DIAS = Direct and Indirect Aggression Scale—Direct Aggression.

Standardized regression weights shown.

$\chi^2 = 8.04$  (12),  $p = .78$ , CFI = 1.0, TLI = 1.0, IFI = 1.0, RMSEA = .00.

† $p < .10$ , \* $p < .05$ , \*\* $p < .01$ , \*\*\* $p < .001$ .

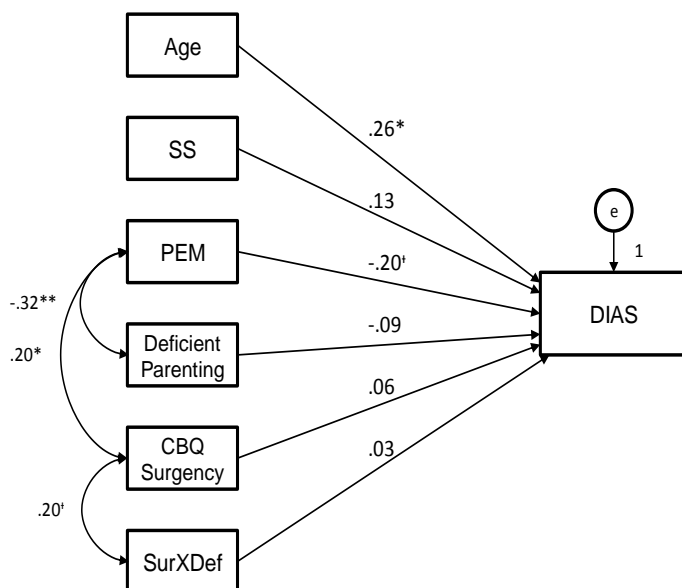

Figure 2: Main and Interaction Effects of Deficient Parenting and Child Surgency

NOTE: SS = Social Status; PEM = Multidimensional Personality Questionnaire Positive Emotionality, CBQ Surgency = Children's Behavior Questionnaire Surgency Factor, SurgeXDef = Child Surgency Factor X Deficient Parenting Factor, DIAS = Direct and Indirect Aggression Scale—Direct Aggression.

Standardized regression weights shown.

$\chi^2 = 12.32_{(12)}$ ,  $p = .42$ , CFI = .97, TLI = .93, IFI = .99, RMSEA = .02.

† $p < .10$ , \* $p < .05$ , \*\* $p < .01$ , \*\*\* $p < .001$ .

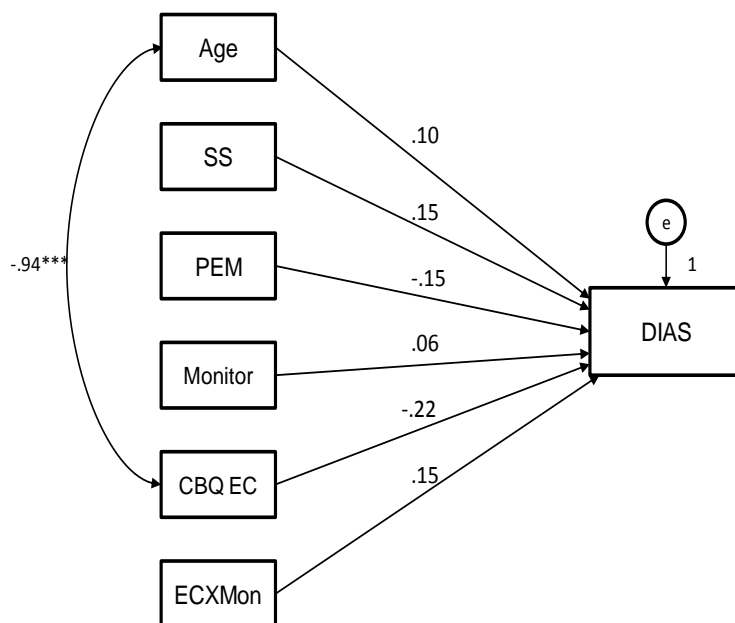

Figure 3: Main and Interaction Effects of Maternal Monitoring and Child Effortful Control

NOTE: SS = Social Status; PEM = Multidimensional Personality Questionnaire Positive Emotionality, Monitor = Parental Monitoring Factor, CBQ EC = Children's Behavior Questionnaire Effortful Control Factor, ECXMon= Child Effortful Control Factor X Maternal Monitoring Factor, DIAS = Direct and Indirect Aggression Scale—Direct Aggression.

Standardized regression weights shown.

$\chi^2 = 13.76_{(14)}$ ,  $p = .47$ , CFI = 1.0, TLI = 1.0, IFI = 1.0, RMSEA = .00.

† $p < .10$ , \* $p < .05$ , \*\* $p < .01$ , \*\*\* $p < .001$ .

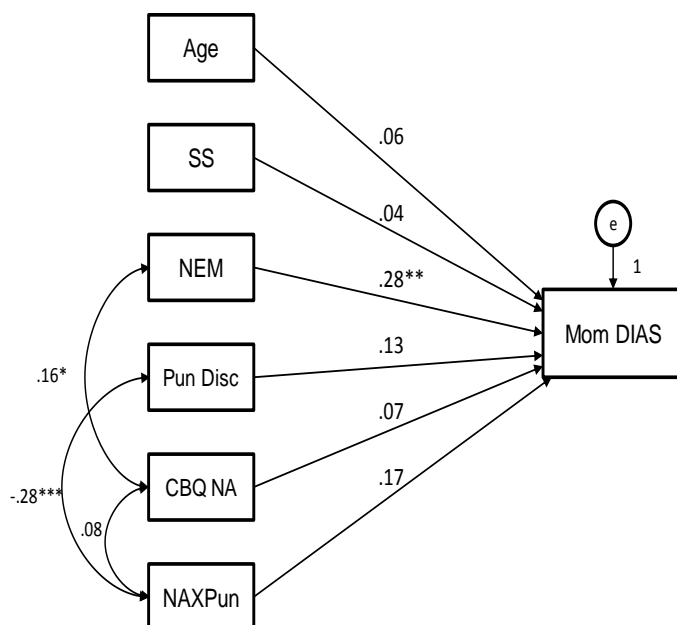

Figure 4: Main and Interaction Effects of Punitive Discipline and Child Negative Affectivity Using Mother Report of Child Aggression

NOTE: SS = Social Status; NEM = Multidimensional Personality Questionnaire Negative Emotionality, Pun Disc = Punitive Discipline Factor, CBQ NA = Children's Behavior Questionnaire Negative Affectivity Factor, NAXPun= Child Negative Affectivity Factor X Punitive Discipline Factor. Mom DIAS = Maternal report of Direct and Indirect Aggression Scale—Direct Aggression.

Standardized regression weights shown.

$\chi^2 = 8.36$  (12),  $p = .76$ , CFI = 1.0, TLI = 1.0, IFI = 1.10, RMSEA = .00.

\* $p < .05$ , \*\* $p < .01$ , \*\*\* $p < .001$ .



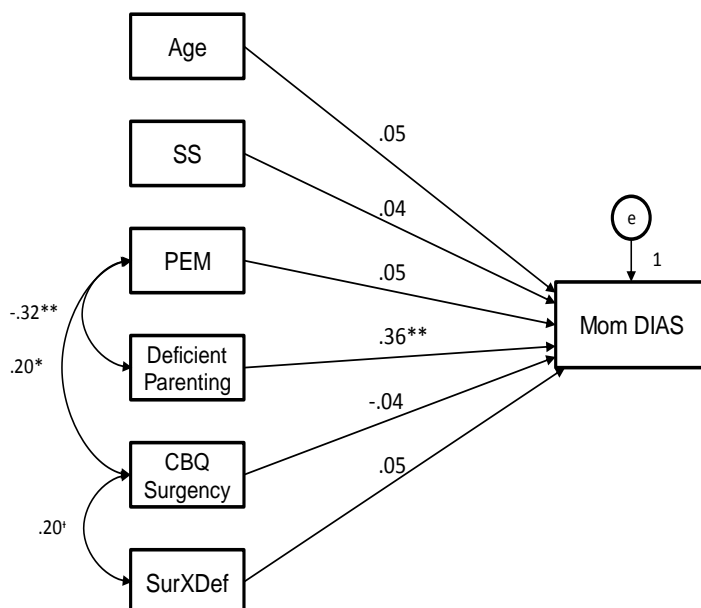

Figure 5: Main and Interaction Effects of Deficient Discipline and Child Surgency Using Mother Report of Child Aggression

NOTE: SS = Social Status; PEM = Multidimensional Personality Questionnaire Positive Emotionality, CBQ Surgency = Children's Behavior Questionnaire Surgency Factor, SurgeXDef = Child Surgency Factor X Deficient Parenting Factor, Mom DIAS = Maternal report of Direct and Indirect Aggression Scale—Direct Aggression.

Standardized regression weights shown.

$\chi^2 = 12.31_{(12)}$ ,  $p = .42$ , CFI = .97, TLI = .94, IFI = .99, RMSEA = .02.

† $p < .10$ , \* $p < .05$ , \*\* $p < .01$ , \*\*\* $p < .001$ .

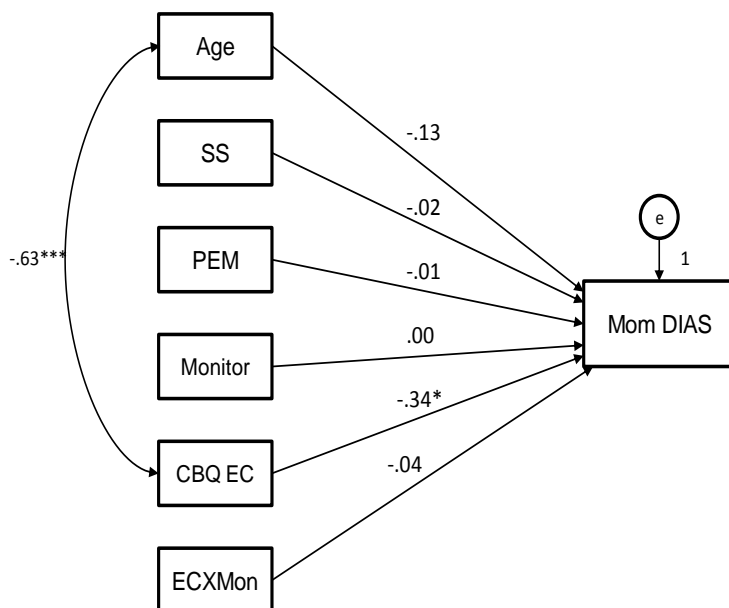

Figure 6: Main and Interaction Effects of Maternal Monitoring and Child Effortful Control Using Mother Report of Child Aggression

NOTE: SS = Social Status; PEM = Multidimensional Personality Questionnaire Positive Emotionality, Monitor = Parental Monitoring Factor, CBQ EC = Children's Behavior Questionnaire Effortful Control Factor, ECXMon= Child Effortful Control Factor X Maternal Monitoring Factor, Mom DIAS = Maternal report of Direct and Indirect Aggression Scale—Direct Aggression.

Standardized regression weights shown.

$\chi^2 = 14.52_{(14)}$ ,  $p = .41$ , CFI = .95, TLI = .90, IFI = .98, RMSEA = .02.

\* $p < .05$ , \*\* $p < .001$ .

## CHAPTER VIII

### DISCUSSION

Research has long been devoted to the person and process factors that contribute to negative childhood outcomes. One of the most commonly examined process factors is parenting (Bender et al., 2007; Chang et al., 2003; Cloninger et al., 1982; Knutson et al., 2005) and the most commonly researched person factor is child temperament (Eisenberg et al., 2001; Gilliom & Shaw, 2004; Lengua, 2006; Oldehinkel et al., 2004; Ormel et al., 2005). While earlier studies examined the main effects of each factor, this line of research has moved to understanding how the two factors might interact to potentiate negative outcomes such as aggressive behaviors. Thus, the current study examined the possible moderating role of child temperament on the relation between different forms of poor parenting practices and childhood aggressive behaviors.

#### Parenting and Aggressive Behaviors

The parenting practices examined in the present study were: harsh/punitive discipline, deficient parenting, and poor maternal monitoring, all of which have been associated with poor outcomes in children (Bates et al., 1998; Bender et al., 2007; Caron et al., 2006; Dishion, Duncan, Eddy, Fagot, & Fetrow, 1994; Grogan-Kaylor, 2004; Grogan-Kaylor, 2005; Hart, DeWolf, & Burts, 1992; Knutson, et al., 2005; Lansford et al., 2002), especially the relation between harsh/punitive discipline and aggression. The present study found support for the hypothesized relation between harsh discipline and aggressive behaviors, but not for deficient parenting or poor maternal monitoring, using child report of aggressive behaviors. That is, even after controlling for the significant effect of age, this study found a strong main effect for harsh punitive discipline in that

higher levels of punitive discipline predicted higher levels of childhood aggressive behaviors. This result was found using both regression analyses and path analyses that permitted full information maximum likelihood estimation. This finding is consistent with other studies that have found main effects for harsh discipline and externalizing disorders (Brook, Zheng, Whiteman, & Brook, 2001; Dodge, Pettit, & Bates, 1994; Fine, Trentacosta, Izard, Mostow, & Campbell, 2004; Stormshak, Bierman, McMahon, Lengua, & Conduct Problems Prevention Research Group, 2000). This mechanism could possibly be explained by the social learning theory in that children exposed to aggressive models tend to learn aggressive means to resolve conflict (Campbell et al., 2000) or continue to use aggressive behaviors due to negative reinforcement (Patterson, Reid, & Dishion, 1992). For example, studies have found that aggressive and coercive behaviors from the child tend to elicit harsh discipline, such as spankings and shouting, from parents (Reid, Patterson, & Snyder, 2002) which tends to contribute to the maintenance of aggressive behaviors in children by maintaining a reciprocal cycle of coercive behaviors (Patterson et al., 1992). Also, Simons and Wurtele (2010), found that parents who approve the use of corporal punishment and used corporal punishment with their children were associated with children's use of and acceptance of aggressive behaviors to resolve conflicts with peers and siblings. The resulting effect of using harsh discipline could be that parents fail to socialize a reduction in aggressive behaviors; thereby maintaining the use of aggressive behaviors in children (Tremblay, 2000) by inadvertently increasing a child's propensity to use aggressive behaviors (e.g., Loeber & Stouthamer-Loeber, 1986).

It should be noted that the Harsh Punitive Discipline construct included questions about yelling and spanking, as well as more abusive forms of discipline. However, other researchers, such as Deater-Deckard and Dodge (1997) and Stormshak et al. (2000), have advised examining spanking and abuse separately, as the severity of physical forms of discipline can determine the presence of aggressive behaviors. That is, some studies have found that non-injurious spankings (i.e., hitting a child on the buttocks with an open hand) are not deleterious (e.g., Baumrind, Larzelere, & Owens, 2010) and may be as harmless as using a timeout to correct a child's behavior (Larzelere & Kuhn, 2005). However, children who are recipients of severe physical discipline, or frequent and intense discipline which causes injury, can lead to poor outcomes in adolescence (Baumrind et al., 2010). Furthermore, a study conducted by Jaffee et al. (2004), found that while child behaviors, which included aggressive behaviors, tend to elicit the use of corporal punishment from parents, they do not elicit abusive discipline. Despite the recommendation that both should be examined separately, the current author chose to view punitive discipline as being along a continuum of severity, which is consistent with other research (e.g., Gelles & Straus, 1988, Greenwald, Bank, Reid, & Knutson, 1997; Whipple & Richey, 1997) and therefore opted to combine the two into one factor. Studies using a similar sample have also aggregated corporal punishment and physical abuse to create a punitive discipline factor (e.g., Knutson et al., 2005). Interestingly, a meta-analysis examining the relation between corporal punishment, which did not include severe forms of physical punishment, and childhood outcomes such as aggressive behaviors, found that corporal punishment and physical abuse are linked in that the use of corporal punishment increased the likelihood of using physical abuse (Gershoff, 2002).

Although only harsh discipline was a significant predictor of child aggression using child report, post-hoc analyses using maternal report of aggressive behaviors found a significant main effect for the Deficient Parenting construct. Results indicated that higher levels of deficient parenting, which was a multimethod construct, predicted higher levels of mother reported child aggressive behaviors. Deficient parenting, as used in this study, was comprised of maternal reported inconsistent discipline and a combination of self-report and directly observed neglectful conditions that could potentiate both environmental and social risks for the child. This finding is consistent with studies that have found that neglectful parenting can lead to negative childhood outcomes where maternal report contributes to the criterion measures (Knutson et al., 2005). Inconsistent parenting has also been linked to both aggressive behaviors (e.g., Gardner, 1989), noncompliant behaviors in children (e.g., Patterson et al., 1992; Chamberlain & Patterson, 1995), and abusive discipline (Reid, Tapline, & Lorber, 1981). Studies have found that parents that use abusive discipline also use inconsistent discipline more frequently when compared to non-abusive parents (Reid et al., 1981).

In a study examining cumulative risk factors, such as single parent status, ethnic minority, low parental educational attainment, financial hardship, and externalizing behaviors, inconsistent discipline partially mediated the direct relationship between cumulative risk and externalizing disorders (Dumka, Roosa, & Jackson, 1997). Therefore, it could be that lack of consistent limit setting, such as changing responses to an inappropriate behavior, not checking in when a child is playing outside, not communicating with the child about their day, and being left home alone, could lead to the use of aggressive behaviors due to lack of consistent parental discipline and lack of

socialization (e.g., Kuczynski, Kochanska, Radke-Yarrow, & Girnius-Brown, 1987; Patterson, 1986, Tremblay, 2000; Wahler & Dumas, 1986).

### Child Temperament and Child Aggressive Behaviors

Given the long-standing relation found between parenting and childhood outcomes in previous research and the finding that parenting does not by itself account for all or most of the variance in childhood outcomes (e.g., Boyle, Jenkins, Georgiades, Cairney, Duku, & Racine, 2004), research has also examined the mechanisms through which parenting exerts its effect on childhood outcomes (e.g., Aucoin et al., 2006; Kochanska, Forman, Aksan, & Dunbar, 2005; Rubin et al., 2003). The present study chose temperament as a possible moderator by which the risk of aggressive behaviors might be exacerbated, as temperament levels might create vulnerability in children when exposed to less than optimal parenting strategies.

Although numerous studies have found that temperament moderates the relation between parenting and negative childhood outcomes (Aucoin et al., 2006; Colder et al., 1997; Lengua et al., 2000; Ramos et al., 2005; Rubin et al., 2003, Stright et al., 2008), the present study was unable to replicate those findings. This study is not the first to find null effects for the association between negative affectivity and aggressive behaviors, as negative affectivity is strongly associated with internalizing disorders (e.g., Asendorpf & van Aken, 2003; Ruschena, Prior, Sanson, & Smart, 2005; Mun et al., 2001). However, both effortful control and surgency failed to predict child report of aggressive behaviors as well. Notably, few studies have examined the relation between surgency/extraversion and aggression (Lengua et al., 1998; Rothbart & Putnam, 2002), but that effortful control failed to predict aggressive behaviors is remarkable given that it has been repeatedly

linked to aggressive behaviors (Caspi et al., 1995; Eisenberg et al., 2001; Kochanska & Knaack, 2003; Oldehinkel et al., 2004). In fact, subscales of effortful control have been found to be stronger predictors of conduct problems when compared to negative emotionality (Lengua et al., 1998). The present study's inability to find a relation between temperament and aggression could have been due to a number of factors discussed below.

First, the failure to find an effect for temperament could be partly attributed to the relatively small sample size, especially for the effortful control hypothesis which had a sample size of 53. This sample size could have reduced power and could have precluded finding small effects. The present study was designed to examine moderation, but moderation analyses typically require larger sample sizes and, considering the variables used, the use of continuous variables could have also reduced power (Aguinis, Beaty, Boik, & Pierce, 2005; McClelland & Judd, 1993). Results of power analyses conducted prior to the implementation of this study established a sample size goal of at least 185, which would be required to fully conduct the planned analyses; however, only 85 participants could be obtained.

Another potential explanation for the finding that temperament did not predict aggressive behaviors could be due to the aggressive behavior criterion used. Specifically, child report of aggressive behaviors was used as opposed to maternal report, which some researchers might suggest is problematic due to children's tendency to underreport their use of aggressive behaviors (De Los Reyes & Kazdin, 2005; Taber, 2010). For example, children might underreport their use of aggressive behaviors because they do not recognize their behaviors as aggressive or do not want to appear aggressive to the



interviewer (De Los Reyes et al., 2005). Also, Brown and Kafer (1994) found that self-awareness, which can lead to improvements in the veridicality of self-report data, greatly increases at the age of 7 or 8 years-old and the age range of the present study was 5-10 years-old. Notably, the use of child report of aggressive behaviors was not originally intended to be the sole criterion measure. Originally, the aggressive behavior construct was conceptualized to be both multimethod and multisource. However, maternal report and child report of aggressive behaviors were not significantly correlated and since one goal was to maintain separate sources for the predictors and the criterion measures, child report was selected as the primary criterion. The lack of correlation between parent and child report could have been due to both different perspectives and causal attributions of the informants, or the methodology used to assess aggressive behaviors could have been more appropriate for adults and older children (De Los Reyes & Kazdin, 2005). Specifically, both children (ages 6 and up) and parents were asked to recall the last time the aggressive act was displayed by the child, which could have over relied on a child's recall ability and a parent's knowledge of the last episode (De Los Reyes & Kazdin, 2005). Also, in the De Los Reyes and Kazdin review, the authors noted that the use of different informants could result in the identification of different risk factors and predictors and since other studies have suggested examining multi-informant data separately as opposed to aggregated (Tremblay, 2000), the present study conducted post-hoc analyses using maternal report of aggressive behaviors as the criterion.

Interestingly, post-hoc analyses using maternal report of aggressive behaviors found a main effect for one temperament factor, effortful control, but also failed to find any moderating effects of temperament. These results indicated that high levels of

effortful control predicted maternal report of low levels of child aggressive behaviors. This finding is of particular interest since the predictor was created using a multisource methodology. That is, both maternal report and the child's performance on a behavioral task were aggregated to create the construct. The finding that effortful control predicted maternal report of aggressive behaviors is consistent with research that finds that when children are better able to regulate both their behavior and attention, they will be less likely to engage in aggressive behaviors (e.g., Eisenberg et al., 1994; Lengua, 2006). This finding, although not originally predicted, also lends support to the notion that data from different informants should be analyzed separately (Tremblay, 2000; Valles & Knutson, 2008). Using child data as the criterion, temperament did not evidence an effect on child aggression; however, when maternal report was used as the criterion, a multimethod construct of effortful control was a significant predictor of child aggression. Other studies that have found different results based on the informant used have suggested that the use of children's perspectives could be valuable as they can provide information that is not readily available to other informants (Achenbach, McConaughy, & Howell, 1987; Ladd, Kochenderfer-Ladd, 2002), as parents are limited to the context in which the behavior occurs (e.g., at home versus school). Future studies should examine whether high levels of effortful control can be a protective factor even when coupled with high negative affectivity. For example, Muris and Ollendick, (2005) hypothesized a model whereby inhibitory control, a component of effortful control, might moderate the effect of anger/frustration and disruptive behavior disorders.

## Age, Social Status, Maternal Personality, and Aggressive

### Behaviors

The present study also found significant contributions for the covariates of age, social status, and maternal personality included in the tests of the hypothesized models. For the model examining the Harsh Discipline and Negative Affectivity constructs, and for the model examining Deficient Parenting and Surgency constructs, age was found to be a significant predictor of aggressive behaviors. However, while most studies find a decline in aggression as children age (Côté, Vaillancourt, Barker, Nagin, & Tremblay, 2007; Côté, Vaillancourt, LeBlanc, Nagin, & Tremblay, 2006; Nagin & Tremblay, 1999), the current study found that older children reported using more aggressive behaviors compared to the younger children in the sample. If one places this finding in the context of the previous finding, that punitive discipline predicts aggressive behaviors, if mothers enrolled in the present study are more punitive than the general population due to their high risk status, the physical discipline reported by the mothers and children in the current study could account for the higher rates of aggressive behaviors reported by the older children in this sample (Côté et al., 2006; Valles & Knutson, 2009). That is, even though most studies find that the use of harsh discipline tends to decline as children get older (Gershoff, 2002), it could be that children, once exposed to punitive discipline, internalize the use of aggression as a means of solving problems (Campbell et al., 2000; Loeber & Stouthammer-Loeber, 1986; Simons & Wurtele, 2010), which attenuates the reduction of aggressive behaviors observed in other children (Côté et al., 2007; Côté et al., 2006; Nagin & Tremblay, 1999). Longitudinal data are needed to examine growth curves to determine if the children identified in samples such as the present sample are at

risk for maintaining aggressive behaviors across time (e.g., Côté et al., 2006). Another potential explanation for the significant age effect could be partly attributable to method variance and/or source bias. That is, the younger children in this sample could have underestimated their use of aggressive behaviors (De Los Reyes & Kazdin, 2005). In a review conducted by Taber (2010), the author examined factors that might impact the veridicality of child report and found that factors such as child age tend to influence the accuracy of child report, with older children being more reliable compared to younger children. Regarding method variance, the use of a Likert-type scale could also have affected child report of aggression in that younger children tend to gravitate to the tails of the scale, reporting in a yes or no type format (Chambers & Johnston, 2002). In their review of informant discrepancies, De Los Reyes and Kazdin stated that there is no “gold standard” for assessing child behaviors and offered suggestions to help minimize informant discrepancies by addressing perspective and attribution biases. Therefore, future studies could apply the strategies suggested by De Los Reyes and Kazdin (e.g., limiting the context in which the behavior occurs, examining the problematic nature of the behavior) to see if the proposed model helps elucidate predictors of aggressive behaviors in childhood across informants.

The final hypothesis tested was the relation between maternal monitoring and child effortful control in predicting child report of aggressive behaviors using hierarchical regression; found that only social status was significantly related to aggressive behaviors. However, the effect was not in the expected direction, with children on the higher end of the strata reporting higher usage of aggressive behaviors. Although this finding might appear to be inconsistent with studies that typically find that low levels of SES predict

aggressive behaviors and psychopathology (Brooks-Gunn & Duncan, 1997, Dodge et al., 1994; Hill et al., 2006; Patterson, DeBaryshe, & Ramsey, 1989; Santiago, Wadsworth, & Stump, 2011), the sample used in this study was entirely from a lower socioeconomic strata by design. That is, the families were recruited to be at high risk for negative outcomes based on having received state or county financial assistance and exposure to negative experiences such as domestic violence, physical abuse and/or neglect. Therefore, the finding that social status predicted aggressive behaviors is actually not inconsistent with studies that find that children from low SES homes are at risk for negative outcomes (e.g., Dodge et al., 1994). However, research has found that the relation between SES and aggressive behaviors might not be direct, which is known as the problem of the third variable (Bradley & Corwyn, 2002). For example, one such study examined the relation between social status and aggressive behavior using an adolescent sample and found that shaming experiences, defined as being the recipient of insults and/or ridicule, mediated the relation between social status and aggressive behaviors for those with high *and* low social status (Aslund et al., 2009). Therefore, it could be that other potential mediators and moderators not examined in the present study could account for this relation (e.g., Bradley & Corwyn, 2002). Notably, these results were not replicated using structural equation modeling, which increased the sample size from  $n = 53$  to  $n = 85$ ; therefore, this finding should be interpreted with caution, as this finding could be attributed to a Type I error.

Maternal personality was also a significant predictor in some of the analyses conducted using either child report or maternal report of aggressive behaviors. For analyses using maternal report, the present study found that higher levels of maternal

Negative Emotionality predicted higher levels of child aggression. This finding is consistent with studies that find a relation between maternal negative affect and poor child outcomes (e.g., Denham, Workman, Cole, Weissbrod, Kendziora, & Zahn-Waxler, 2000; Malatesta & Haviland, 1986; Mullineaux, Deater-Deckard, Petrill, & Thompson, 2009). Given that negative emotionality can be defined as the manner in which an individual perceives or reacts to distressing or threatening situations (Watson, Clark, & Chmielewski, 2008), and some of its lower-level traits are aggression and stress reactivity, it could be that mothers model for their children responding to events in a negative manner which contributes to the child's propensity to become dysregulated in the presence of a stressor (e.g., Zahn-Waxler et al., 1990). However, this statement requires an analysis of the lower level traits of negative emotionality. Alternatively, this finding could also be explained as being shared genetic material. Given that the mother provided information for both the predictor and the criterion, this finding could also be attributable to shared method variance (De Los Reyes & Kazdin, 2005) or to the mother's propensity to focus on negative aspects of their child when self-described as negative (Fergusson, Lynskey, & Horwood, 1993; Najman, Williams, Nikles, Spence, Bor, O'Callaghan, et al., 2001). Therefore, this finding could lend support to De Los Reyes' and Kazdin's finding that bias exists in all informants used; therefore, multiple informants should be considered when examining child behaviors (De Los Reyes & Kazdin, 2005; Taber, 2010).

Regarding positive emotionality, using child report of aggressive behaviors, maternal positive emotionality was a marginally significant predictor of aggressive behaviors. That is, higher levels of positive emotionality, which is an individual's ability

to engage the social environment (Watson et al., 2008), marginally predicted lower levels of aggressive behavior. This finding is somewhat consistent with research implicating maternal warmth and positive affect as a protective factor against child aggressive behaviors (e.g., Mullineaux et al., 2009). For example, Kochanska's research that has examined the effects of mutually responsive orientation, which is parent-child relationship characterized as having reciprocal positive affect, has found that mutually responsive orientation helps socialize children who are characterized as "fearless" (Kochanska, 1995). Therefore, if a child tends to resort to aggression, a parent can rely on the positive relationship to reduce the use of aggression in the child. However, this finding should be interpreted with caution as it was only marginally significant.

### Conclusions

The current study attempted to correct some of the limitations present in studies examining main and interactive effects of parenting and temperament on child aggressive behaviors. First, the study examined multiple forms of parenting, which included harsh discipline, poor monitoring, and deficient parenting, with different temperament factors. Second, the present study, when possible, employed a multimethod and multisource design to reduce the possibility of shared method variance or source bias in the results. Third, the present study also controlled for other person and process factors that have been found to contribute to aggressive behaviors, specifically, age, gender, social status, and maternal personality. While unable to identify moderating effects of child temperament, the study contributed to the growing body of research that shows that harsh/punitive discipline places children at risk for the use of aggressive behaviors. This

finding strengthens the need to address age appropriate and effective parenting strategies for children referred to treatment for aggressive behaviors.

Using maternal report of aggressive behaviors, this study also found evidence supporting the relation between effortful control as a protective factor against aggressive behaviors (Eisenberg, Zhou, Spinrad, Valiente, Fabes, & Liew, 2005; Lengua, 2008). Therefore, treatment of aggressive behaviors should include a component to help children improve effortful control, particularly inhibitory control (Muris & Ollendick, 2005; Rothbart, 2004). Furthermore, that maternal personality and deficient parenting predicted aggressive behavior is also an important finding that has implications for treatment. Specifically, treatment should continue to focus on improving the mother-child relationship by increasing positive parenting behaviors characterized as being warm and consistent (Zisser & Eyberg, 2010). Given the different results found using different informants, future studies should examine data from different sources in a nonaggregated manner (Tremblay, 2000), while taking into consideration the suggestions offered by De Los Reyes and Kazdin (2005) to reduce informant discrepancies. Future studies should also examine other possible mediators and moderators, for example, the child's positive attitudes towards the use of aggressive behaviors, of the relation between aggressive behaviors and parenting factors using a multisource and multimethod methodology.



## REFERENCES

- Achenbach, T.M. (1991). *Manual for the Teacher's Report Form and 1991 Profile*. Burlington, VT: Department of Psychology, University of Vermont.
- Achenbach, T.M., McConaughy, S.H., & Howell, C.T. (1987). Child/adolescent behavioral and emotional problems: Implications of cross-informant correlations for situational specificity. *Psychological Bulletin*, *101*, 213-232.
- Aguinis, H., Beaty, J. C., Boik, R. J., & Pierce, C. A. (2005). Effect size and power in assessing moderating effects of categorical variables using multiple regression: A 30-year review. *Journal of Applied Psychology*, *90*, 94-107.
- Ahadi, S.A., Rothbart, M.K., & Ye, R.M. (1993). Children's temperament in the U.S. and China: Similarities and differences. *European Journal of Personality*, *7*, 359-377.
- American Psychiatric Association. (2000). *Diagnostic and statistical manual of mental disorders* (4<sup>th</sup> ed., text rev.). Washington, DC: American Psychiatric Association.
- Aslund, C., Starrin, B., Leppert, J., & Nilsson, K.W. (2009). Social status and shaming experiences related to adolescent overt aggression at school. *Aggressive Behavior*, *35*, 1-13.
- Asendorpf, J.B. & van Aken, M.A.G. (2003). Personality-relationship translation in adolescence: Core versus surface personality characteristics. *Journal of Personality*, *71*, 629-666.
- Aucoin, K.J., Frick, P.J., & Bodin, S.D. (2006). Corporal punishment and child adjustment. *Journal of Applied Developmental Psychology*, *27*, 527-541.
- Bandura, A. & Walters, R.H. (1959). *Adolescent aggression: a study of the influence of child-training practices and family interrelationships*. Oxford, England: Ronald Press.
- Bates, J.E., Pettit, G.S., & Dodge, K.A. (1995). Family and child factors in stability and change in children's aggressiveness in elementary school. In McCord, Joan (Ed), *Coercion and Punishment in Long-term Perspectives*. (pp. 124-138). New York, NY, US: Cambridge University Press.
- Bates, J.E., Pettit, G.S., Dodge, K.A., & Ridge, B. (1998). Interaction of temperamental resistance to control and restrictive parenting in the development of externalizing behavior.
- Baumrind, D., Larzelere, R.E., & Owens, E.B. (2010). Effects of preschool parents' power assertive patterns and practices on adolescent development. *Parenting: Science and Practice*, *10*, 157-201.
- Belsky, J. (2005). Differential susceptibility to rearing influence: An evolutionary hypothesis and some evidence. In B.J. Ellis & D.F. Bjorklund (Eds.), *Origins of the social mind: Evolutionary psychology and child development* (pp.139-163). New York: Guilford Press.

- Bender, H.L., Allen, J.P., McElhaney, K.B., Antonishak, J., Moore, C.M., Kelly, H.O., & Davis, S.M. (2007). Use of harsh physical discipline and developmental outcomes in adolescence. *Development and Psychopathology, 19*, 227-242.
- Beyers, J.M., Loeber, R., Wikstrom, P.H., & Stouthamer-Loeber, M. (2001). What predicts adolescent violence in better-off neighborhoods? *Journal of Abnormal Child Psychology, 29*, 369-381.
- Bezdjian, S., Baker, L.A., Lozano, D.I., & Raine, A. (2009). Assessing inattention and impulsivity in children during the Go/NoGo task. *British Journal of Developmental Psychology, 27*, 365-383.
- Björkqvist, K., Lagerspetz, K.M., & Kaukiainen, A. (1992). Do girls manipulate and boys fight? Developmental trends in regard to direct and indirect aggression. *Aggressive Behavior, 18*, 117-127.
- Björkqvist, K., Lagerspetz, K.M., & Österman, K. (1992). The Direct and Indirect Aggression Scales (DIAS). Vasa, Finland: Abo Academy University, Department of Social Sciences.
- Blair, K.A., Denham, S.A., Kochanoff, A., & Whipple, B. (2004). Playing it cool: Temperament, emotion regulation, and social behavior in preschoolers. *Journal of School Psychology, 42*, 419-443.
- Bollen, K.A. (1989). *Structural equations with latent variables*. New York: John Wiley & Sons.
- Boucugnani, L. L., & Jones, R. W. (1989). Behaviors analogous to frontal lobe dysfunction in children with attention deficit hyperactivity disorder. *Archives of Clinical Neuropsychology, 4*, 161-173.
- Boyle, M.H., Jenkins, J.M., Georgiades, K., Cairney, J., Duku, E., & Racine, Y. (2004). Differential – maternal parenting behavior: Estimating within- and between-family effects on children. *Child Development, 75*, 1457-1476.
- Bradley, R.H., & Corwyn, R.F. (2002). Socioeconomic status and child development. *Annual Review of Psychology, 53*, 371-399.
- Brook, J.S., Zheng, L., Whiteman, M., & Brook, D.W. (2001). Aggression in toddlers: Associations with parenting and marital relations. *Journal of Genetic Psychology, 162*, 228-241.
- Brooks-Gunn J. & Duncan, G.J. (1997). The effects of poverty on children. *Future Child, 7*, 55-71.
- Brown, W. & Kafer, W.F. (1994). Self-discrepancies and perceived peer acceptance. *Journal of Psychology, 128*, 439-446.
- Burhans, K. & Dweck, C.S. (1995). Helplessness in early childhood: The role of contingent worth. *Child Development, 66*, 1719-1738.

- Bush, G., Frazier, J. A., Rauch, S. L., Seidman, L. J., Whalen, P. J., Jenike, M. A., Rosen, B. R., & Biederman, J. (1999). Anterior cingulate cortex dysfunction in attention deficit/hyperactivity disorder revealed by rMRI and the counting Stroop. *Biological Psychiatry*, *45*, 1542-1552.
- Buss, A. H., & Plomin, R. (1984). *Temperament: Early developing personality traits*. Hillsdale, NJ: Erlbaum.
- Caldwell, B.M., & Bradley, R.H. (1978). *Home observation and measurement of the environment*. Little Rock: University of Arkansas Press.
- Campbell, S.B., Shaw, D.S., & Gilliom, M. (2000). Early externalizing behavior problems: Toddlers and preschoolers at risk for later maladjustment. *Developmental Psychopathology*, *12*, 467-488.
- Cairns, R. B. (1979). *Social development: The origins and plasticity of interchanges*. San Francisco: Freeman.
- Caron, A., Weiss, B., Harris, V., & Catron, T. (2006). Parenting behavior dimensions and child psychopathology: Specificity, task dependency, and interactive relations. *Journal of Clinical Child and Adolescent Psychology*, *35*, 34-45.
- Carter, C. S., Krener, P., Chaderjian, M., Northcutt, C., & Wolfe, V. (1995). Abnormal processing of irrelevant information in attention deficit hyperactivity disorder. *Psychiatry Research*, *56*, 59-70.
- Caspi, A., Henry, B., McGee, R.O., Moffitt, T.E., & Silva, P.A. (1995). Temperamental origins of child and adolescent behavior problems: From age three to fifteen. *Child Development*, *66*, 55-68.
- Caspi, A., Roberts, B.W., & Shiner, R.L. (2005). Personality development: stability and change. *Annual Review of Psychology*, *56*, 453-484.
- Caspi, A. & Silva, P.A. (1995). Temperamental qualities at age three predict personality traits in young adulthood: Longitudinal evidence from a birth cohort. *Child Development*, *66*, 486-498.
- Chamberlain, P. & Patterson, G.R. (1995). Discipline and child compliance in parenting. In M.H. Bornstein (Ed.), *Handbook of parenting, Vol. 4: Applied and practical parenting* (pp. 205-225). Hillsdale, NJ, England: Lawrence Erlbaum Associates, Inc.
- Chambers, C.T. & Johnston, C. (2002). Developmental differences in children's use of rating scales. *Journal of Pediatric Psychology*, *27*, 27-36.
- Chang, L., Schwartz, D., Dodge, K.A., & McBride-Chang, C. (2003). Harsh parenting in relation to child emotion regulation and aggression. *Journal of Family Psychology*, *17*, 598-606.
- Clark, L.A. (2005). Temperament as a unifying basis for personality and psychopathology. *Journal of Abnormal Psychology*, *11*, 505-521.
- Clement, P. & Richard, R. (1976). Identifying reinforcers for children: A children's reinforcement survey. In E. Mash & R. Terdal (Eds.), *Behavior therapy assessment: Diagnosis, design, and evaluation* (pp. 207-216). New York: Springer.

- Cloninger, C.R., Sigvardsson, S., Bohman, M., & von Knorring, A. (1982). Predisposition to petty criminality in Swedish adoptees: II. Cross-fostering analysis of gene-environment interaction. *Archives of General Psychiatry*, *39*, 1242-1247.
- Colder, C.R., Lochman, J.E., & Wells, K.C. (1997). The moderating effects of children's fear and activity level on relations between parenting practices and childhood symptomatology. *Journal of Abnormal Child Psychology*, *25*, 251-263.
- Cornell, A.H. & Frick, P.J. (2007). The moderating effects of parenting styles in the association between behavioral inhibition and parent-reported guilt and empathy in preschool children. *Journal of Clinical Child and Adolescent Psychology*, *36*, 305-318.
- Côté, S., Tremblay, R.E., Nagin, D., Zoccolillo, M., & Vitaro, F. (2002). The development of impulsivity, fearfulness, and helpfulness during childhood: patterns of consistency and change in the trajectories of boys and girls. *Journal of Child Psychology and Psychiatry*, *43*, 609-618.
- Côté, S.M., Vaillancourt, T., Barker, E.D., Nagin, D., & Tremblay, R.E. (2007). The joint development of physical and indirect aggression: Predictors of continuity and change during childhood. *Development and Psychopathology*, *19*, 37-55.
- Côté, S., Vaillancourt, T., LeBlanc, J.C., Nagin, D.S., & Tremblay, R.E. (2006). The development of physical aggression from toddlerhood to pre-adolescence: A nation wide longitudinal study of Canadian children. *Journal of Abnormal Child Psychology*, *34*, 68-82.
- Crick, N. R., & Dodge, K. A. (1994). A review and reformulation of social information-processing mechanisms in children's social adjustment. *Psychological Bulletin*, *115*, 74-101.
- Culp, R. E., Howell, C. S., Culp, A.M., & Blankemeyer, M. (2001). Maltreated children's emotional and behavioral problems: Do teachers and parents see the same thing?. *Journal of Child and Family Studies*, *10*, 39-50.
- Das, J. P., Snyder, T. J., & Mishra, R. K. (1992). Assessment of attention: Teachers' rating scales and measures of selective attention. *Journal of Psychoeducational Assessment*, *10*, 37-46.
- De Los Reyes, A. & Kazdin, A.E. (2005). Informant discrepancies in the assessment of childhood psychopathology: a critical review, theoretical framework, and recommendations for further study.
- Deater-Deckard, K. & Dodge, K.A. (1997). Externalizing behavior problems and discipline revisited: Nonlinear effects and variation by culture, context, and gender. *Psychological Inquiry*, *8*, 161-175.
- Denham, S.A., Workman, E., Cole, P.M., Weissbrod, C., Kendrion, K.T., & Zahn-Waxler, C. (2000). Prediction of externalizing behavior problems from early to middle childhood: The role of parental socialization and emotion expression. *Development and Psychopathology*, *12*, 23-45.
- DiLalla, L. F. & Gottesman, I. I. (1991). Biological and genetic contributors to violence: Widom's untold tale. *Psychological Bulletin*, *109*, 125-129.

- Dishion, T.J., Duncan, T.E., Eddy, J.M., Fagot, B.I., & Fetrow, R. (1994). The world of parents and peers: Coercive exchanges and children's social adaptation. *Social Development, 3*, 255-268.
- Dodge, K.A. (2002). Mediation, moderation, and mechanisms in how parenting affects children's aggressive behavior. In J.G. Borkowski, S.L. Ramey, & M. Bristol-Power (Eds.), *Parenting and the child's world: Influences on academic, intellectual and social development* (pp.215-229). Mahwah, NJ: Erlbaum.
- Dodge, K. A., Bates, J. E., & Pettit, G. S. (1990). Mechanisms in the cycle of violence. *Science, 250*, 1678–1683.
- Dodge, K. A., & Coie, J. D. (1987). Social information processing factors in reactive and proactive aggression in children's peer groups. *Journal of Personality and Social Psychology, 53*, 1146–1158.
- Dodge, K.A., Pettit, G.S., & Bates, J.E. (1994). Socialization mediators of the relation between socioeconomic status and child conduct problems. *Child Development, 65*, 649-665.
- Dodge, K.A., Pettit, G.S., Bates, J.E., & Valente, E. (1995). Social information-processing patterns partially mediate the effect of early physical abuse on later conduct problems. *Journal of Abnormal Psychology, 104*, 632-643.
- Dumka, L.E., Roosa, M.W., & Jackson, K.M. (1997). Risk, conflict, mother's parenting, and children's adjustment in low-income, Mexican immigrant and Mexican American families. *Journal of Marriage and the Family, 59*, 309-323.
- Eisenberg, N., Cumberland, A., Spinard, T.L., Fabes, R.A., Shepard, S.A., Reiser, M., et al. (2001). The relations of regulation and emotionality to children's externalizing and internalizing behavior problems. *Child Development, 72*, 1112-1134.
- Eisenberg, N., Fabes, R.A., Nyman, M., Bernzweig, J., & Pinuelas, A. (1994). The relations of emotionality and regulation to children's anger-related reactions. *Child Development, 65*, 109-128.
- Eisenberg, N., Fabes, R. A., Schaller, M., Miller, P. A., Garlo, G., Poulin, R., Shea, G., & Shell, R. (1991). Personality and socialization correlates of vicarious emotional responding. *Journal of Personality and Social Psychology, 61*, 459-471.
- Eisenberg, N., Zhou, Q., Spinrad, T.L., Valiente, C., Fabes, R.A., & Liew, J. (2005). Relations among positive parenting, children's effortful control, and externalizing problems: A three-wave longitudinal study. *Child Development, 76*, 1055-1071.
- Ellis, L.K. & Rothbart, M.K., (2001). Revision of the early adolescent temperament questionnaire. *Poster presented at the biennial meeting of the society for research in child development*. Minneapolis, MN.
- Else-Quest, N.M., Hyde, J.S., Goldsmith, H. H., & Van Hulle, C.A. (2006). Gender differences in temperament: a meta-analysis. *Psychological Bulletin, 132*, 33-72.
- Fergusson, D.M., Lynskey, M.T., & Horwood, L.J. (1993). The effect of maternal depression on maternal ratings of child behavior. *Journal of Abnormal Child Psychology, 21*, 245-269.

- Fine, S.E., Trentacosta, C.J., Izard, C.E., Mostow, A.J., & Campbell, J.L. (2004). Anger perception, caregiver's use of physical discipline, and aggression in children at risk. *Social Development, 13*, 213-228.
- Frick, P.H. & Morris, A.S. (2004). Temperament and developmental pathways to conduct problems. *Journal of Clinical Child and Adolescent Psychology, 33*, 54-68.
- Frick, P.H., O'Brien, B.S., Wotton, J.M., & McBurnett, K. (1994). Psychopathy and conduct problems in children. *Journal of Abnormal Psychology, 24*, 230-236.
- Gallagher, K.C. (2002). Does child temperament moderate the influence of parenting on adjustment? *Developmental Review, 22*, 623-643.
- Gallup, G.H.J., Moore, D.W., & Schussel, R. (1995). Disciplining children in America: A Gallup poll report. Princeton, NJ: The Gallup Organization.
- Gardner, F.E.M. (1989). Inconsistent parenting: Is there evidence for a link with children's conduct problems? *Journal of Abnormal Child Psychology, 17*, 223-233.
- Gardner, T.W., Dishion, T.J., & Connell, A.M. (2008). Adolescent self-regulation as resilience: Resistance to antisocial behavior within the deviant peer context. *Journal of Abnormal Child Psychology, 36*, 273-284.
- Gelles, R.J. & Straus, M.A. (1988). *Intimate Violence*. New York: Simon and Schuster.
- Gershoff, E.T. (2002). Corporal punishment by parents and associated child behaviors and experiences: a meta-analytic and theoretical review. *Psychological Bulletin, 128*, 539-579.
- Gerstadt, C. L., Hong, Y. J., & Diamond, A. (1994). The relationship between cognition and action: Performance of children 3 1/2 -7 years old on a Stroop-like day-night test. *Cognition, 53*, 129-153.
- Gilliom, M. & Shaw, D.S. (2004). Codevelopment of externalizing and internalizing problems in early childhood. *Development and Psychopathology, 16*, 313-333.
- Goldsmith, H.H., Buss, K.A., & Lemery, S. (1997). Toddler and childhood temperament: expanded content, stronger genetic evidence, new evidence for the importance of environment. *Developmental Psychology, 33*, 891-905.
- Goldsmith, H.H., Reilly, J., Lemery, K.S., Longley, S., & Prescott, A. (1993). Preliminary manual for Preschool Laboratory Temperament Assessment Battery. Madison: University of Wisconsin.
- Greenwald, R.L., Bank, L., Reid, J.B., & Knutson, J.F. (1997). A discipline-mediated model of excessively punitive parenting. *Aggressive Behavior, 23*, 259-280.
- Grogan-Kaylor, A. (2004). The effect of corporal punishment on antisocial behavior in children. *Social Work Research, 28*, 153-162.
- Grogan-Kaylor, A. (2005). Corporal punishment and the growth trajectory of children's antisocial behavior. *Child Maltreatment, 10*, 283-292.

- Hall, L. (1986). *Parent awareness of children's activities and preferences*. Unpublished doctoral dissertation, University of Iowa, Iowa, City.
- Hart, C.H., DeWolf, D.M., & Burts, D.C. (1992). Linkages among preschoolers' playground behavior, outcome expectations, and parental disciplinary style. *Early Education and Development, 3*, 265-283.
- Hayden, E.P., Klein, D.N., & Durbin, C.E. (2005). Parent reports and laboratory assessments of child temperament: A comparison of their associations with risk for depression and externalizing disorders. *Journal of Psychopathology and Behavioral Assessment, 27*, 89-100.
- Hill, A.L., Degnan, K.A., Calkins, S.D., & Keane, S.P. (2006). Profiles of externalizing behavior problems for boys and girls across preschool: The roles of emotion regulation and inattention. *Developmental Psychology, 42*, 913-928.
- Jaffee, S.R. (2002). Pathways to adversity in young adulthood among early childbearers. *Journal of Family Psychology, 16*, 38-49.
- Jaffee, S.R., Belsky, J., Harrington, H., Caspi, A., & Moffitt, T.E. (2006). When parents have a history of conduct disorder: How is the caregiving environment affected? *Journal of Abnormal Psychology, 115*, 309-319.
- Jaffee, S.R., Caspi, A., Moffitt, T.E., Polo-Thomas, M., & Price, T.S. (2004). The limits of child effects: Evidence for genetically mediated child effects on corporal punishment but not on physical maltreatment. *Developmental Psychology, 40*, 1047-1058.
- Jaffee, S. R., Caspi, A., Moffitt, T.E., & Taylor, A. (2004). Physical maltreatment victim to antisocial child: evidence of an environmentally mediated process. *Journal of Abnormal Psychology, 113*, 44-55.
- Karp, J., Serbin, L.A., Stack, D.M., & Schwartzman, A.E. (2004). An observational measure of children's behavioural style: Evidence supporting a multi-method approach to studying temperament. *Infant and Child Development, 13*, 135-158.
- Kendler, K.S., Sham, P.C., & MacLean, C.J. (1997). The determinants of parenting: An epidemiological, multi-informant, retrospective study. *Psychological Medicine, 27*, 549-563.
- Knutson, J.F., Degarmo, D., Koepl, G., & Reid, J.B. (2005). Care neglect, supervisory neglect, and harsh parenting in the development of children's aggression: A replication and extension. *Child Maltreatment, 10*, 92-107.
- Knutson, J.F., Taber, S.M., Murray, A.J., Valles, N., & Koepl, G. (2010). The role of care neglect and supervisory neglect in childhood obesity in a disadvantaged sample. *Journal of Pediatric Psychology, 35*, 523-532.
- Knutson, J.F., & Zaidi, L.Y. (1989). *The parenting task: A video test of parenting and discipline*. Iowa City, IA: University of Iowa Video Center.
- Kochanska, G. (1995). Children's temperament, mother's discipline, and security of attachment: Multiple pathways to emerging internalization. *Child Development, 66*, 597-615.

- Kochanska, G. (2001). Emotional development in children with different attachment histories: The first three years. *Child Development, 72*, 474-490.
- Kochanska, G., Aksan, N., & Joy, M.E. (2007). Children's fearfulfulness as a moderator of parenting in early socialization: Two longitudinal studies. *Developmental Psychology, 43*, 222-237.
- Kochanska, G., Aksan, N., Penney, S.J., & Doobay, A.F. (2007). Early positive emotionality as a heterogeneous trait: Implications for children's self-regulation. *Journal of Personality and Social Psychology, 93*, 1054-1066.
- Kochanska, G., Clark, L.A., & Goldman, M.S. (1997). Implications of mothers' personality for their parenting and their young children's development outcomes. *Journal of Personality, 65*, 387-420.
- Kochanska, G., DeVet K., Goldman, M., Murray, K.T., & Putnam, S.P. (1994). Maternal reports of conscience development and temperament in young children. *Child Development, 65*, 164-181.
- Kochanska, G., Forman, D.R., Aksan, N., & Dunbar, S.B. (2005). Pathways to conscience: early mother-child mutually responsive orientation and children's moral emotion, conduct, and cognition. *Journal of Child Psychology and Psychiatry, 46*, 19-35.
- Kochanska, G., Murray, K.T., & Harlan, E.T. (2000). Effortful control in early childhood: continuity and change, antecedents, and implications for social development. *Developmental Psychology, 36*, 220-232.
- Kochanska, G. & Knaack, A. (2003). Effortful control as a personality characteristic of young children: antecedents, correlates, and consequences. *Journal of Personality, 71*, 1087-1112.
- Krueger, R.F., Caspi, A., Moffitt, T.E., & Silva, P.A. (1998). The structure and stability of common mental disorders (DSM-III-R): A longitudinal-epidemiological study. *Journal of Abnormal Psychology, 107*, 216-227.
- Kuczynski, L., Kochanska, G., Radke-Yarrow, M., & Girmius-Brown, O. (1987). A developmental interpretation of young children's noncompliance. *Developmental Psychology, 23*, 799-806.
- La Greca, A. M., & Stone, W. L. (1992). Assessing children through interviews and behavioral observations. In Walker C. E. and Roberts M. C. (Eds.), *Handbook of Clinical Child Psychology* (2<sup>nd</sup> ed.), New York: John Wiley & Sons, Inc.
- Ladd, G.W. & Kochenderfer-Ladd, B. (2002). Identifying victims of peer aggression from early to middle childhood: Analysis of cross-informant data for concordance, estimation of relational adjustment, prevalence of victimization, and characteristics of identified victims. *Psychological Assessment, 14*, 74-96.
- Lagerspetz, K. M. J., Björkqvist, K., & Peltonen, T. (1988). Is indirect aggression typical of females? Gender differences in aggressiveness in 11- to 12-year-old children. *Aggressive Behavior, 14*, 403-414.



- Laing, J.A., & Sines, J.O. (1982). The Home Environment Questionnaire: An instrument for assessing several behavioral relevant dimensions of children's environments. *Journal of Pediatric Psychology, 7*, 424-449.
- Lansbergen, M.M., Kenemans, J.L., & van Engeland, H. (2007). Stroop interference and attention-deficit/hyperactivity disorder: A review and meta-analysis. *Neuropsychology, 21*, 251-262.
- Lansford, J.E., Dodge, K.A., Pettit, G.S., Bates, J.E., Crozier, J., & Kaplow, J. (2002). Longterm effects of early child physical maltreatment on psychological, behavioral, and academic problems in adolescence: A 12-year prospective study. *Archives of Pediatric and Adolescent Medicine, 156*, 824-830.
- Larzelere, R.E., & Kuhn, B.R. (2005). Comparing child outcomes of physical punishment and alternative disciplinary tactics: A meta-analysis. *Clinical Child and Family Psychology Review, 8*, 1-37.
- Lengua, L.J. (2006). Growth in temperament and parenting as predictors of adjustment during children's transition to adolescence. *Developmental Psychology, 42*, 819-832.
- Lengua, L.J. (2008). Anxiousness, frustration, and effortful control as moderators of the relation between parenting and adjustment in middle-childhood. *Social Development, 17*, 554-577.
- Lengua, L.J., Bush, N.R., Long, A.C., Kovacs, E.A., & Trancik, A.M. (2008). Effortful control as a moderator of the relation between contextual risk factors and growth in adjustment problems. *Development and Psychopathology, 20*, 509-528.
- Lengua, L.J., Honorado, E., & Bush, N.R. (2007). Contextual risk and parenting as predictors of effortful control and social competence in preschool children. *Journal of Applied Developmental Psychology, 28*, 40-55.
- Lengua, L. J., West, S.G., & Sandler, I.N. (1998). Temperament as a predictor of symptomatology in children: addressing contamination of measures. *Child Development, 69*, 164-181.
- Lengua, L.J. & Kovacs, E.A. (2005). Bidirectional associations between temperament and parenting and the prediction of adjustment problems in middle childhood. *Applied Developmental Psychology, 26*, 21-38.
- Lengua, L.J., Wolchik, S.A., Sandler, I.N., & West, S.G. (2000). The additive and interactive effects of parenting and temperament in predicting problems of children of divorce. *Journal of Clinical Child Psychology, 29*, 232-244.
- Leventhal, T., Selner-O'Hagan, M.B., Brooks-Gunn, J., Bingenheimer, J.B., & Earls, F.J. (2004). The homelife interview from the project on human development in Chicago neighborhoods: Assessment of parenting and home environment for 3- to 15-year-olds. *Parenting: Science & Practice, 4*, 211-241.
- Loeber, R., & Stouthamer-Loeber, M. (1986). Economic hardship, parenting, and distress in adolescence. *Child Development, 60*, 25-39.

- Loeber, R. & Stouthamer-Loeber, M. (1998). Development of juvenile aggression and violence: Some common misconceptions and controversies. *American Psychologist*, *53*, 242-259.
- Lonigan, C.J., Vasey, M.W., Phillips, B.M., & Hazen, R.A. (2004). Temperament, anxiety, and the processing of threat-relevant stimuli. *Journal of Clinical Child and Adolescent Psychology*, *33*, 8-20.
- Maccoby, E.E. (1992). The role of parents in the socialization of children: An historical overview. *Developmental Psychology*, *28*, 1006-1017.
- Malatesta, C.Z. & Haviland, J.M. (1986). Measuring change in infant emotional expressivity: Two approaches applied in longitudinal investigation. In C.E. Izard & P.B. Read (Eds.), *Measuring emotions in infants and children: Vol. 2. Cambridge studies in social and emotional development* (pp. 51-74). Cambridge, England: Cambridge University Press.
- Mangelsdorf, S., Gunnar, M., Kestenbaum, R., Lang, S., & Andreas, D. (1990). Infant proneness-to-distress temperament, maternal personality, and mother-infant attachment: Associations and goodness of fit. *Child Development*, *61*, 820-831.
- Maziade, M., Caron, C., Cote, R., Merette, C., Bernier, H., Laplante, B., Boutin, P., & Thivierge, J. (1990). Psychiatric status of adolescents who had extreme temperaments at age 7. *American Journal of Psychiatry*, *147*, 1531-1536.
- McClelland, G. H., & Judd, C. M. (1993). Statistical difficulties of detecting interactions and moderator effects. *Psychological Bulletin*, *114*, 376-390.
- Moffitt, T.E. (1993). Adolescence-limited and life-course-persistent antisocial behavior: A developmental taxonomy. *Psychological Review*, *100*, 674-701.
- Moffitt, T.E. (2003). Life-course-persistent and adolescence-limited antisocial behavior: A 10-year research review and a research agenda. In L. Benjamin B., T.E. Moffitt, & A. Caspi, (Eds.), *Causes of Conduct Disorder and Juvenile Delinquency* (pp. 49-75). New York, NY, US: Guilford Press.
- Moffitt, T.E., Caspi, A., Harrington, H., & Milne, B.J. (2002). Males on the life-course-persistent and adolescence-limited antisocial pathways: Follow-up at ages 26 years. *Development and Psychopathology*, *14*, 179-207.
- Mullineaux, P.Y., Deater-Deckard, K., Petrill, S.A., Thompson, L.A. (2009). Parenting and child behaviour problems: A longitudinal analysis of non-shared environment. *Infant and Child Development*, *18*, 133-148.
- Mun, E.Y., Fitzgerald, H.E., Von Eye, A., Puttler, L.I., & Zucker, R.A. (2001). Temperament characteristics as predictors of externalizing and internalizing child behavior problems in the contexts of high and low parental psychopathology. *Infant Mental Health Journal*, *22*, 393-415.
- Muris, P., Meesters, C., & Blijlevens, P. (2007). Self-reported reactive and regulative temperament in early adolescence: relations to internalizing and externalizing problem behavior and "Big Three" personality factors. *Journal of Adolescence*, *30*, 1035-1049.

- Muris, P. & Ollendick, T.H. (2005). The role of temperament in the etiology of child psychopathology. *Clinical Child and Family Psychology Review*, 8, 271-289.
- Muthén, L.K. & Muthén, B.O. (2001). Mplus statistical analysis with latent variables. User's guide. Los Angeles, CA.
- Nagin, D. & Tremblay, R.E. (1999). Trajectories of boys' physical aggression, opposition, and hyperactivity on the path to physically violent and non violent juvenile delinquency. *Child Development*, 70, 71-85.
- Nagin, D. & Tremblay, R.E. (2001). Developmental trajectories of physical aggression from school entry to late adolescence. *Journal of Child Psychology and Psychiatry*, 42, 503-512.
- Najman, J.M., Williams, G.M., Nikles, J., Spence, S., Bor, W., O'Callaghan, M., Le Brocque, R., Andersen, M.J., & Shuttlewood, J. (2001). Bias influencing maternal reports of child behaviour and emotional state. *Social Psychiatry and Psychiatric Epidemiology*, 36, 186-194.
- National Institute of Child Health and Human Development Early Child Care Research Network. (2004). Fathers' and mothers' parenting behavior and beliefs as predictors of children's social adjustment in the transition to school. *Journal of Family Psychology*, 18, 628-638.
- Nigg, J.T. (2006). Temperament and developmental psychopathology. *Journal of Child Psychology and Psychiatry*, 47, 395-422.
- Nigg, J.T., Goldsmith, H.H., & Sachek, J. (2004). Temperament and attention deficit hyperactivity disorder: The development of a multiple pathway model. *Journal of Clinical Child and Adolescent Psychology*, 33, 42-53.
- Oldehinkel, A.J., Hartman, C.A., de Winter, A.F., Veenstra, R., & Ormel, J. (2004). Temperament profiles associated with internalizing and externalizing problems in preadolescence. *Development and Psychopathology*, 16, 421-440.
- Olson, S.L., Sameroff, A.J., Kerr, D.C.R., Lopez, N.L., & Wellman, H. M. (2005). Developmental foundations of externalizing problems in young children: The role of effortful control. *Development and Psychopathology*, 17, 25-45.
- Ormel, A.J., Oldehinkel, A.J., Ferdinand, R.F., Hartman, C.A., de Winter, A.F., & Veenstra, R. (2005). Internalizing and externalizing problems in adolescence: general and dimension specific effects of familial loadings and preadolescent temperament traits. *Psychological Medicine*, 35, 1825-1835.
- Patrick, C.J., Curtin, J.J., & Tellegen, A. (2002). Development and validation of a brief form of the Multidimensional Personality Questionnaire. *Psychological Assessment*, 14, 150-163.
- Patterson, G. R. (1982). *A Social Learning Approach: Vol. 3: Coercive family process*. Eugene, OR: Castalia.
- Patterson, G.R. (1986). Performance models for antisocial boys. *American Psychologist*, 41, 432-444.

- Patterson, G. R., Degarmo, D.S., & Knutson, N. (2000). Hyperactive and antisocial behaviors: Comorbid or two points in the same process? *Development and Psychopathology, 12*, 91-106.
- Patterson, G., DeBaryshe, B., & Ramsey, E. (1989). A developmental perspective on antisocial behavior. *American Psychologist, 44*, 329-335.
- Patterson, G.R., Reid, J.B., & Dishion, T.J. (1992). *A social learning approach. IV. Antisocial boys*. Eugene, OR: Castalia.
- Pedlow, R., Sanson, A., Prior, M., & Oberklaid, F. (1993). Stability of maternally reported temperament from infancy to 8 years. *Developmental Psychology, 29*, 998-1007.
- Petterson, L., Ewigman, B., & Kivlahan, C. (1993). Judgments regarding appropriate child supervision to prevent injury: The role of environmental risk and child age. *Child Development, 64*, 934-950.
- Pfiffner, L.J., McBurnett, K., Rathouz, P.J., & Judice, S. (2005). Family correlates of oppositional and conduct disorders in children with attention deficit/hyperactivity disorder. *Journal of Abnormal Child Psychology, 33*, 551-563.
- Phares, V. (1997). Accuracy of informants: Do parents think that mother knows best? *Journal of Abnormal Child Psychology, 25*, 165-171.
- Price, J.S., Gardner, R., Gilbert, P., & Rhode, P. (1994). The social competition hypothesis of depression. *British Journal of Psychiatry, 164*, 309-315.
- Prior, M. (1992). Childhood temperament. *Journal of Child Psychology and Psychiatry, 33*, 249-279.
- Ramos, M.C., Guerin, D.W., Gottfried, A.W., Bathurst, K., & Oliver, P.H. (2005). Family conflict and children's behavior problems: the moderating role of child temperament. *Structural Equation Modeling, 12*, 278-298.
- Reid, J.B., Patterson, G.R., & Snyder, J.J. (Eds.). (2002). *Antisocial behavior in children and adolescents: A developmental analysis and the Oregon Model for Intervention*. Washington, DC: American Psychological Association.
- Reid, J.B., Taplin, P.S., & Lorber, R. (1981). A social interactional approach to the treatment of abusive families. In R.B. Stuart (Ed.), *Violent behavior social learning approaches to proneness, management, and treatment*. New York: Brunner/Mazel.
- Rothbart, M.K. (2004). Commentary: Differentiated measures of temperament and multiple pathways to childhood disorders. *Journal of Clinical Child and Adolescent Psychology, 33*, 82-87.
- Rothbart, M.K. (2007). Temperament, development, and personality. *Current Directions in Psychological Science, 16*, 207-212.
- Rothbart, M.K. & Ahadi, S.A. (1994). Temperament and the development of personality. *Journal of Abnormal Psychology, 103*, 55-66.

- Rothbart, M.K., Ahadi, S.A., & Hershey, K.L. (1994). Temperament and social behavior in childhood. *Merrill-Palmer Quarterly*, *40*, 21-39.
- Rothbart, M. K., Ahadi, S.A., Hershey, K.L. & Fisher, P. (2001). Investigations of temperament at three to seven years: the children's behavior questionnaire. *Child Development*, *72*, 1394-1408.
- Rothbart M.K. & Bates, J.E. (1998). Temperament. In W. Damon, R. Lerner, & N. Eisenberg (Eds.), *Handbook of child psychology: Vol. 3. Social, Emotional, and Personality Development* (6<sup>th</sup> ed., pp. 105-176). New York: Wiley.
- Rothbart M.K. & Bates, J.E. (2006). Temperament. In N. Eisenberg, W. Damon, R. Lerner, & (Eds.), *Handbook of child psychology: Vol. 3. Social, Emotional, and Personality Development* (6<sup>th</sup> ed., pp. 99-166). New York: Wiley.
- Rothbart, M.K. & Derryberry, D. (1981). Development of individual differences in temperament. In M.E. Lambh & A. Brown (Eds.), *Advances in developmental psychology* (Vol. 1, pp. 99-166). New York: Wiley.
- Rothbart, M.K., Derryberry, D., & Posner, M.I. (1994). A psychobiological approach to the development of temperament. J.E. Bates & T.D. Wachs (Eds.), *Temperament: Individual differences at the interface of biology and behavior*. (pp. 83-116). APA science volumes. Washington, DC, US: American Psychological Association.
- Rothbart, M.K., & Putnam, S.P. (2002). Temperament and socialization. In L. Pulkinnen & A. Caspi (Eds.), *Paths to successful development: Personality in the life course*: (pp.19-45). Cambridge, UK: Cambridge University Press.
- Rothbaum, F. & Weisz, J.R. (1994). Parental caregiving and child externalizing behavior in nonclinical samples: A meta-analysis. *Psychological Bulletin*, *116*, 55-74.
- Rubin, K.H., Burgess, K.B., Dwyer, K.M., & Hastings, P.D. (2003). Predicting preschoolers' externalizing behaviors from toddler temperament, conflict, and maternal negativity. *Developmental Psychology*, *39*, 164-176.
- Ruschena, E., Prior, M., Sanson, A., Smart, D. (2005). A longitudinal study of adolescent adjustment following family transitions. *Journal of Child Psychology and Psychiatry*, *46*, 353-363.
- Salmivalli, C., Kaukiainen, A., & Lagerspetz, K. (2000). Aggression and sociometric status among peers: Do gender and type of aggression matter. *Scandinavian Journal of Psychology*, *41*, 17-24.
- Sanson, A., Hemphill, S.A., & Smart, D. (2004). Connections between temperament and social development: a review. *Social Development*, *13*, 142-170.
- Sanson, A., Prior, M. (1999). Temperament and behavioral precursors to oppositional defiant disorder and conduct disorder. In H.C. Quay & A.E. Hogan (Eds.), *Handbook of Disruptive Behavior Disorders* (pp. 397-417). Dordrecht, Netherlands: Kluwer Academic Publishers.
- Sanson, A., Prior, M., & Kyrios, M. (1990). Contamination of measures in temperament research. *Merrill-Palmer Quarterly*, *36*, 179-192.

- Santiago, C.D., Wadsworth, M.E., & Stump, J. (2011). Socioeconomic status, neighborhood disadvantage, and poverty-related stress: Prospective effects on psychological syndromes among diverse low-income families. *Journal of Economic Psychology, 32*, 218-230.
- Seguin, J.R., Boulerice, B., Harden, P., Tremblay, R.E., & Pihl, R.O. (1999). Executive functions and physical aggression after controlling for attention deficit hyperactivity disorder, general memory, and IQ. *Journal of Child Psychology and Psychiatry, 40*, 1197-1208.
- Selner, M.E. (1992). *The role of childhood sensation seeking and parental supervision in the emergence of childhood psychopathology*. Unpublished doctoral dissertation, University of Iowa, Iowa City.
- Selner, M.E. & Knutson, J.F. (1990, May 3). *The development of the Children's Experience and Excitement Scale*. Paper presented at the Midwestern Psychological Association Meeting, Chicago.
- Shaw, D.S., Bell, R.Q., & Gilliom, M. (2000). A truly early starter model of antisocial behavior revisited. *Clinical Child and Family Psychology Review, 3*, 155-172.
- Shaw, D.S., Keenan, K., & Vondra, J.I. (1994). Developmental precursors of externalizing behavior: Ages 1 to 3. *Developmental Psychology, 39*, 355-364.
- Shiner, R. & Caspi, A. (2003). Personality differences in childhood and adolescence: Measurement, development, and consequences. *Journal of Child Psychology and Psychiatry, 44*, 2-32.
- Simons, D.A., & Wurtele, S.K. (2010). Relationship between parents' use of corporal punishment and their children's endorsement of spanking and hitting other children. *Child Abuse & Neglect, 34*, 639-646.
- Sines, J.O., Clarke, W.M., & Lauer, R.M. (1984). Home Environment Questionnaire. *Journal of Abnormal Child Psychology, 12*, 519-529.
- Smiley, P.A. & Dweck, C.S. (1994). Individual differences in achievement goals among young children. *Child Development, 65*, 1723-1743.
- Snyder, J., Cramer, A., Afrank, J., & Patterson, G.R. (2005). The contributions of ineffective discipline and parental hostile attributions of child misbehavior to the development of conduct problems at home and school. *Developmental Psychology, 41*, 30-41.
- Steiger, J.H., & Lind, J.C. (1980). Statistically-based tests for the number of common factors. *Paper presented at the annual spring meeting of the psychometric society in Iowa city*. May 30, 1980.
- Sternberg, K.J., Knutson, J.F., Lamb, M.E., Bradaran, L.P., Nolan, C., & Flanzer, S. (2004). The Child Maltreatment Log: A PC-based program for describing research samples. *Child Maltreatment, 9*, 30-48.

- Stormshak, E.A., Bierman, K.L., McMahon, R.J., Lengua, L., & Conduct Problems Prevention Research Group. (2000). Parenting practices and child disruptive problems in early elementary school. *Journal of Clinical Child Psychology, 29*, 17-29.
- Straus, M. A., & Stewart, J. H. (1999). Corporal punishment by American parents: National data on prevalence, chronicity, severity, and duration, in relation to child and family characteristics. *Clinical Child and Family Psychology Review, 2*, 55–70.
- Stright, A.D., Gallagher, K.C., & Kelley, K. (2008). Infant temperament moderates relations between maternal parenting in early childhood and children's adjustment in first grade. *Child Development, 79*, 186-200.
- Stroop, J.R. (1935). Studies of interference in serial verbal reactions. *Journal of Experimental Psychology, 18*, 643-662.
- Suskauer, S.J., Simmonds, D.J., Fotedar, S., Blankner, J.G., Pekar, J.J., Denckla, M.B., & Mostofsky, S.H. (2008). Functional magnetic resonance imaging evidence for abnormalities in response selection in attention deficit hyperactivity disorder: Differences in activation associated with response inhibition but not habitual motor response. *Journal of Cognitive Neuroscience, 20*, 478-493.
- Taber, S.M. (2010). The veridicality of children's reports of parenting: A review of factors that contribute to parent-child discrepancies. *Clinical Psychology Review, 30*, 999-110.
- Tellegen, A. (1982). *Brief manual for the Multidimensional Personality Questionnaire*. Unpublished manuscript, University of Minnesota, Minneapolis.
- Tellegen, A. (1985). Structures of mood and personality and their relevance to assessing anxiety, with an emphasis on self-report. In A. H. Tuma & J. D. Maser (Eds.), *Anxiety and the anxiety disorders* (pp. 681–706). Hillsdale, NJ: Erlbaum.
- Tellegen, A. (in press). *Manual for the Multidimensional Personality Questionnaire*. Unpublished manuscript, University of Minnesota, Minneapolis.
- Thomas, A. & Chess, S. (1977). *Temperament and development*. Oxford, England: Brunner/Mazel.
- Tremblay, R. (2000). The development of aggressive behavior during childhood: what have we learned in the past century? *International Journal of Behavioral Development, 24*, 129-141.
- Tucker, L. R., & Lewis, C. (1973). A reliability coefficient for maximum likelihood factor analysis. *Psychometrika, 38*, 1-10.
- Tymchuk, A.J., Lang, C.M., Dolyniuk, C.A., Berney-Ficklin, K., & Spitz, R. (1999). The Home Inventory of Dangers and Safety Precautions-2: Addressing critical needs for prescriptive assessment devices in child maltreatment and in healthcare. *Child Abuse and Neglect, 23*, 1-14.
- Valles, N. & Knutson, J.F. (2008). Contingent responses of mothers and peers to indirect and direct aggression in preschool and school-aged children. *Aggressive Behavior, 34*, 497-510.

- van Aken, C., Junger, M., Verhoeven, M., van Aken, M.A.G., & Dekovic, M. (2007). The interactive effects of temperament and maternal parenting on toddlers' externalizing behaviors. *Infant and Child Development, 16*, 553-572.
- Vitaro, F., Barker, E.D., Boivin, M., Brendgen, M., & Tremblay, R.E. (2006). Do early difficult temperament and harsh parenting differentially predict reactive and proactive aggression? *Journal of Abnormal Child Psychology, 34*, 685-695.
- Wahler, I.L.G., & Dumas, J.E. (1986). Maintenance factors in coercive mother-child interactions: The compliance and predictability hypothesis. *Journal of Applied Behavior Analysis, 19*, 13-22.
- Watson, D., Clark, L.A., & Chmielewski, M. (2008). Structures of personality and their relevance to psychopathology: II. Further articulation of a comprehensive unified trait structure. *Journal of Personality, 76*, 1545-1585.
- Whipple, E.E., & Richey, C.A. (1997). Crossing the line from physical discipline to child abuse: How much is too much? *Child Abuse and Neglect, 21*, 431-444.
- Wolfe, C.D. & Bell, M.A. (2007). Sources of variability in working memory in early childhood: A consideration of age, temperament, language, and brain electrical activity. *Cognitive Development, 22*, 431-455.
- Zahn-Waxler, C., Iannotti, R.J., Cummings, E.M., & Denham, S.A. (1990). Antecedents of problem behaviors in children of depressed mothers. *Development and Psychopathology, 2*, 271-291.
- Zaidi, L.Y., Knutson, J.F., Mehm, J.G. (1989). Transgenerational patterns of abusive parenting: analog and clinical tests. *Aggressive Behavior, 15*, 137-152.
- Zisser, A. & Eyberg, S.M. (2010). Parent-Child Interaction Therapy and the treatment of disruptive behavior disorders. In J.R. Weisz & A.E. Kazdin (Eds.), *Evidence-based psychotherapies for children and adolescents* (pp. 179-193). 2<sup>nd</sup> ed. New York: Guilford Publications.