



US006456886B1

(12) **United States Patent**
Howard, III et al.

(10) **Patent No.:** **US 6,456,886 B1**
(45) **Date of Patent:** ***Sep. 24, 2002**

(54) **HUMAN CEREBAL CORTEX NEURAL PROSTHETIC FOR TINNITUS**

FOREIGN PATENT DOCUMENTS

(75) Inventors: **Matthew A. Howard, III; Timothy A McCulloch**, both of Iowa City, IA (US); **Carol A. Bauer**, Houston, TX (US)

AU	0 124 930	11/1984
EP	0158397	10/1985
EP	0259906	3/1988

(73) Assignee: **University of Iowa Research Foundation**, Iowa City, IA (US)

OTHER PUBLICATIONS

(*) Notice: This patent issued on a continued prosecution application filed under 37 CFR 1.53(d), and is subject to the twenty year patent term provisions of 35 U.S.C. 154(a)(2).

Ifukube, T. et al, "Design of an Implantable Tinnitus Suppressor By Electrical Cochlear Stimulation", *Biomechanics, Rehabilitation, Electrical Phenomena, Biomaterials*, Oct. 28-31, 1993, pp 1349-1350.

Subject to any disclaimer, the term of this patent is extended or adjusted under 35 U.S.C. 154(b) by 0 days.

Dobelle, W.H. et al., "A Prosthesis for the Deaf Based on Cortical Stimulation", *Annals of Otology, Rhinology and Laryngology*, vol. 82, 1973, pp 445-463.

This patent is subject to a terminal disclaimer.

(List continued on next page.)

(21) Appl. No.: **08/869,947**

Primary Examiner—David Isabella

(22) Filed: **Jun. 5, 1997**

(74) *Attorney, Agent, or Firm*—Fleshner & Kim, LLP

Related U.S. Application Data

(57) **ABSTRACT**

(63) Continuation of application No. 08/332,755, filed on Nov. 1, 1994, now Pat. No. 5,697,975, which is a continuation-in-part of application No. 08/194,017, filed on Feb. 9, 1994, now Pat. No. 5,496,369.

A neural prosthetic device for reducing or eliminating the effects of tinnitus is inserted into a tinnitus patient's primary auditory cortex (or thalamus). The prosthetic device includes a stimulation device for outputting processed electrical signals and an electrode arranged in the primary auditory cortex having a plurality of electrical contacts. Each of the plurality of electrical contacts independently outputs electrical discharges in accordance with the electrical signals. In another embodiment, a catheter is inserted into the tinnitus patient's primary auditory cortex or thalamus. The catheter microinfuses drugs which suppress or eliminate abnormal neural activity into disperse geometric locations in the cortex or thalamus, thereby reducing or eliminating the effects of the patient's tinnitus.

(51) **Int. Cl.**⁷ **A61M 1/08; A61F 2/18**
(52) **U.S. Cl.** **607/55; 607/57; 623/10**
(58) **Field of Search** **600/25; 607/2, 607/55, 56, 57; 623/10, 11, 24, 66**

(56) **References Cited**

U.S. PATENT DOCUMENTS

3,147,750 A	9/1964	Fry	128/2.1
4,245,645 A	1/1981	Arseneault et al.	
4,357,497 A	* 11/1982	Hochmair et al.	607/57

(List continued on next page.)

21 Claims, 12 Drawing Sheets

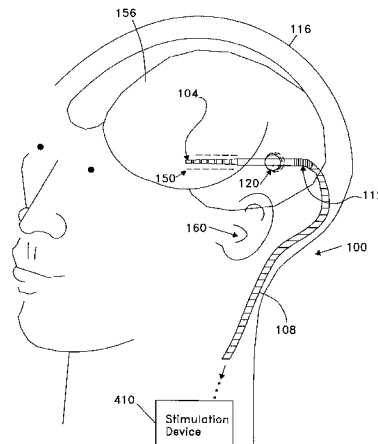

U.S. PATENT DOCUMENTS

4,360,019	A	11/1982	Portner et al.	128/213	R
4,461,304	A	7/1984	Kuperstein	128/642	
4,490,137	A	12/1984	Moukheibir	604/28	
4,522,212	A	6/1985	Gelinas et al.		
4,646,744	A	3/1987	Capel	128/423	R
4,735,968	A	4/1988	Guth	514/561	
4,762,135	A	8/1988	Van Der Puije et al.	128/784	
4,850,359	A	7/1989	Putz	128/642	
4,892,102	A	1/1990	Astrinsky	128/642	
4,907,589	A	3/1990	Cosman	606/34	
4,968,306	A	11/1990	Huss et al.		
4,969,468	A	11/1990	Byers et al.	128/642	
5,000,194	A	3/1991	van den Honert et al. ..	128/784	
5,053,002	A	10/1991	Barlow		
5,084,007	A	1/1992	Malin et al.	604/20	
5,099,846	A	3/1992	Hardy	128/653.1	
5,119,832	A	6/1992	Xavier	128/786	
5,176,652	A	1/1993	Littrell	604/167	
5,188,104	A	2/1993	Wernicke et al.	128/419	R
5,221,283	A	6/1993	Chang	606/130	
5,250,033	A	10/1993	Evans et al.	604/160	
5,254,105	A	10/1993	Haaga	604/265	
5,262,178	A	11/1993	Malfroy		
			Camine et al.	424/94.67	
5,263,480	A	11/1993	Wernicke et al.	607/118	
5,271,397	A	12/1993	Segliman et al.	607/10	
5,328,460	A	7/1994	Lord et al.	604/67	
5,332,401	A	7/1994	Davey et al.	607/116	
5,341,807	A	8/1994	Nardella	128/642	
5,380,288	A	1/1995	Hart et al.	604/167	
5,385,146	A	1/1995	Goldreyer	128/642	
5,385,560	A	1/1995	Wulf	604/264	
5,389,101	A	2/1995	Heilbrun et al.	606/130	
5,405,375	A	4/1995	Ayers et al.	604/122	
5,429,131	A	7/1995	Scheinman et al.		
5,429,582	A	7/1995	Williams	600/2	
5,443,710	A	8/1995	Broderick	204/403	
5,462,544	A	10/1995	Saksena et al.	606/15	
5,496,369	A	* 3/1996	Howard, III	623/11	X
5,531,759	A	7/1996	Kensey et al.	606/213	
5,540,734	A	7/1996	Zabara	607/46	
5,545,193	A	8/1996	Fleischman	607/99	
5,545,200	A	8/1996	West et al.	607/122	
5,545,201	A	8/1996	Helland	607/127	
5,545,219	A	8/1996	Kuzma	623/10	
5,582,609	A	12/1996	Swanson et al.	606/39	
5,584,847	A	12/1996	Duloco et al.	606/185	
5,697,975	A	* 12/1997	Howard, III et al.	623/10	
5,843,093	A	* 12/1998	Howard, III	600/378	

OTHER PUBLICATIONS

Brindley, G.S. et al., The Sensations Produced by Electrical Stimulation of the Visual Cortex, *J. Physiol.* 196:479-493 (1968).

Damasio et al., Three-dimensional In Vivo Mapping of Brain Lesions in Humans, *Arch. Neurol* 49:137-143 (Feb. 1992).

Drake, K.L., et al. :Performance of Planar Multisite Microprobes in Recording Extracellular Single-Unit Intracortical Activity, *IEEE Trans. BME* 35-719-732 (1988).

Hitselberger, W.e. et al., :Cochlear Nucleus Implant, *Otolaryngology head neck-Surg.* 92:52-54 (1984).

Martuza, R.L. et al., Neurofibromatosis 2 (Bilateral Acoustic Neurofibromatosis), *N. Engl., J. Med.* 318: 684-688 (1988).

Penfield, W. et al., *Epilepsy and the Functional Anatomy of the Human Brain*, Little, Brown and Company, Boston, (1954).

Dieckman G, Schneider H. "Influence of Stereotactic Hypothalamotomy on Alcohol and Drug Addiction." *Appl. Neurophysiol.* 41:93-98,1978.

Mayanagi Y, Hori T, Sano K. "The Posteromedial Hypothalamus and Pain, Behavior, with Special Reference to Endocrinological Findings." *Appl. Neurophysiol* 41:223-231, 1978.

Nakao H. "Emotional behavior produced by hypothalamic stimulation", *Am J Physiol* 194:411-418, 1958.

Sano K. "Effects of Stimulation and Destruction of the Posterior Hypothalamus in Cases of Behaviour Disorders and Epilepsy." Special topics in stereotaxis, Berlin Symposium 1970. Hippokrates Verlag Stuttgart.

Bielajew C, Stenger J, Schindler D. "Factors that contribute to the reduced weight gain following chronic ventromedial hypothalamic stimulation." *Behavioral Brain Research* 62:143-148, 1994.

Stenger J, Fournier T, Bielajew C. "The Effects of Chronic Ventromedial Hypothalamic Stimulation on Weight Gain in Rats." *Physiol. Behav.* 50:1209-1213, 1991.

Cohen et al., "A Prospective, Randomized Study of Cochlear Implants," *N.E. J. of Med.*, vol. 328, No. 4, Jan. 1993, pp. 233-237.

Eisenberg et al., "Electrical Stimulation of the Auditory Brain Stem Structure in Deafened Adults," *J. Rehab. Research*, vol. 24, No. 3, 1987, pp. 9-22.

Center for Integrated Sensors and Circuits, "Passive Multichannel Recording and Stimulating Electrode Arrays: A Catalog of Available Designs", Jul. 1991.

Medtronic, The ITREL® II, The third generation of excellence, (1991).

Eggermount, "Neural Interaction in Cat Primary Auditory Cortex," 10/92; pp 1216-1228 *J. of Neurophysiology*, vol. 68, No. 4.

Bak, M. et al., Visual Sensations produced by Intracortical Microstimulation of the Human Occipital Cortex, *Med. Biol. Eng. Comput.*, 28:257-259 (1990).

James P. Morgan, "The First Reported Case of Electrical Stimulation of the Human Brain," *J. Hist. Med.*, Jan., 1982, pp. 51-63.

A. Earl Walker, "The Development of the Concept of Cerebral Localization in the Nineteenth Century," *Bulletin His. Med.*, vol. 31, No. 2, Mar.-Apr., 1957, pp. 99-121.

Penfield et al., "Somatic Motor and Sensory Representation in the Cerebral Cortex of Man as Studied by Electrical Stimulation," *Brain*, vol. 60, 1937, pp. 389-443.

Penfield et al., "The Brain's Record of Auditory and Visual Experience," *Brain*, vol. 86, Dec. 1963, pp. 596-696.

Dobelle et al., "Artificial Vision for the Blind: Electrical Stimulation of Visual Cortex Offers Hope for a Functional Prosthesis," *Science*, vol. 183, 1974, pp. 440-444.

Dobelle et al., "A Prosthesis for the Deaf Based on Cortical Stimulation," *Ann. Otol.*, vol. 82, 1973, pp. 445-463.

* cited by examiner

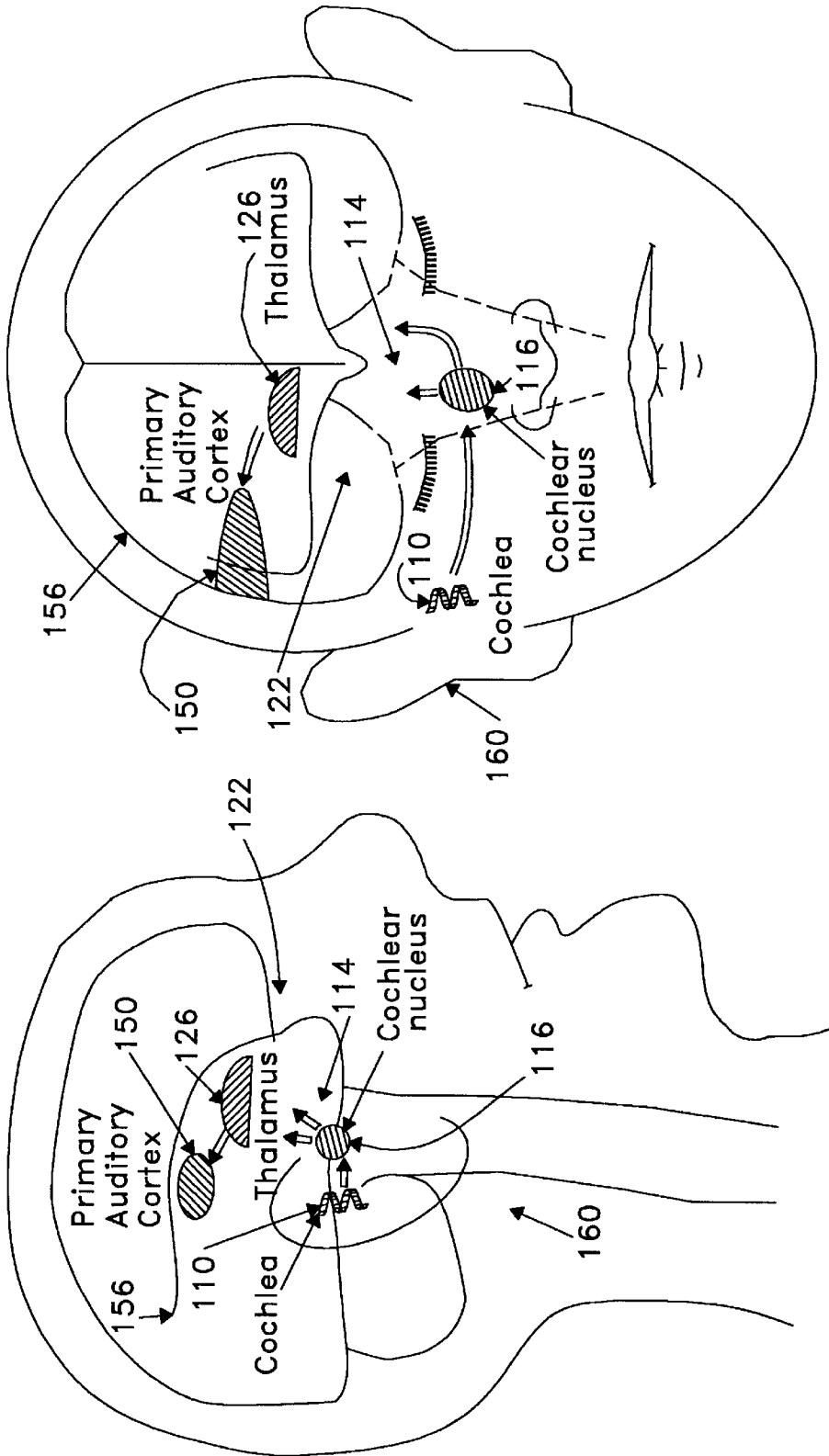

FIG. 1B

FIG. 1A

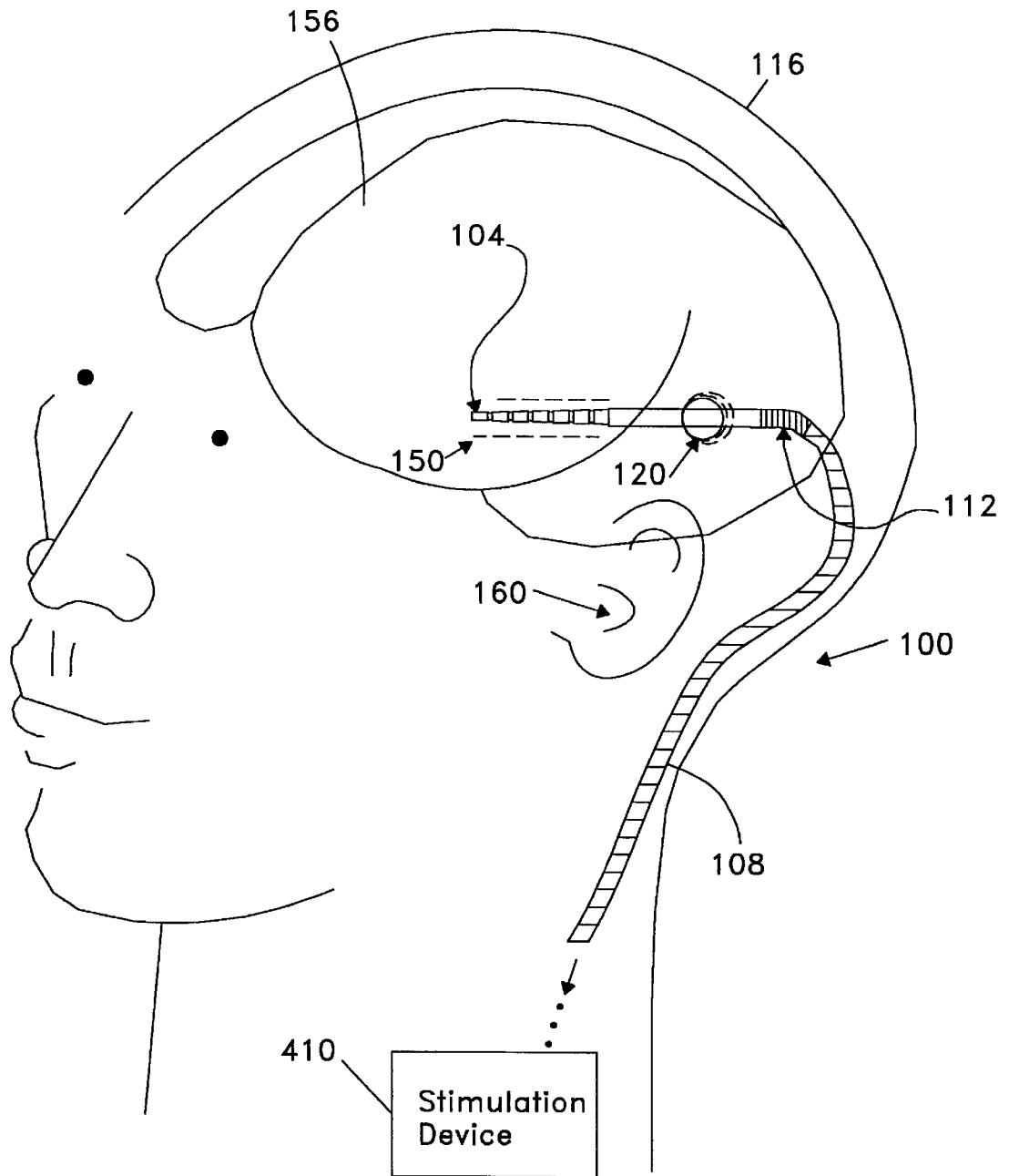

FIG. 2A

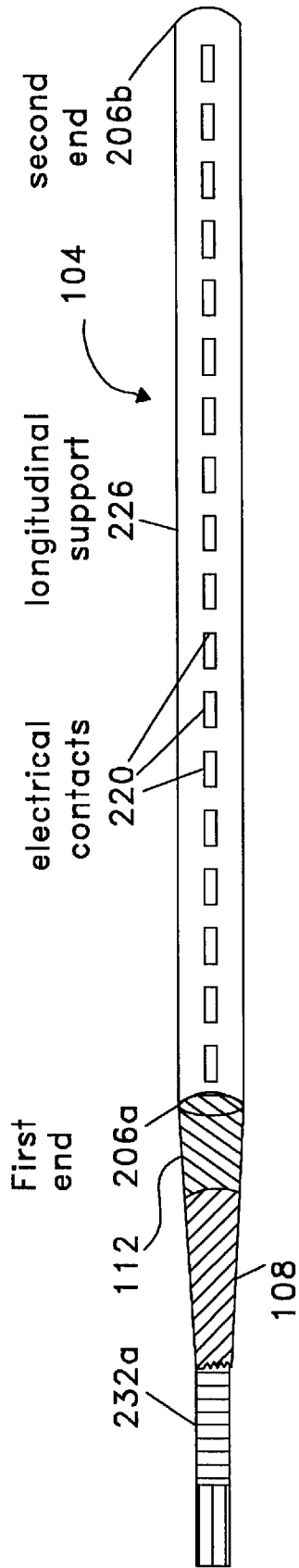

FIG. 2B

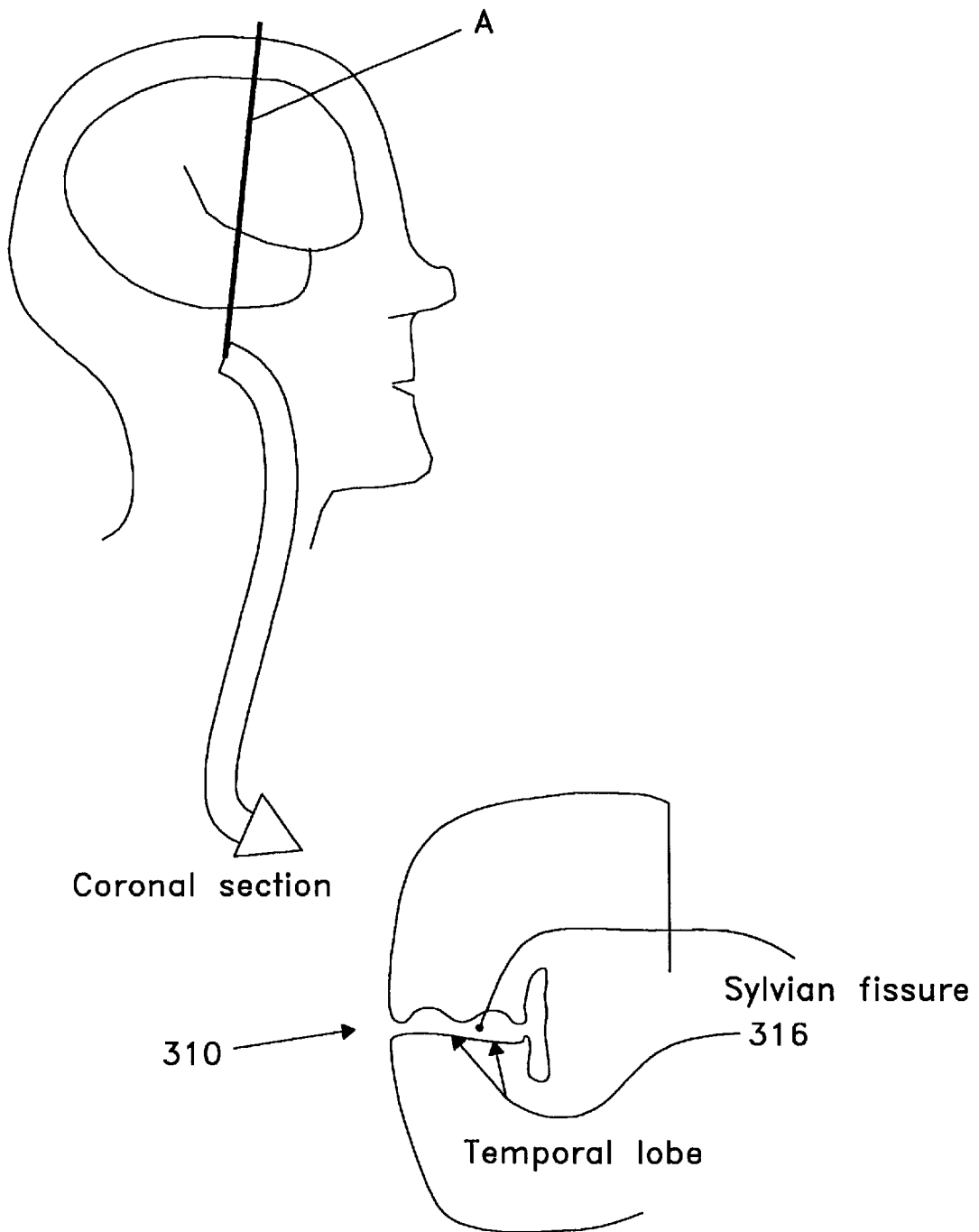

FIG. 3A

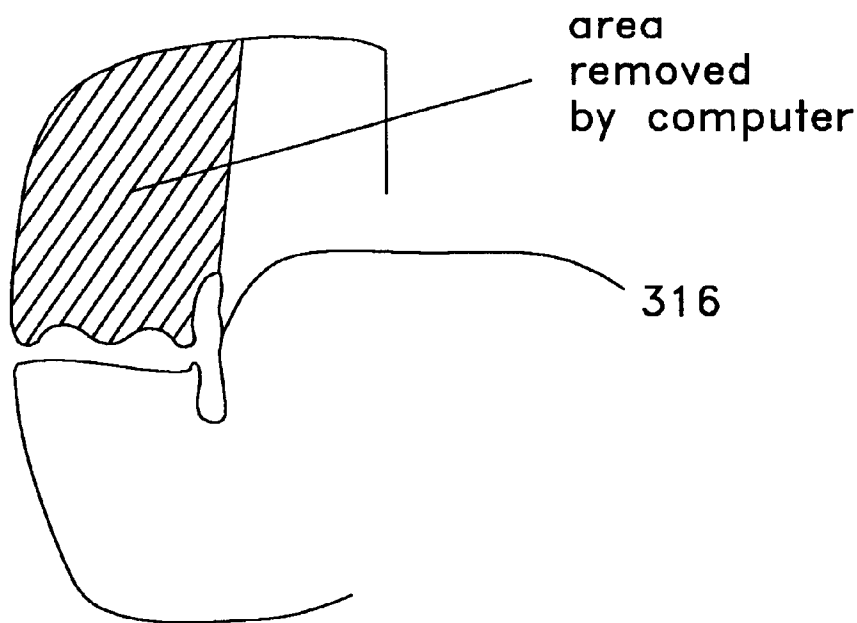

FIG. 3B

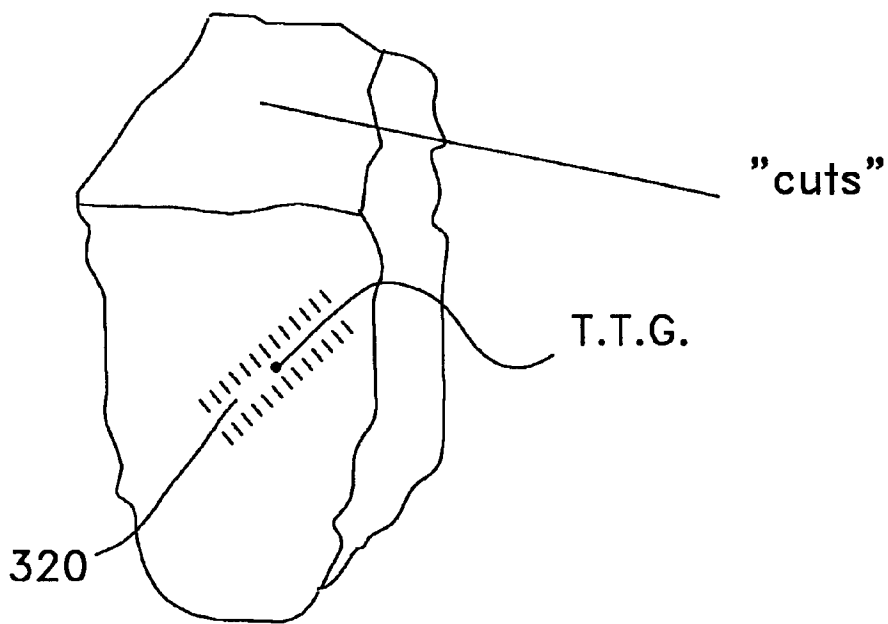

FIG. 3C

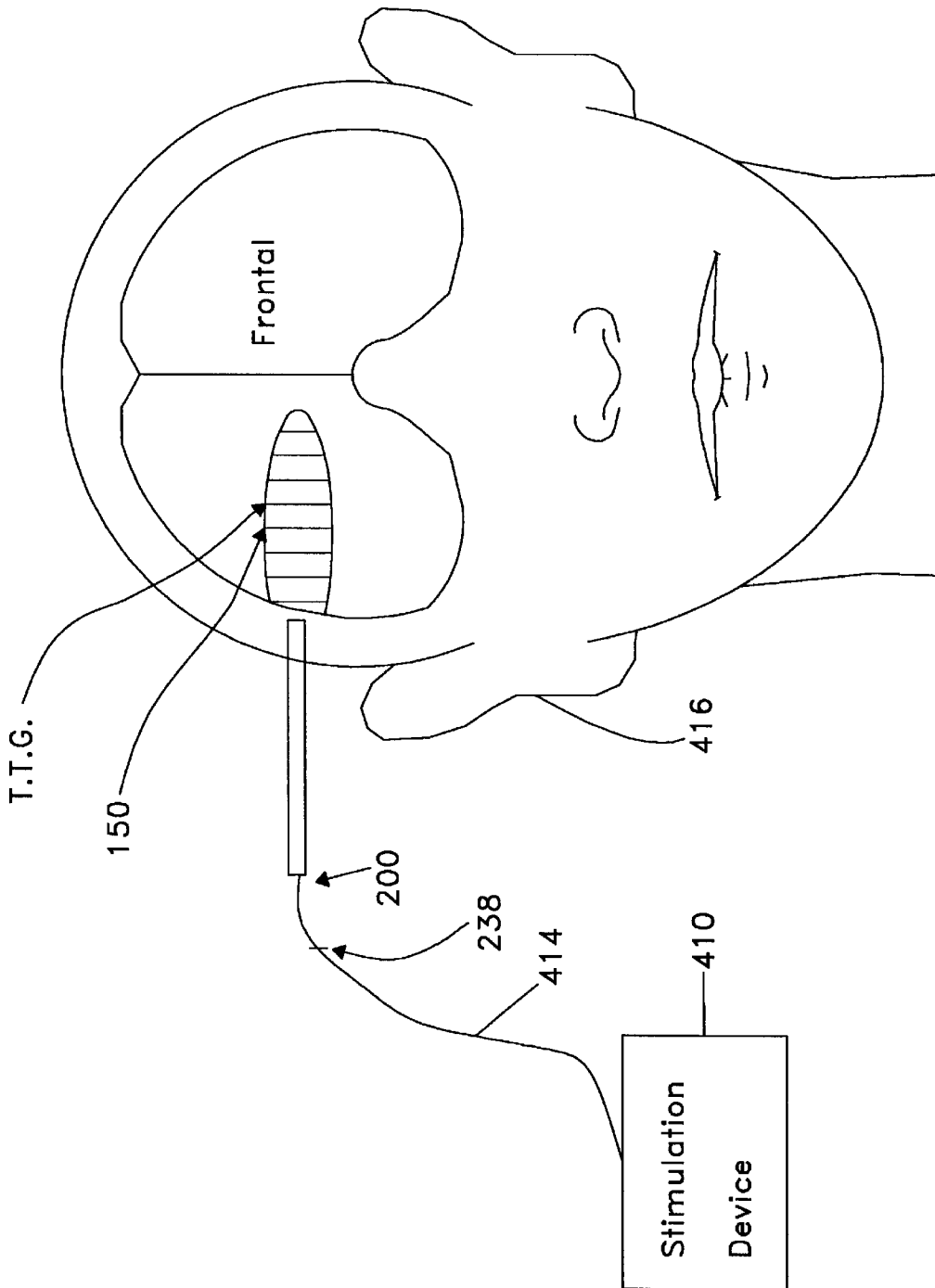

FIG. 4

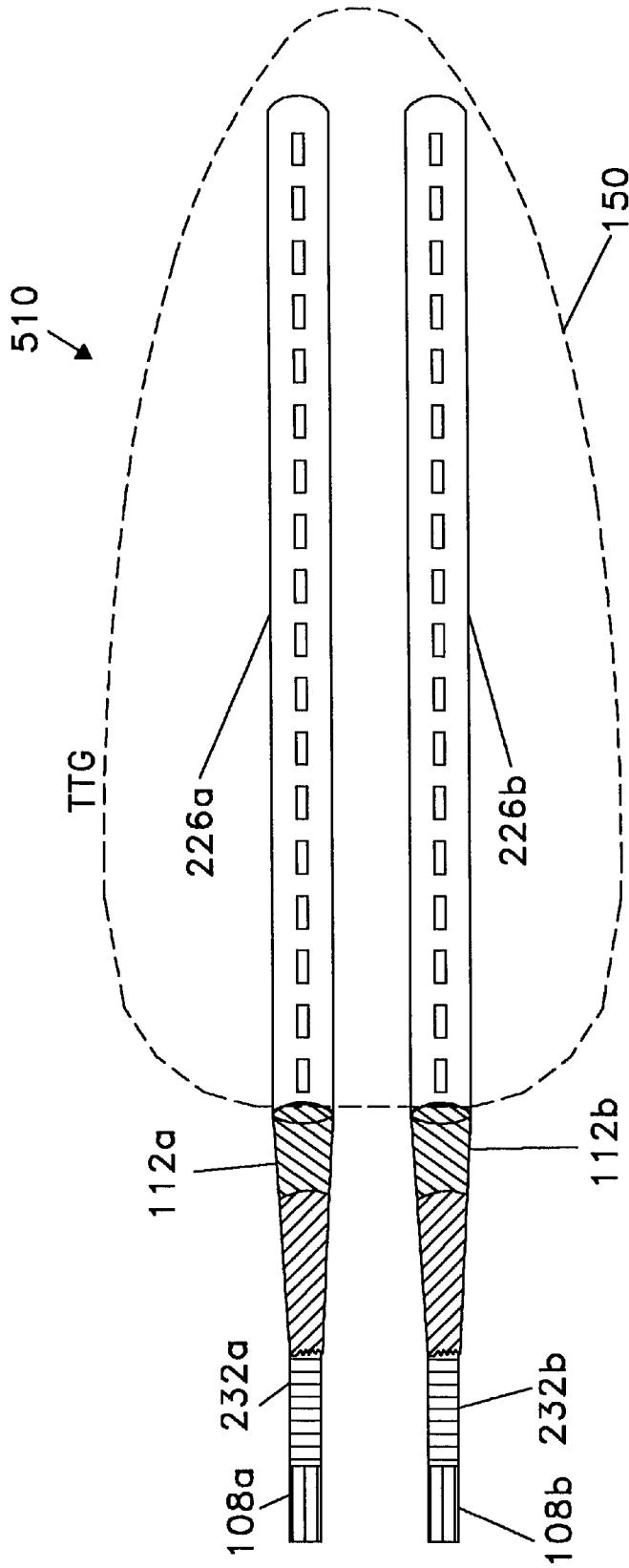

FIG. 5

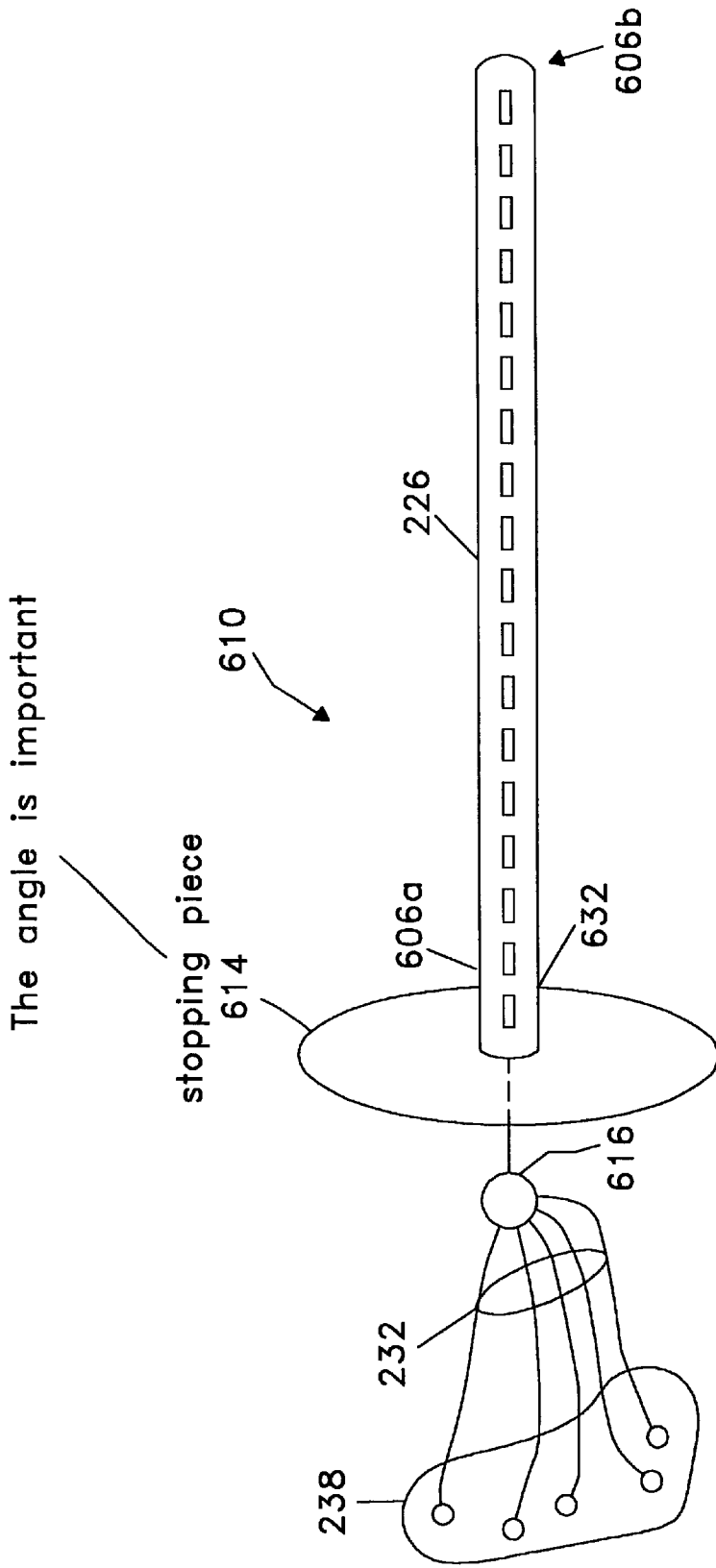

FIG. 6

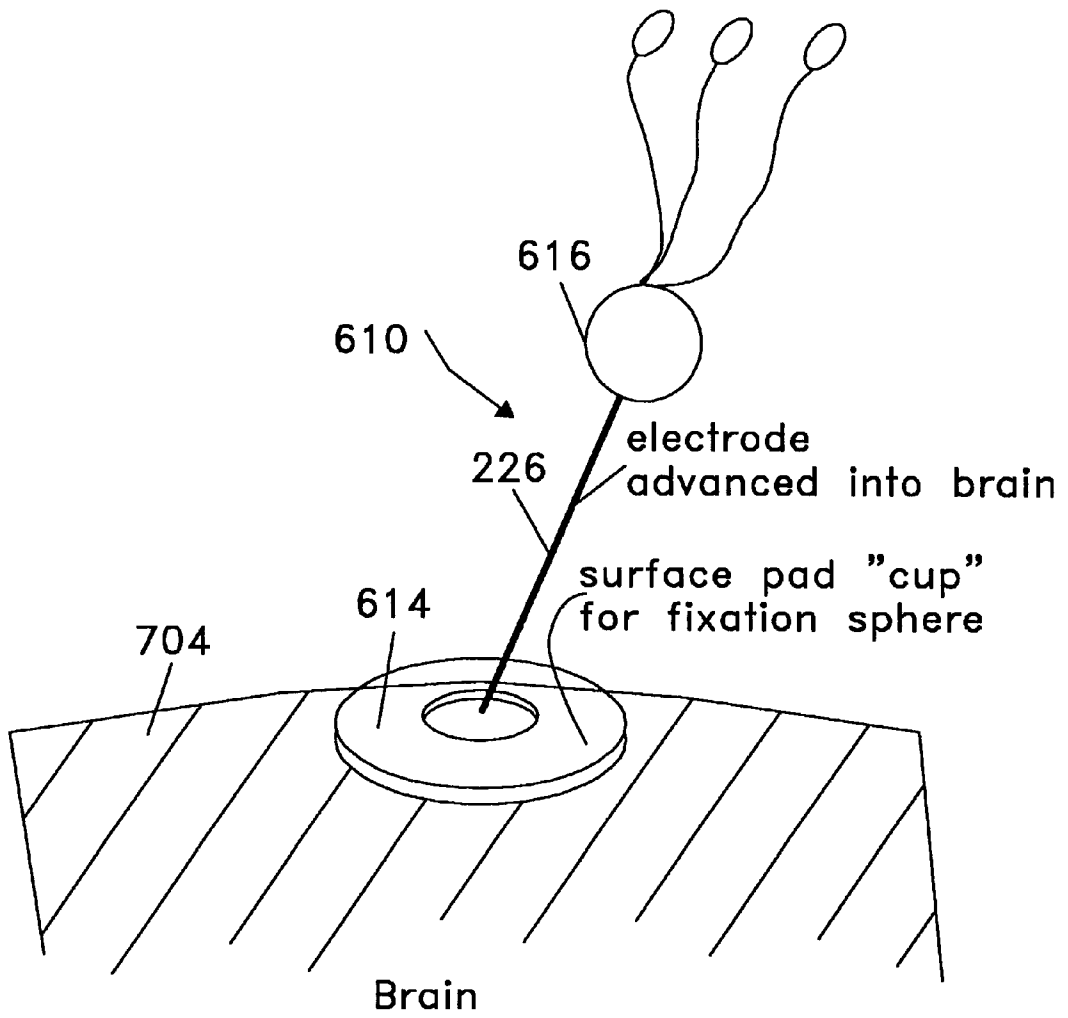

FIG. 7A

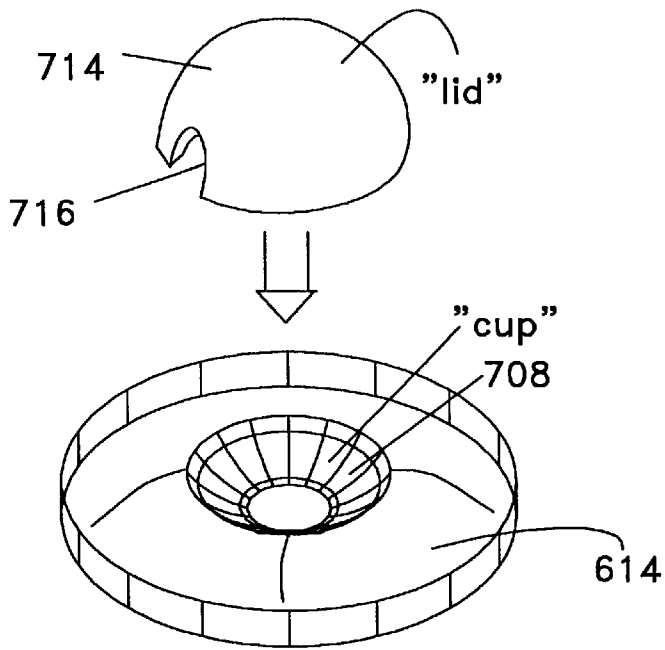

FIG. 7B

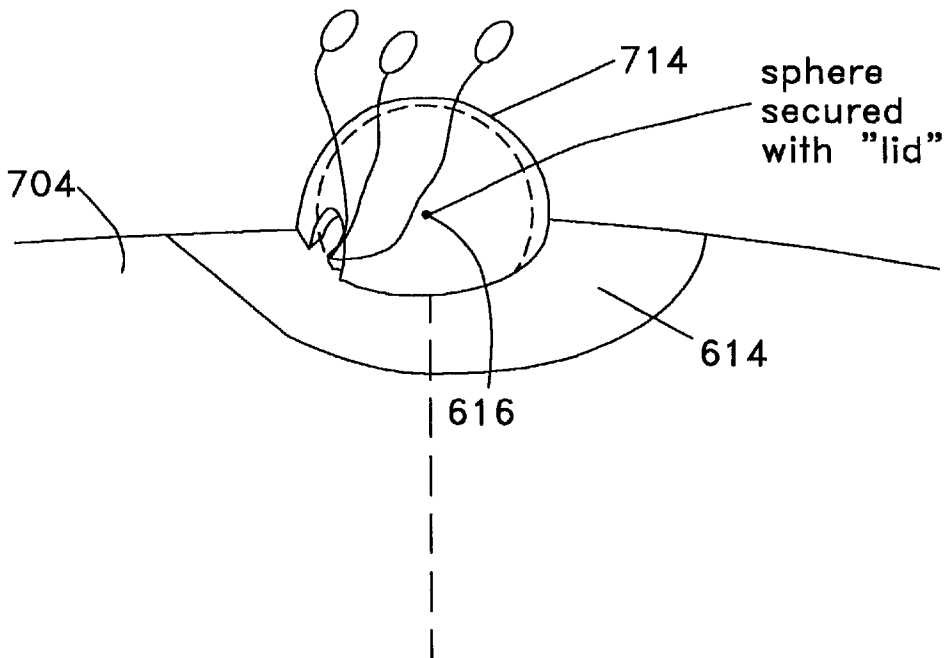

FIG. 7C

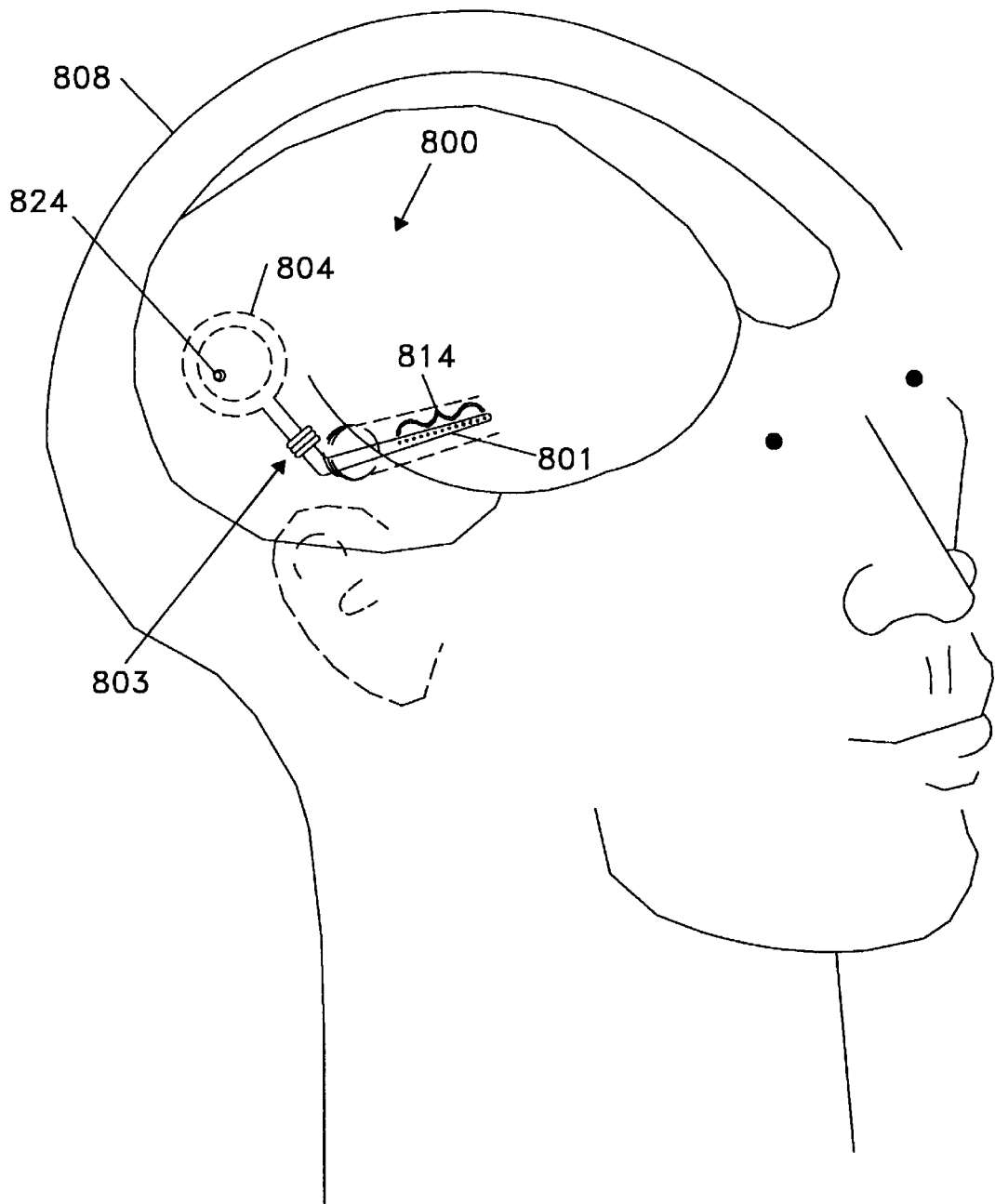

FIG. 8

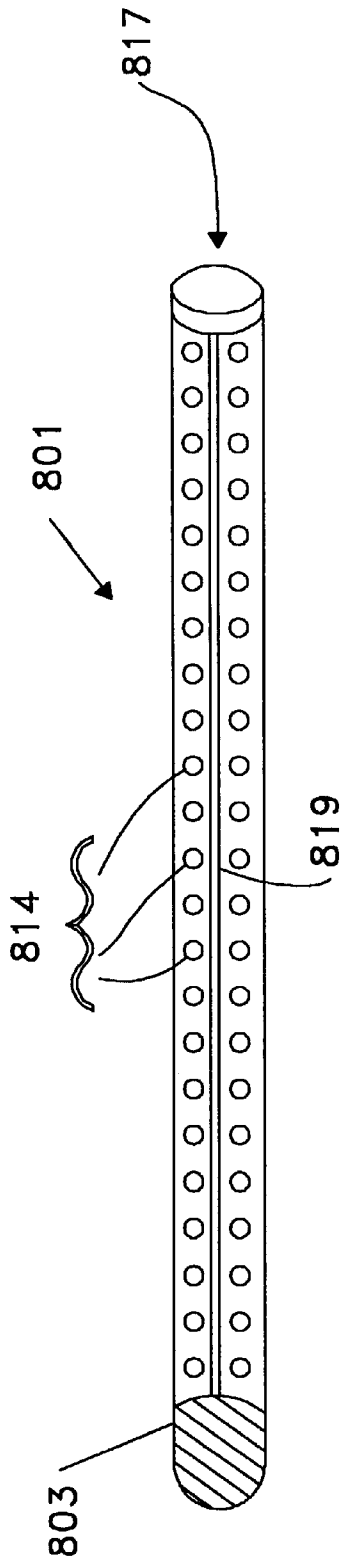

FIG. 9

HUMAN CEREBAL CORTEX NEURAL PROSTHETIC FOR TINNITUS

This application is a continuation of Application Ser. No. 08/332,755 filed Nov. 1, 1994, now U.S. Pat. No. 5,697,975, which is a continuation-in-part of U.S. application Ser. No. 08/194,017 filed Feb. 9, 1994, and which issued Mar. 5, 1996 as U.S. Pat. No. 5,496,369 each of which are incorporated herein by reference.

BACKGROUND OF THE INVENTION

1. Field of the Invention

This invention relates generally to an apparatus and method for treating tinnitus, and in particular, to a human cerebral cortex neural prosthetic for delivering geometrically dispersed electrical signals to the patient's primary auditory cortex and/or to a human cerebral cortex or the patient's thalamus neural prosthetic for microinfusing geometrically dispersed portions of drugs to the patient's primary auditory cortex or the patient's thalamus.

2. Background of the Related Art

Tinnitus is a disorder where a patient experiences a sound sensation within the head ("a ringing in the ears") in absence of an external stimulus. This uncontrollable ringing can be extremely uncomfortable and often results in severe disability. Tinnitus is a very common disorder affecting an estimated 15% of the U.S. population according to the National Institutes for Health, 1989 National Strategic Research Plan. Hence, approximately 9 million Americans have clinically significant tinnitus with 2 million of those being severely disabled by the disorder.

There are no treatments currently available that consistently eliminate tinnitus although many different types of treatments have been attempted. This wide variety of attempted treatments attests to the unsatisfactory state of current tinnitus therapy. Several more common attempts will be discussed below.

One approach involves suppression of abnormal neural activity within the auditory nervous system with various anticonvulsant or local anesthetic medications. Examples of such anticonvulsant medications include Xylocaine and Lidocaine which are administered intravenously. In addition, since the clinical impact of tinnitus is significantly influenced by the patient's psychological state, antidepressants, sedatives, biofeedback and counseling methods are also used. None of these methods has been shown to be consistently effective.

Another widely used approach to treating tinnitus involves "masking" undesirable sound perception by presenting alternative sounds to the patient using an external sound generator. In particular, an external sound generator is attached to the patient's ear (similar to a hearing aid) and the generator outputs sounds into the patient's ear. Although this approach has met with moderate success, it has several significant drawbacks. First, such an approach requires that the patient not be deaf in the ear which uses the external sound generator. That is, the external sound generator cannot effectively mask sounds to a deaf ear which subsequently developed tinnitus. Second, the external sound generator can be inconvenient to use and can actually result in loss of hearing acuity in healthy ears.

Yet another approach involves surgical resection of the auditory nerve itself. This more dangerous approach is usually only attempted if the patient suffers from large acoustic neuromas and tinnitus. In this situation, the auditory

nerve is not resected for the specific purpose of elimination of tinnitus but is removed as an almost inevitable complication of large tumor removal. In a wide series of patients with tinnitus who underwent this surgical procedure of acoustic nerve resection, only 40% were improved, 10% were improved and 50% were actually worse.

An alternative and somewhat more successful approach involves electrical stimulation of the cochlear. In patients who have tinnitus and have received a cochlear implant, as many as half reported some improvement in their tinnitus after implantation. Round window stimulation has also been useful in improving tinnitus in selected patients. However, the success rate of this approach has also remained relatively low.

Prior to the nineteenth century, physicians and scientists believed the brain was an organ with functional properties distributed equally through its mass. Localization of specific functions within subregions of the brain was first demonstrated in the 1800s, and provided the fundamental conceptual framework for all of modern neuroscience and neurosurgery. As it became clear that brain subregions served specific functions such as movement of the extremities, and touch sensation, it was also noted that direct electrical stimulation of the surface of these brain regions could cause partial reproduction of these functions.

SUMMARY OF THE INVENTION

It is therefore an object of the invention to provide a prosthetic apparatus which can be placed in one of a patient's cerebral cortex or in the patient's thalamus to reduce the effects of tinnitus.

Another object of the invention is to provide a prosthetic apparatus which can be positioned in the brain such that electric discharges can be accurately delivered to geometrically dispersed locations in either the cortex or thalamus.

Another object of the invention is to provide a prosthetic which allows a physician to physiologically test location and function of neural prosthetic electrodes to reduce or eliminate the patient's tinnitus.

Another object of the invention is to provide a prosthetic apparatus which can be positioned in the brain such that microinfusions of a drug that reduces abnormal neural activity due to tinnitus can be administered in geometrically dispersed locations in the patient's cortex or thalamus.

Another object of the invention is to provide a prosthetic apparatus which can support a reservoir of the drug so that the microinfusions can be continuously administered.

One advantage of the invention is that it reduces or eliminates the effects of tinnitus.

Another advantage of the invention is that it can utilize a single electrode.

Another advantage of the invention is that it can utilize a single catheter.

Another advantage of the invention is that it penetrates the brain as opposed to resting on the brain surface, thus requiring significantly less current to stimulate localized areas of the cortex or the thalamus.

Another advantage of the invention is that it penetrates the brain thus requiring significantly lower doses of the drug and hence reduces unwanted side effects related to inadvertent stimulation of surrounding tissue.

Another advantage of the invention is that the contacts are sufficiently closely arranged next to each other to provide high geometric resolution stimulation of the auditory cortex.

One feature of the invention is that it includes a penetrating longitudinal support or electrode.

Another feature of the invention is that it includes multiple contacts on the longitudinal support.

Another feature of the invention is that it includes a simulation device.

Another feature of the invention is that each contact can separately introduce electrical discharges in the primary auditory cortex.

Another feature of the invention is that it utilizes a catheter to administer micro-infusions of the drugs to disperse locations in the patient's cortex or thalamus.

Another feature of the invention is that the catheter includes an electrode for recording discharges in the patient's cortex or thalamus.

Another feature of the invention is that it utilizes a drug reservoir for containing reserve portions of the drug.

Another feature of the invention is that it can include a flexible wire multicontact electrode.

Another feature of the invention is that the flexible wire multicontact electrode is inserted into the brain using a rigid introducer.

Another feature of the invention is that a flat plastic plate attached to the longitudinal support (electrode) at the site of skull attachment and helps position the prosthetic in the auditory cortex. The flat plastic plate having a cup to receive a sphere coupled to leads which interconnect the contacts to the speech processor.

These and other objects, advantages and features of the present invention will become more apparent from the following description of embodiments thereof taken in conjunction with the accompanying drawings.

BRIEF DESCRIPTION OF THE DRAWINGS

FIGS. 1A and 1B show the orientation of a patient's primary auditory cortex in relation to the patients cochlea and cochlear nucleus.

FIG. 2A shows a multi-contact recording/stimulating electrode system **100** for blocking and/or masking the abnormal electrical activity present in tinnitus patients according to one embodiment of the invention. FIG. 2B shows a human cerebral cortex neural prosthetic according to one embodiment of the invention.

FIG. 3A shows a side view of a plane A which intersects a coronal section with a Sylvian fissure exposed, and FIGS. 3B and 3C show the coronal section before and after tissue is digitally "peeled off" the Sylvian fissure.

FIG. 4 shows a neural prosthetic with a support having electrical contacts and it's stimulation device.

FIG. 5 shows a prosthetic which includes two longitudinal supports according to another embodiment of the invention.

FIG. 6 shows a prosthetic according to yet another embodiment of the invention.

FIG. 7A shows the prosthetic of FIG. 6 as looking down on the patients brain surface, FIG. 7B shows a closer view of a stopping piece with a cup and a lid, and FIG. 7C corresponds to FIG. 7A with the support inserted.

FIG. 8 shows another embodiment of the invention involving drug-infusion into regionally targeted locations within the brain according to another embodiment of the invention.

FIG. 9 shows a closer view of catheter with ports or openings.

DETAILED DESCRIPTION OF PREFERRED EMBODIMENTS

It is presumed that patients perceive tinnitus because neurons within the central auditory system (Auditory Cortex

and/or Medial Geniculate Nucleus (MGN) of the Thalamus) are firing abnormally. By using sophisticated medical imaging and neurosurgical techniques discussed in U.S. patent application Ser. No. 08/194,017, the contents of which are incorporated herein by reference, specific regions in the brain can be targeted and the abnormal electrical activity blocked or masked with stimulating electrodes or with drugs delivered through precisely placed brain catheters.

The primary auditory region of the human brain is buried deep within the sylvian fissure. It is not visible from the brain surface and its exact location varies slightly from one person to the next. MRI and CT scanners were not invented at the time of Dr. Dobelle's experiments so the anatomy of the patients' auditory cortex could not be studied prior to surgery, and this region could only be visualized with difficulty in the operating room after the Sylvian fissure was surgically dissected. Once the buried auditory cortex was exposed, surface stimulating electrodes were placed by hand over the area thought to be auditory cortex and the brain was stimulated in a fashion similar to that used to generate visual phosphenes.

Reproducible sound sensations were generated in the experimental subjects. Though these preliminary findings were encouraging, a range of limitations precluded further work by this group. Among the more daunting problems the Utah group faced were recruiting suitable patients for the experimental study and obtaining good stimulation characteristics from the experimental surface electrodes. The minimal stimulation threshold for eliciting sound sensations was found to be 6 milliamperes, which is too high to be tolerated chronically and is thousands of times greater than currents found subsequently to be required to generate phosphenes in visual cortex using penetrating electrodes.

Recent advances in MRI and computer technology now allow detailed preoperative imaging of human auditory cortex.

An important aspect of the cochlear implant technology, which is now highly refined, involves transducing sound into complex electrical stimulation sequences. This large body of technical knowledge developed over the last twenty years will be directly applicable to the treatment of tinnitus via the auditory cortex prosthetic device.

Normal Hearing

Mechanisms of human hearing are reviewed briefly to provide a framework for discussion of the tinnitus masking system. The auditory system is composed of many structural components that are connected extensively by bundles of nerve fibers. The system's overall function is to enable humans to extract usable information from sounds in the environment. By transducing acoustic signals into electrical signals that can then be processed in the brain, humans are able to discriminate amongst a wide range of sounds with great precision.

FIGS. 1A and 1B show a side and front view of areas involved in the hearing process. In particular, the normal transduction of sound waves into electrical signals occurs in cochlea **110**, a part of the inner ear located within temporal bone (not shown). Cochlea **110** is tonotopically organized, meaning different parts of cochlea **110** respond optimally to different tones; one end of cochlea **110** responds best to high frequency tones, while the other end responds best to low frequency tones. Cochlea **110** converts the tones to electrical signals which are then received by cochlea nucleus **116**. This converted information is passed from cochlea **110** into brain stem **114** by way of electrical signals carried along the acoustic nerve and in particular, cranial nerve VIII (not shown).

The next important auditory structure encountered is cochlea nucleus **116** in the brain stem **114**. As the acoustic nerve leaves the temporal bone and enters skull cavity **122**, it penetrates brain stem **114** and relays coded signals to cochlear nucleus **116**, which is also tonotopically organized. Through many fiber-tract interconnections and relays (not shown), sound signals are analyzed at sites throughout brain stem **114** and thalamus **126**. The final signal analysis site is auditory cortex **150** situated in temporal lobe **156**.

The mechanisms of function of these various structures has also been extensively studied. The function of cochlea **110** is the most well-understood and the function of auditory cortex **150** is the least understood. For example, removal of the cochlea **110** results in complete deafness in ear **160**, whereas removal of auditory cortex **150** from one side produces minimal deficits. Despite extensive neural connections with other components of the auditory system, auditory cortex **150** does not appear to be necessary for many auditory functions.

Advanced imaging combined with an intraoperative stereotactic system now enable placement of penetrating electrodes into auditory cortex during routine epilepsy surgery without dissection of the Sylvian fissure.

Primary auditory cortex **150** in FIGS. 1A and 1B is tonotopically organized, meaning stimulation in different areas is likely to cause the patient to perceive different tones. These tones form the building blocks of complex sound phenomena such as speech. Tonotopic organization is a fundamental characteristic of the cochlea and cochlear nucleus as well, as discussed above. Auditory cortex **150**, however, has its tonotopic map stretched across a larger volume of tissue (greater than twice the volume of cochlear nucleus **116**). Greater tissue volume enables placement of a greater number of electrical contacts for a given tonotopic zone. This results in increased signal resolution and improved clarity of auditory sensation. Finally, because of anatomical differences, auditory cortex **150** can accommodate penetrating electrode arrays.

Stimulating Electrode

FIG. 2A shows a multi-contact recording/stimulating electrode system **100** for blocking and/or masking the abnormal electrical activity present in tinnitus patients according to one embodiment of the invention. In particular, system **100** includes a multi-contact stimulating/recording electrode **104** connected to cables **108** via connector **112**. Cables **108** enter skull **116** at burr hole opening **120** of skull **116** and are connected to a stimulation device **410** positioned in subcutaneous tissue of axial skeleton (thorax or abdomen).

FIG. 2B shows a closer view of multi-contact stimulating/recording electrode **104** of electrode system **100**. Electrode **104** has a first end **206a** and a second end **206b** which is blunt or smoothly curved. Electrode **104** has electrical contacts **220** along a longitudinal support **226**. Support **226** can be anywhere from several millimeters long to several centimeters long. Electrical contacts **220** are small metal pads which can be separately electrically charged via respective wires **232** available at first end **206a**. Wires **232** are coupled to stimulation device **410** (see FIGS. 2A and 4). Electrical contacts **220** are spaced approximately **10** micrometers to several millimeters apart and preferably approximately 50 to 150 micrometers apart. Application of a voltage to contacts **220** near first end **206a** results in stimulating low (or high--to be determined by questioning the patient) tones in auditory cortex **150** (see FIGS. 1A and 1B), whereas application of a voltage to contacts **220** near

second end **206b** results in stimulation of high (or low) tones in auditory cortex **150**.

Electrode **104** is stereotaxically placed into the primary auditory cortex of the patient with tinnitus. This can be done using a standard stereotaxic head frame under local anesthesia. That is, the above discussed three dimensional computerized MRI reconstruction method of FIGS. 3A-3C is used to stereotaxically place electrode **104** within the targeted region of auditory cortex **150**. Correct placement is confirmed by presenting a series of tones to the patient and mapping the tonotopic responses of the neurons along electrode **104**.

In deaf patients, this mapping procedure is not possible, but mapping can still be carried out using microstimulation currents delivered to various contacts along electrode **104**. The deaf patient describes the relative pitch of the sounds he or she perceives following stimulation, whereby the electrically stimulated location and parameters which most closely match the patient's tinnitus are determined. This approach could be used in the thalamus (MGN) as well, but the preferred embodiment involves implantation in the cortex. Regardless of whether or not stimulating electrode **104** is placed into the correct region of the cortex or into the correct region of the MGN, electrode **104** is coupled to stimulation device **410** via cables **108** and in particular, wires **232a**.

Longitudinal support **226** can be a rigid support or a flexible wire with a rigid introducer which enables the physician to introduce electrode **104** into a patient's brain and then subsequently remove the rigid introducer thereby exposing electrical contacts **220** to auditory cortex **150**. Support **226** can be one of the probes shown in FIGS. 3-5 in "Possible Multichannel Recording and Stimulating Electrode Arrays: A Catalog of Available Designs" by the Center for Integrated Sensors and Circuits, University of Michigan Ann Arbor, Michigan, the contents of which are incorporated herein by reference. Alternative electrodes such as Depthalon Depth Electrodes and interconnection cables from PMT Corporation **1500** Park Road, Chanhassen, Minn., **55317** could also be used as support **226** and electrical couplers between contacts **220** and a speech processor (**410** in FIG. 4).

Electrical contacts **220** can operate as high impedance (megohms) contacts or low impedance (a few ohms to several thousand ohms) contacts as some of the electrodes. This enables the contacts to output a small (a few microamperes as opposed to a few milliamperes) current. High impedance contacts localize the potentials applied to the patient's primary auditory cortex to approximately a few hundred micrometers. The localization of applied electric charges corresponds to the tonotopic spacing of nerve cell pairs.

Electrode **104** is arranged along a longitudinal direction of auditory cortex **150**. However, auditory cortex **150** is located in the transverse temporal gyrus and is buried deep within the Sylvian fissure. Consequently, its location cannot be determined simply by looking at an exposed surface of the brain. Therefore, MRI imaging techniques must be employed to reveal the exact orientation of auditory cortex **150**.

A single coronal image of an individual's brain cannot reveal the exact orientation of auditory cortex **150**. However, for treatment of tinnitus, a standard coronal MRI provides a fairly good estimate as to the location of the target region, whether or not the target region is the auditory cortex or the thalamus. However, if more precise targeting is desired, a series of two dimensional images must be obtained and a

resulting 3-D MRI image constructed. Once such an image is constructed, the digital data making up that image can be transformed to provide a view of the Sylvian fissure. This in turn exposes auditory cortex 150 as a mole-like mound. That is, tissue on top of the digital image can be “peeled off” to expose the sylvian fissure and consequently auditory cortex 150 “pops out” of the image. This process is described in “Three-dimensional In Vivo Mapping of Brain Lesions in Humans”, by Hanna Damasio, MD, Randall Frank, the contents of which are incorporated herein by reference.

FIG. 3A shows a side view of a plane A which intersects a coronal section 310 as well as a view of coronal section 310 with Sylvian fissure 316 exposed. FIGS. 3B and 3C show coronal section 310 before and after tissue is digitally “peeled off” to expose auditory cortex 150. One or more resulting mounds 320 is revealed in FIG. 3C and this mound corresponds to auditory cortex 150 of FIG. 1B. Mound 320 does not appear until after tissue on the underside of Sylvian fissure 316 is reconstructed to provide the 3-D image. Once the exact location and orientation of mound 320 and consequently auditory cortex 150 have been determined using these 3-D MRI image processing techniques, electrode 104 can be accurately inserted into auditory cortex 150.

FIG. 4 shows electrode 104 just prior to insertion into auditory cortex 150. In addition, FIG. 4 shows stimulation device 410 coupled to wires 232 via cable 108. Stimulation device 410 is a chronic electrical stimulation device. This stimulator device is well tested and widely available. Examples include chronic epidural simulators made by Medtronic used for chronic back and leg pain and deep brain stimulators, as well as nearly all types of cochlear implants.

The above electrical implantation technique for tinnitus is quick and safe, e.g., over 100 auditory cortex region electrode implantations have been performed in patients being evaluated for medically intractable seizures as reported by a French epilepsy surgery group. In addition, since electrode 104 is placed in the exact site of presumed abnormal neuronal electrical activity, it is much more effective in disrupting or altering abnormal neuronal electrical activity, thereby eliminating tinnitus. Moreover, preliminary testing has shown that placement of electrode 104 within the central auditory system causes patients to perceive sounds, and this will likely be the case even in patients who are deaf from causes refractory to cochlear implantation. Also, stimulation in the auditory cortex does not impair hearing in tinnitus patients who do have good hearing.

FIG. 5 shows an electrode 510 which includes two longitudinal supports 226a and 226b according to another embodiment of the invention. Although two supports are shown, three or more such supports could be used. Longitudinal support 226a is connected to cable 108a containing wires 232a via connector 112a and longitudinal support 226b is connected to cable 108b containing wires 232b via connector 112b. Cables 108a and 108b are again connected to stimulation device 410 as in FIG. 4.

FIG. 6 shows a electrode 610 according to yet another embodiment of the invention. In particular, FIG. 6 shows longitudinal support rod 226 with first end 606a and second end 606b. End 606a is arranged in the region of auditory cortex 150 with low tones (or high tones as previously discussed) and second end 606b is arranged in the region of auditory cortex 150 with high (or low) tones in a manner similar to first end 206a and second end 206b of FIG. 2B. Here, however, longitudinal support 226 has a sphere 616 which is stopped by a stopping piece 614. This enable the

physician to insert longitudinal support 226 at a wide range of angles and yet secure electrode 610 once longitudinal support 226 has been inserted.

FIG. 7A shows electrode 610 of FIG. 6 as looking down on the patients brain surface 704. FIG. 7B shows a closer view of stopping piece 614 with a cup 708 and a lid 714 with a notch 716 for passing leads 232. FIG. 7C corresponds to FIG. 7A with support 226 inserted into surface 704 and sphere 616 resting in cup 708. (FIG. 7B) FIG. 7C also shows lid 714 covering sphere 616 with leads 232 extending out of notch 716.

FIG. 8 shows another embodiment of the invention involving drug-infusion into regionally targeted locations within the brain. The alternative drug-infusion treatment strategy relies on the same principal of regionally targeted treatment within the brain, but employs a different effector to eliminate the abnormal neural activity causing tinnitus. Namely, a small drug infusion catheter 801 is stereotaxically placed into either the auditory cortex or thalamus (MGN) and microinfusions of various drugs that block abnormal neural activity are infused into the targeted locations.

Referring in more detail to FIG. 8, a drug infusion catheter-recording device 800 is connected to an injectable (rechargeable) drug reservoir-pump 804 via connector 803 which is secured with sutures widely used in neurosurgery. Pump 804 is secured to the patient’s skull 808 under the scalp and is not exposed to the external environment. Pump 804 has a valve 824 which can be accessed externally so that additional drugs can be injected via a syringe (not shown) without reopening the patient’s scalp. Catheter 801 has multiple ports 814 from which the drugs are microinfused into the targeted brain regions.

FIG. 9 shows a closer view of catheter 801 with ports or openings 814. Catheter can be made, for example, of silastic such as the catheters sold by Radionics, Codman, and Medtronic. Catheter 801 need not have a circular cross-section 817 and instead can be flat, elliptical or any other shape which facilitates broader diffusion of the drug. Catheter 801 can include a small embedded recording-stimulating electrode 819 which can be connected to stimulation device 410 so that it can be properly positioned. Electrophysiologic recording data from this special catheter electrode will provide physiologic confirmation of proper catheter position in auditory cortex. The diameters of ports (or openings) 814 can be approximately between 10 micrometers and several millimeters and preferably between approximately 40 micrometers and 1 millimeter. The centers of ports 814 can also be tens of micrometers apart to millimeters apart and the spacing need not be uniform.

Pumps manufactured by Medtronic and Alzet can serve as injectable drug reservoir-pump 804. Examples of drugs that could be infused include anticonvulsants such as Dilantin and inhibitory neurotransmitters such as GABA and local anesthetics such as lidocaine. In high enough concentrations, these compounds should block abnormal neuronal discharges. By delivering the drugs to the specific central nervous system target, significantly higher concentrations of the drug reach their target without exposing non-targeted surrounding tissue, as compared to the concentrations which could be delivered by simply systematically administering the same drug orally or intravenously. Consequently, this strategy should result in marked improvement in efficacy while avoiding toxic side effects.

The precise amount of drug infusion depends on the type of drug but can be determined at the outset of implantation. In particular, catheter 801 is initially inserted into the

targeted location in the manner described above. The patient is then asked if there is any noticeable reduction in ringing due to the tinnitus as the amount of drug infusion is manually adjusted. The amount of infusion is that amount which is required to eliminate the ringing. Once the amount is determined, the appropriate chronic infusion pump **804** is connected to catheter **801** and all incisions are closed. Post-operative modifications of infusion rates can be carried out using percutaneous radio control techniques, e.g., Medtronic.

As mentioned above, the alternative drug-infusion treatment strategy relies on the same electrode placement principals as described above with respect to FIGS. **3A-3C**. Namely, a series of images must again be obtained and a resulting 3-D MRI image constructed. Once the image is constructed, the digital data making up that image can be transformed to provide a view of the Sylvian fissure. This in turn exposes auditory cortex **150** as a mole-like mound. Again, tissue on top of the digital image can be "peeled off" to expose the sylvian fissure and consequently auditory cortex **150** "pops out" of the image.

Numerous additional modifications and variations of the present invention are possible in light of the above teachings. It is therefore understood that the invention may be practiced otherwise than as specifically claimed.

What is claimed is:

1. A neural prosthetic apparatus for a patient with tinnitus, comprising:

a stimulation device for outputting at least one electrical signal; and

at least one electrode configured to be placed in the brain of a patient, said at least one electrode having a plurality of electrical contacts electrically coupled to said stimulation device, wherein the stimulation devices the at least one electrode, and the plurality of electrical contacts are configured to output at least one electrical discharge in accordance with said electrical signal, and to provide localized potentials that correspond to spacing of nerve cell pairs in the brain of the patient.

2. The neural prosthetic apparatus according to claim **1**, wherein said at least one electrode is configured to be placed in at least one of (a) the auditory cortex (b) the thalamus, and (c) the auditory cortex and thalamus of the brain of said patient.

3. The neural prosthetic apparatus according to claim **1**, further comprising electrical coupling means for electrically coupling said plurality of electrical contacts with said stimulation device.

4. The neural prosthetic apparatus according to claim **1**, further comprising a holding means for holding said at least one electrode device.

5. The neural prosthetic apparatus according to claim **1**, wherein said at least one electrode is substantially cylindrical.

6. The neural prosthetic apparatus according to claim **1**, wherein said electrical contacts are spaced from about 10 micrometers to about 2 millimeters apart.

7. The neural prosthetic apparatus according to claim **1**, wherein said electrical contacts are spaced from about 10 micrometers to about 150 micrometers apart.

8. The neural prosthetic apparatus according to claim **1**, wherein said electrical contacts are spaced from about 50 micrometers to about 150 micrometers apart.

9. The neural prosthetic apparatus according to claim **1**, wherein said stimulation device is capable of adjustably outputting electrical signals with sufficient electrical power to eliminate the symptoms of the tinnitus.

10. The neural prosthetic device according to claim **1**, wherein said at least one electrode is adapted to be tonotopically arranged along said patient's auditory cortex.

11. The neural prosthetic device according to claim **1**, wherein said at least one electrode is adapted to be tonotopically arranged along said patient's thalamus.

12. The neural prosthetic device according to claim **1**, wherein said plurality of electrical contacts are capable of independently outputting at least one electrical discharge in accordance with said at least one electrical signal.

13. A neural prosthetic for a patient in need thereof, comprising:

circuit means for outputting at least one stimulation signal; and

stimulation means for outputting at least one electrical discharge in response to the stimulation signal, wherein the stimulation means is configured to be inserted into a brain of a patient, and to provide localized potentials that correspond to spacing of nerve cell pairs in the brain of the patient.

14. The neural prosthetic of claim **13**, wherein the stimulation means is configured to be inserted into at least one of (a) the auditory cortex, (b) the thalamus, and (c) the auditory cortex and thalamus of said patient.

15. The neural prosthetic of claim **13**, wherein the stimulation means comprises a plurality of means for outputting electrical discharges.

16. The neural prosthetic of claim **13**, wherein the circuit means is configured to output a plurality of stimulation signals, and wherein the stimulation means is configured to output electrical discharges corresponding to the plurality of stimulation signals at a corresponding plurality of locations.

17. The neural prosthetic of claim **13**, wherein the stimulation means is configured to be tonotopically arranged along at least one of (a) the auditory cortex, (b) the thalamus, and (c) the auditory cortex and thalamus of the brain of said patient.

18. The neural prosthetic of claim **17**, wherein the stimulation means is configured to selectively output electrical discharges to different locations within the brain of said patient.

19. A neural prosthetic for a patient in need thereof, comprising:

at least one circuit for outputting at least one electrical signal; and

at least one electrode connected to the at least one circuit for outputting at least one electrical discharge in response to the at least one electrical signal, wherein the electrode is configured to be inserted into a brain of a patient, and to provide localized potentials that correspond to spacing of nerve cell pairs in the brain of the patient.

20. The neural prosthetic of claim **19**, wherein the circuit is configured to be adjustable such that the neural prosthetic can achieve a desired effect on said patient.

21. A neural prosthetic apparatus as claimed in claim **1**, wherein said plurality of electrical contacts comprise a plurality of high impedance electrical contacts.