



US007077822B1

(12) **United States Patent**
Howard, III

(10) **Patent No.:** **US 7,077,822 B1**
(45) **Date of Patent:** **Jul. 18, 2006**

(54) **STEREOTACTIC HYPOTHALAMIC OBESITY PROBE**

(75) Inventor: **Matthew A. Howard, III**, Iowa City, IA (US)

(73) Assignee: **The University of Iowa Research Foundation**, Iowa City, IA (US)

(*) Notice: Subject to any disclaimer, the term of this patent is extended or adjusted under 35 U.S.C. 154(b) by 0 days.

(21) Appl. No.: **09/661,153**

(22) Filed: **Sep. 13, 2000**

Related U.S. Application Data

(60) Division of application No. 08/884,654, filed on Jun. 27, 1997, now Pat. No. 6,129,685, which is a continuation-in-part of application No. 08/549,165, filed on Oct. 27, 1995, now Pat. No. 5,843,093, which is a continuation-in-part of application No. 08/332,755, filed on Nov. 1, 1994, now Pat. No. 5,697,975, which is a continuation-in-part of application No. 08/194,017, filed on Feb. 9, 1994, now Pat. No. 5,496,369.

(51) **Int. Cl.**
A61M 37/00 (2006.01)
A61M 31/00 (2006.01)

(52) **U.S. Cl.** **604/93.01**; 604/67; 604/158; 604/258; 604/264; 604/523; 604/529; 604/288.02; 600/378; 600/544

(58) **Field of Classification Search** 604/264, 604/117, 523, 533, 131, 151-153, 65-67, 604/93.01, 94.01, 890.1, 891.1, 258; 600/373, 600/378, 372, 377, 381, 393, 433-435, 386, 600/544, 545, 417; 606/108, 130
See application file for complete search history.

(56) **References Cited**

U.S. PATENT DOCUMENTS

3,147,750 A 9/1964 Fry 128/2.1

3,640,269 A * 2/1972 Delgado 600/573
3,674,014 A * 7/1972 Tillander 138/120
3,762,396 A 10/1973 Ballentine et al. 128/1 C
3,941,119 A * 3/1976 Corrales 600/434
4,154,247 A 5/1979 O'Neill 607/125
4,172,451 A 10/1979 Kline 600/374

(Continued)

FOREIGN PATENT DOCUMENTS

EP 0 124 930 11/1984

(Continued)

OTHER PUBLICATIONS

James P. Morgan, "The First Reported Case of Electrical Stimulation of the Human Brain," J. Hist. Med., Jan., 1982, pp. 51-63.

(Continued)

Primary Examiner—Nicholas D. Lucchesi
Assistant Examiner—Catherine S. Williams
(74) *Attorney, Agent, or Firm*—Fleshner & Kim, LLP

(57) **ABSTRACT**

Apparatus and methods for regulating the appetite of an individual suffering from morbid obesity, the apparatus including a plurality of stimulation electrodes arranged longitudinally on at least one electrode support shaft for insertion within the hypothalamus for outputting electrical discharges to specific sites within the hypothalamus. Each of the plurality of stimulation electrodes may be independently controlled. Electrical discharge of various frequencies transmitted from one or more of the plurality of stimulation electrodes, and delivered to a region of the hypothalamus that is involved with either stimulating or inhibiting appetite, may be used to regulate appetite in the individual. Alternatively, an individual's appetite may be regulated by the microinfusion from at least one microinfusion catheter of an appropriate quantity of a suitable drug to a distinct site or region within the hypothalamus.

43 Claims, 46 Drawing Sheets

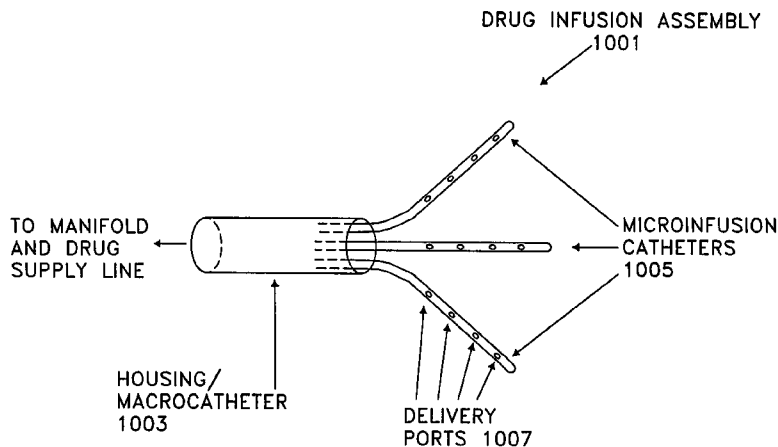

U.S. PATENT DOCUMENTS

4,244,362 A 1/1981 Anderson 600/585
 4,245,645 A 1/1981 Arseneault et al.
 4,248,224 A * 2/1981 Jones 604/508
 4,357,497 A 11/1982 Hochmair et al. 179/107 E
 4,360,019 A 11/1982 Portner et al. 128/213 R
 4,445,501 A * 5/1984 Bresler 600/12
 4,461,304 A 7/1984 Kuperstein 128/642
 4,490,137 A 12/1984 Moukheibir 604/28
 4,522,212 A 6/1985 Gelinas et al.
 4,542,123 A 9/1985 Wurtman 514/3
 4,565,200 A 1/1986 Cosman 600/585
 4,646,744 A 3/1987 Capel 128/423 R
 4,692,146 A * 9/1987 Hilger 604/288.01
 4,710,177 A * 12/1987 Smith et al. 604/185
 4,735,968 A 4/1988 Guth 514/561
 4,762,135 A 8/1988 Van Der Puije et al. 128/784
 4,850,359 A 7/1989 Putz 128/642
 4,871,351 A * 10/1989 Feingold 128/DIG. 12
 4,892,102 A 1/1990 Astrinsky 128/642
 4,907,589 A 3/1990 Cosman 606/34
 4,940,588 A * 7/1990 Sparks et al. 424/440
 4,968,306 A 11/1990 Huss et al.
 4,969,468 A 11/1990 Byers et al. 128/642
 5,000,194 A 3/1991 van den Honert et al. .. 128/784
 5,041,107 A * 8/1991 Heil, Jr. 604/891.1
 5,053,002 A 10/1991 Barlow
 5,066,278 A * 11/1991 Hirschberg et al. 604/256
 5,084,007 A 1/1992 Malin et al. 604/20
 5,099,846 A 3/1992 Hardy 128/653.1
 5,100,395 A * 3/1992 Rosenberg 604/284
 5,119,832 A 6/1992 Xavier 128/786
 5,120,713 A 6/1992 Mugica 514/17
 5,169,380 A 12/1992 Brennan 600/26
 5,169,637 A 12/1992 Lenk et al. 424/450
 5,176,652 A 1/1993 Littrell 604/167
 5,188,104 A 2/1993 Wernicke et al. 128/419 R
 5,221,283 A 6/1993 Chang 606/130
 5,250,033 A 10/1993 Evans et al. 604/160
 5,254,084 A * 10/1993 Geary 604/29
 5,254,105 A 10/1993 Haaga 604/265
 5,262,178 A 11/1993 Camine et al. 424/94.67
 5,263,480 A 11/1993 Wernicke et al. 607/118
 5,271,397 A 12/1993 Seligman et al. 607/10
 5,298,622 A 3/1994 Portoghese et al. 546/15
 5,308,320 A * 5/1994 Safar et al. 604/6.14
 5,327,889 A 7/1994 Imran 600/585
 5,328,460 A 7/1994 Lord et al. 604/67
 5,332,401 A 7/1994 Davey et al. 607/116
 5,340,802 A 8/1994 Shiosaki et al. 514/18
 5,341,807 A 8/1994 Nardella 128/642
 5,353,807 A * 10/1994 DeMarco 600/585
 5,365,939 A 11/1994 Ochs 128/732
 5,373,095 A 12/1994 Johnson et al. 540/95
 5,380,288 A 1/1995 Hart et al. 604/167
 5,385,146 A 1/1995 Goldreyer 128/642
 5,385,560 A 1/1995 Wulf 604/264
 5,389,101 A 2/1995 Heilbrun et al. 606/130
 5,397,788 A 3/1995 Horwell et al. 514/307
 5,399,565 A 3/1995 Greenwood et al. 514/314
 5,405,375 A 4/1995 Ayers et al. 607/122
 5,417,207 A 5/1995 Young et al. 600/323
 5,425,382 A * 6/1995 Golden et al. 128/899
 5,429,131 A * 7/1995 Scheinman et al. 600/374
 5,429,161 A 7/1995 Allard 600/374
 5,429,582 A 7/1995 Williams 600/2
 5,443,710 A 8/1995 Broderick 204/403
 5,458,582 A * 10/1995 Nakao 604/264
 5,458,631 A 10/1995 Xavier 607/117
 5,462,544 A 10/1995 Saksena et al. 606/15

5,484,399 A * 1/1996 DiResta et al. 604/21
 5,487,739 A 1/1996 Aebischer et al. 604/890.1
 5,496,369 A 3/1996 Howard, III 623/10
 5,523,306 A 6/1996 Horwell et al. 514/310
 5,531,679 A * 7/1996 Schulman et al. 604/65
 5,531,759 A 7/1996 Kensey et al. 606/213
 5,536,267 A 7/1996 Edwards et al. 606/41
 5,540,734 A 7/1996 Zabara 607/46
 5,545,193 A 8/1996 Fleischman 607/99
 5,545,200 A 8/1996 West et al. 607/122
 5,545,201 A 8/1996 Helland 607/127
 5,545,219 A 8/1996 Kuzma 623/10
 5,551,426 A 9/1996 Hummel et al. 600/374
 5,554,643 A 9/1996 Horwell et al. 514/419
 5,582,609 A 12/1996 Swanson et al. 606/39
 5,584,847 A 12/1996 Duluco et al. 606/185
 5,642,544 A 7/1997 Munoz 606/15
 5,676,673 A * 10/1997 Ferre et al. 606/130
 5,697,975 A 12/1997 Howard, III et al. 623/10
 5,702,429 A 12/1997 King 607/116
 5,720,720 A * 2/1998 Laske et al. 604/21
 5,772,629 A * 6/1998 Kaplan 604/508
 5,855,576 A 1/1999 LeVeen et al. 606/41
 5,983,126 A 11/1999 Wittkamp 600/509

FOREIGN PATENT DOCUMENTS

EP 0158397 10/1985
 EP 0259906 3/1988

OTHER PUBLICATIONS

A. Earl Walker, "The Development of the Concept of Cerebral Localization in the Nineteenth Century," *Bulletin His. Med.*, vol. 31, No. 2, Mar. -Apr., 1957, pp. 99-121.
 Penfield et al., "Somatic Motor and Sensory Representation in the Cerebral Cortex of Man as Studied by Electrical Stimulation," *Brain*, vol. 60, 1937, pp. 389-443.
 Penfield et al., "The Brain's Record of Auditory and Visual Experience," *Brain*, vol. 86, Dec. 1963, pp. 596-696.
 Dobbelle et al., "Artificial Vision for the Blind: Electrical Stimulation of Visual Cortex Offers Hope for a Functional Prosthesis," *Science*, vol. 183, 1974, pp. 440-444.
 Dobbelle et al., "A Prosthesis for the Deaf Based on Cortical Stimulation," *Ann. Otol.*, vol. 82, 1973, pp. 445-463.
 Cohen et al., "A Prospective, Randomized Study of Cochlear Implants," *N.E. J. of Med.*, vol. 328, No. 4, Jan. 1993, pp. 233-237.
 Eisenberg et al., "Electrical Stimulation of the Auditory Brain Stem Structure in Deafened Adults," *J. Rehab. Research*, vol. 24, No. 3, 1987, pp. 9-22.
 Center for Integrated Sensors and Circuits, "Passive Multichannel Recording and Stimulating Electrode Arrays: A Catalog of Available Designs", Jul. 1991.
 Medtronic, The ITREL® II, The third generation of excellence, (1991).
 Eggermunt, "Neural Interaction in Cat Primary Auditory Cortex," *Oct. 1992*; pp 1216-1228 *J. of Neurophysiology*, vol. 68, No. 4.
 Bak, M. et al., Visual Sensations produced by Intracortical Microstimulation of the Human Occipital Cortex, *Med. Biol. Eng. Comput.*, 28:257-259 (1990).
 Brindley, G.S. et al., The Sensations Produced by Electrical Stimulation of the Visual Cortex, *J. Physiol.* 196:479-493 (1968).
 Damasio et al., Three-dimensional In Vivo Mapping of Brain Lesions in Humans, *Arch. Neurol* 49:137-143 (Feb. 1992).

Drake, K.L., et al. : Performance of Planar Multisite Microprobes in Recording Extracellular Single-Unit Intracortical Activity, IEEE Trans. BME 35-719-732 (1988).
Hitselberger, W.e. et al., : Cochlear Nucleus Implant, Otolaryngol head neck-Surg. 92:52-54 (1984).
Martuza, R.L. et al., Neurofibromatosis 2 (Bilateral Acoustic Neurofibromatosis), N. Engl. J. Med. 318: 684-688 (1988).
Penfield, W. et al., Epilepsy and Functional Anatomy of the Human Brain, Little, Brown and Company, Boston, (1954).

Ifukube, T. et al, "Design of an Implantable Tinnitus Suppressor By Electrical Cochlear Stimulation", Biomechanics, Rehabilitation, Electrical Phenomena, Biomaterials, Oct. 28-31, 1993, pp 1349-1350.
Dobelle, W.H., "A Prosthesis for the Deaf Based on Cortical Stimulation", Annals of Otology, Rhinology and Laryngologyad., vol. 82, 1973, pp 445-463.

* cited by examiner

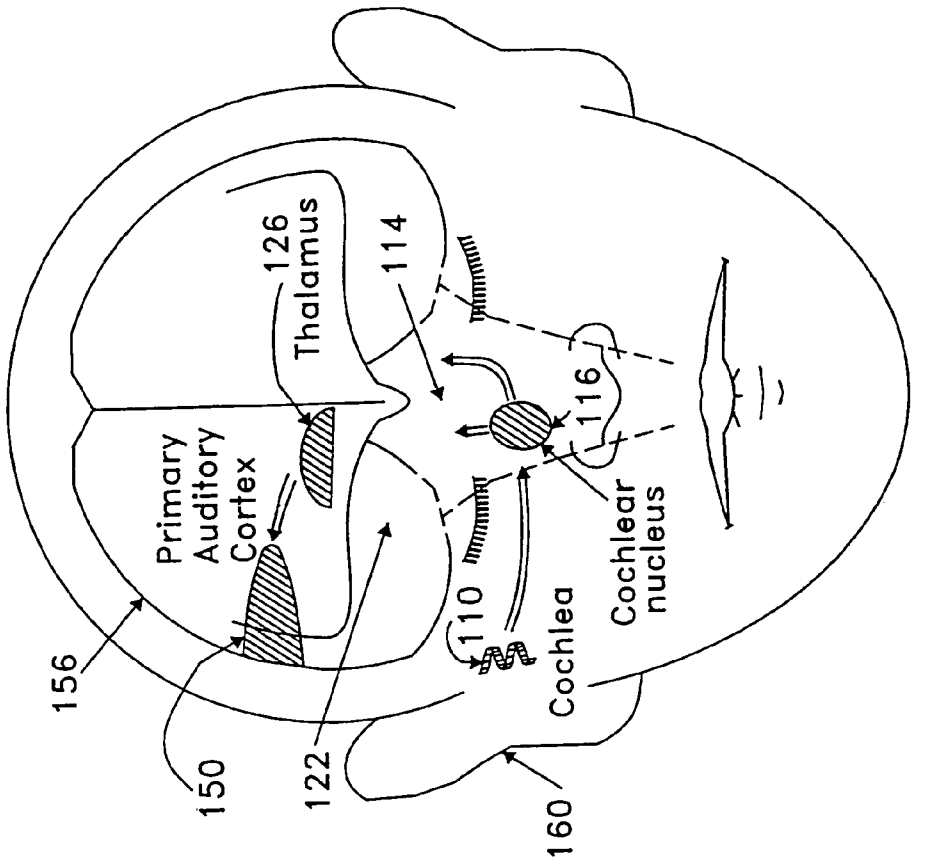

FIG. 1A

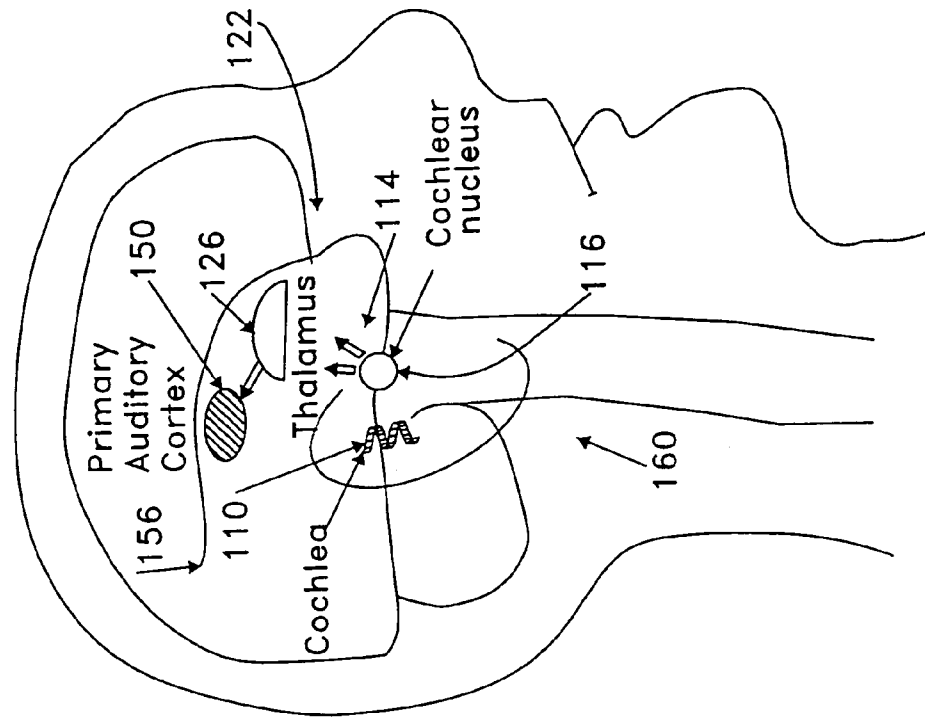

FIG. 1B

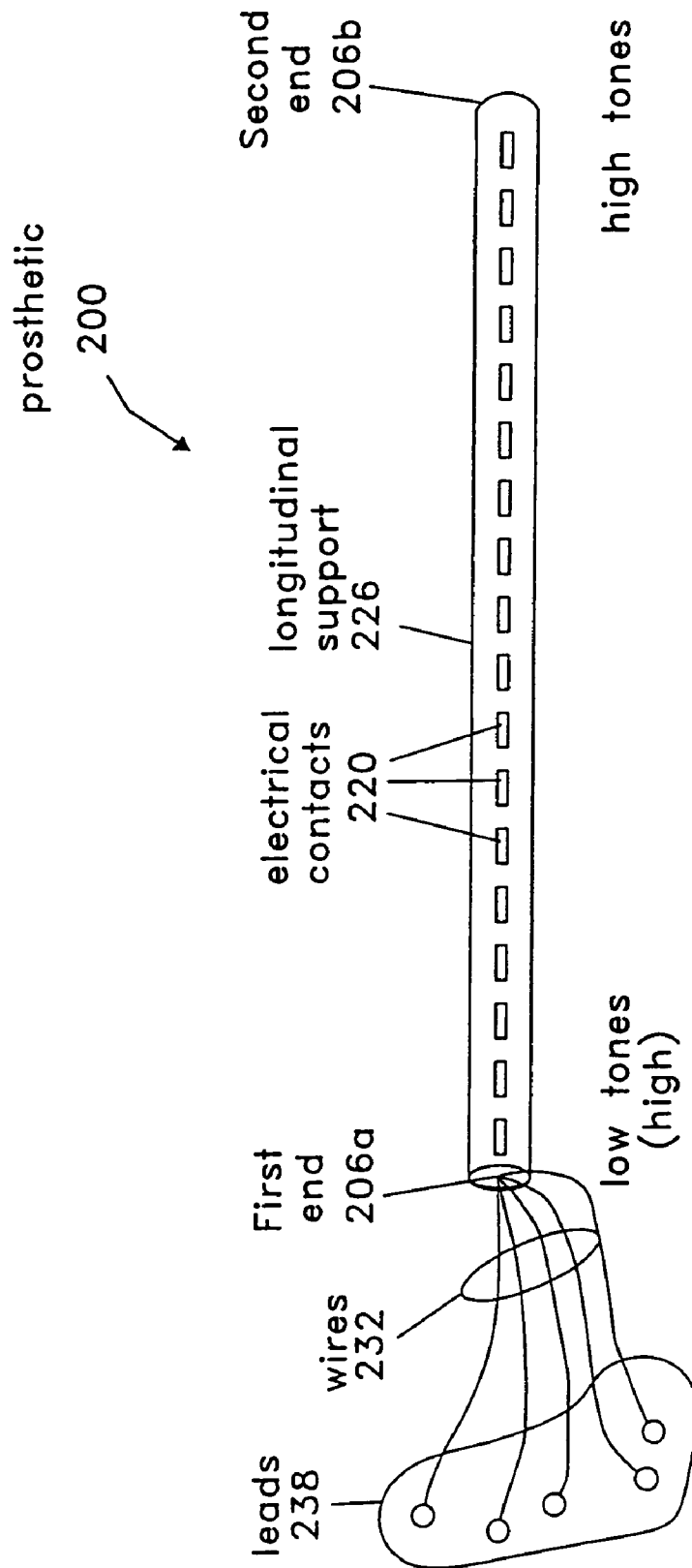

FIG. 2

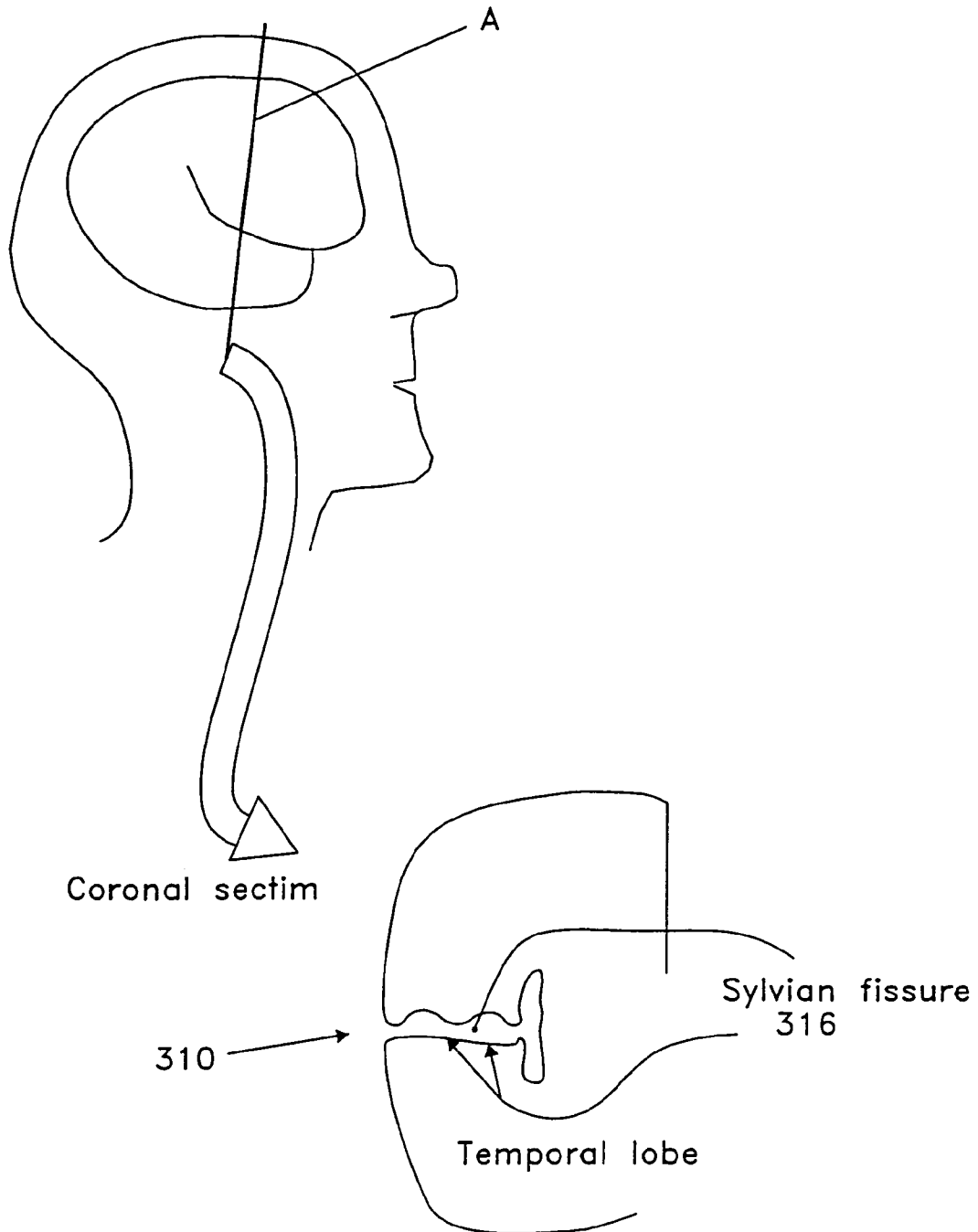

FIG. 3A

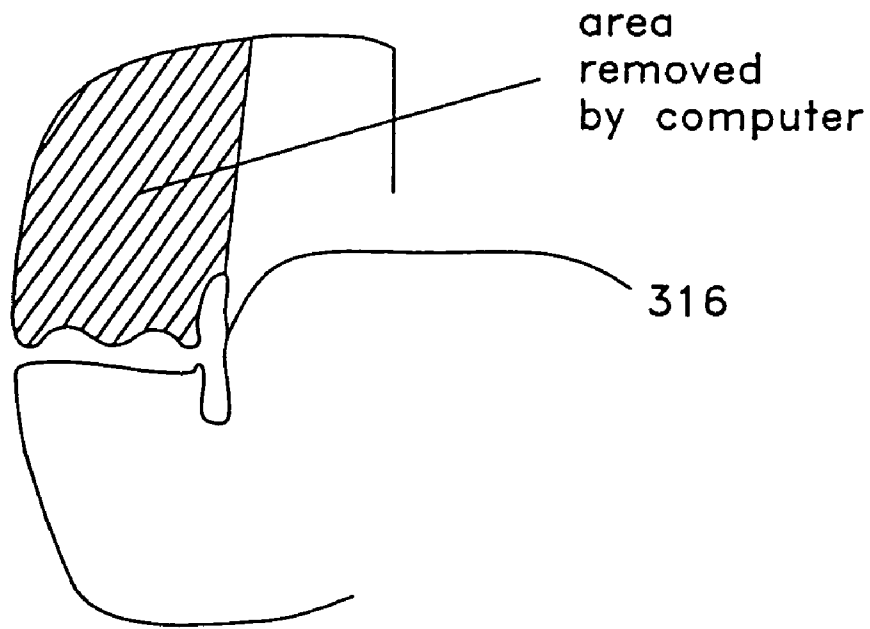

FIG. 3B

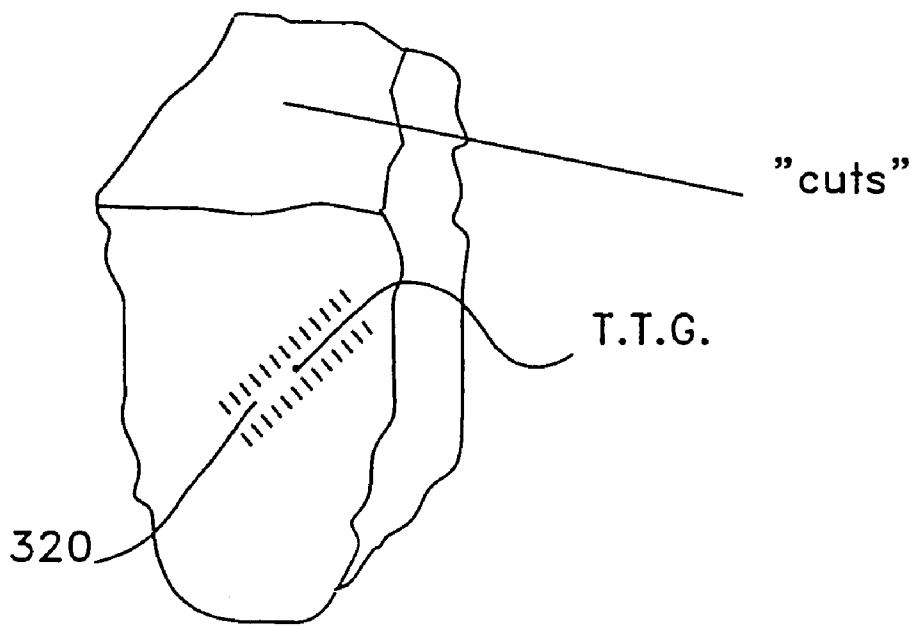

FIG. 3C

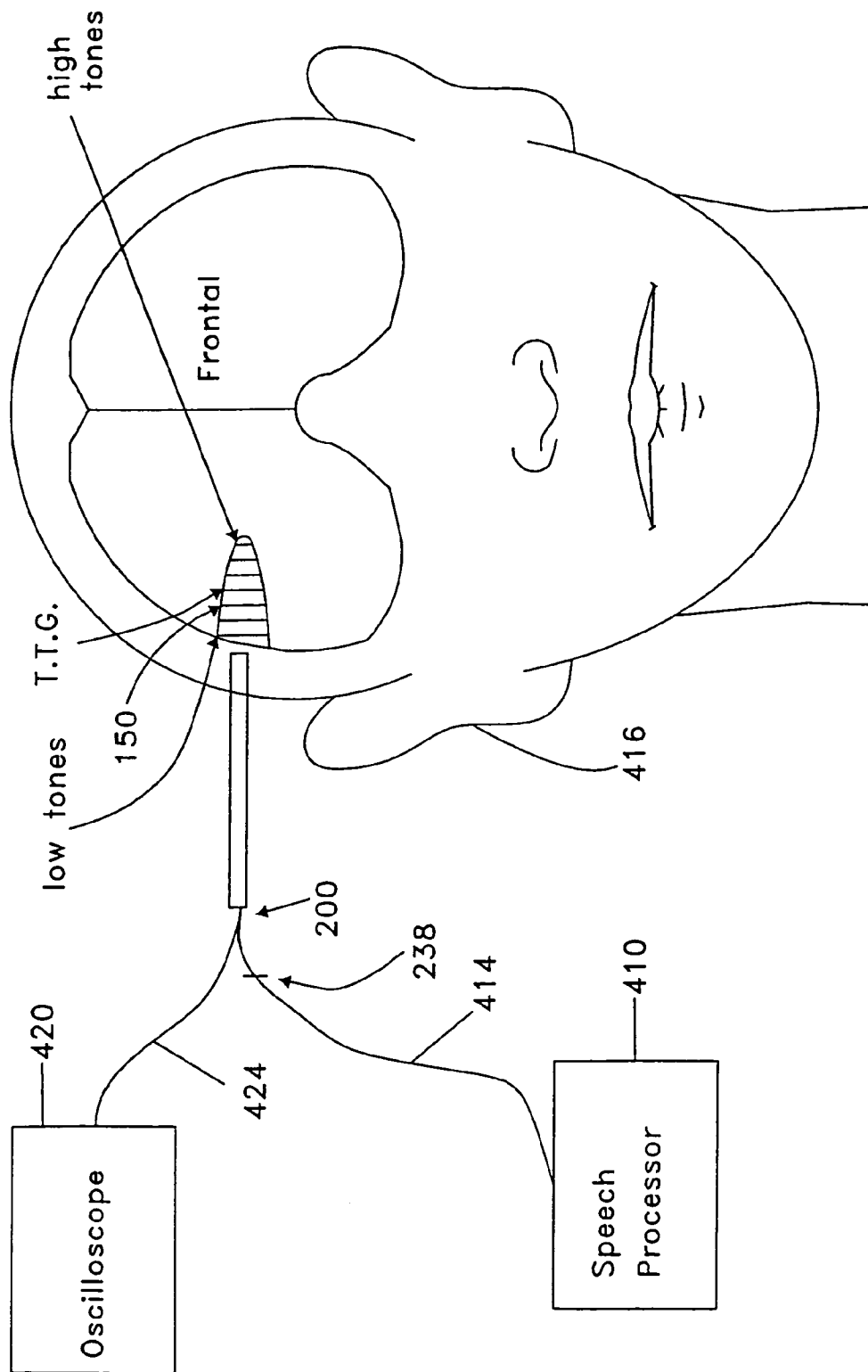

FIG. 4

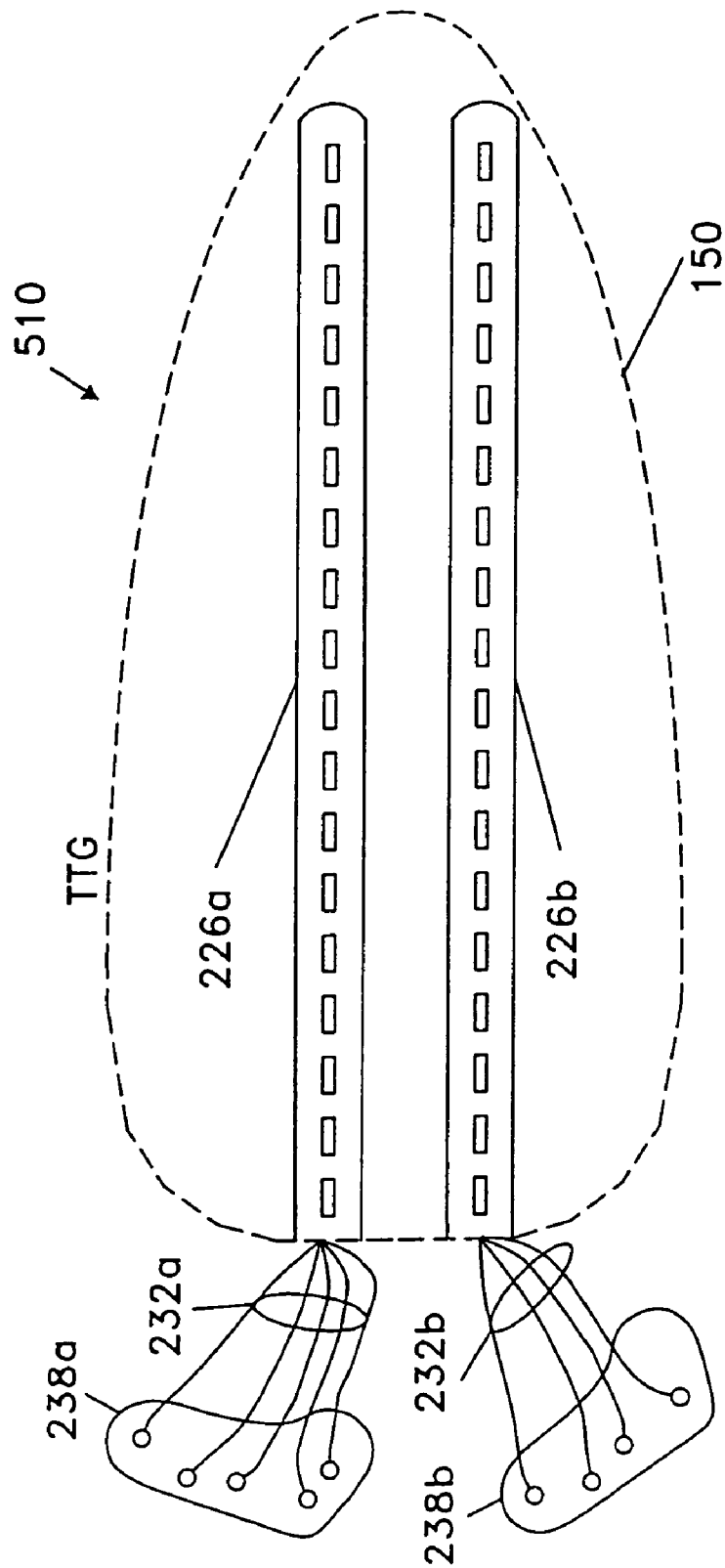

FIG. 5

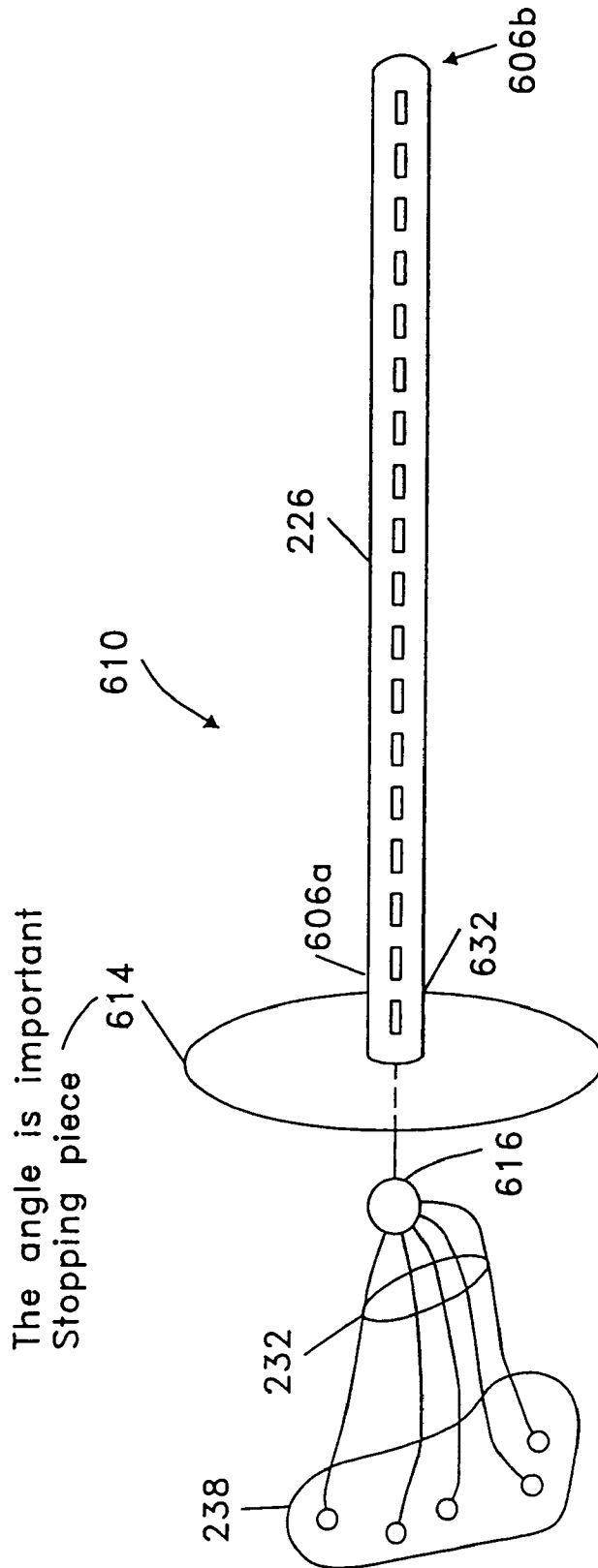

FIG. 6

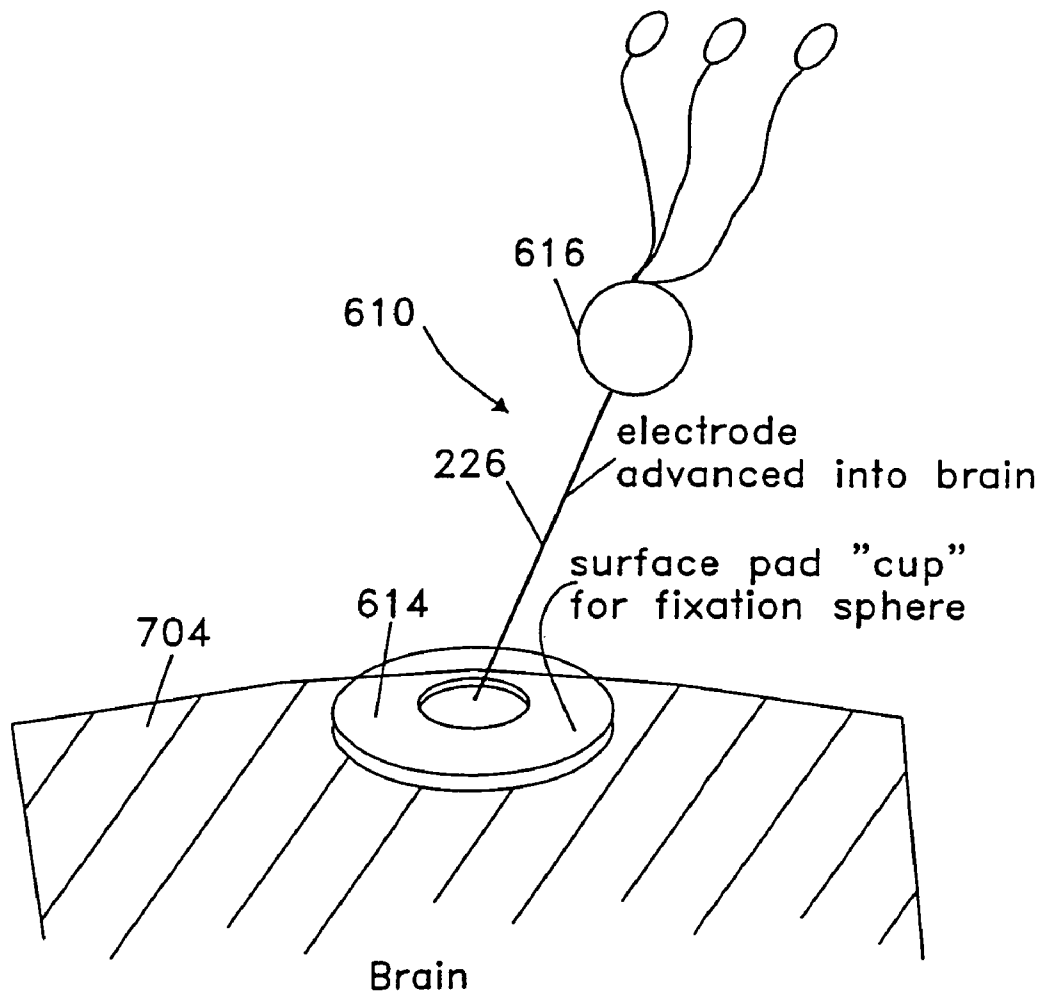

FIG. 7A

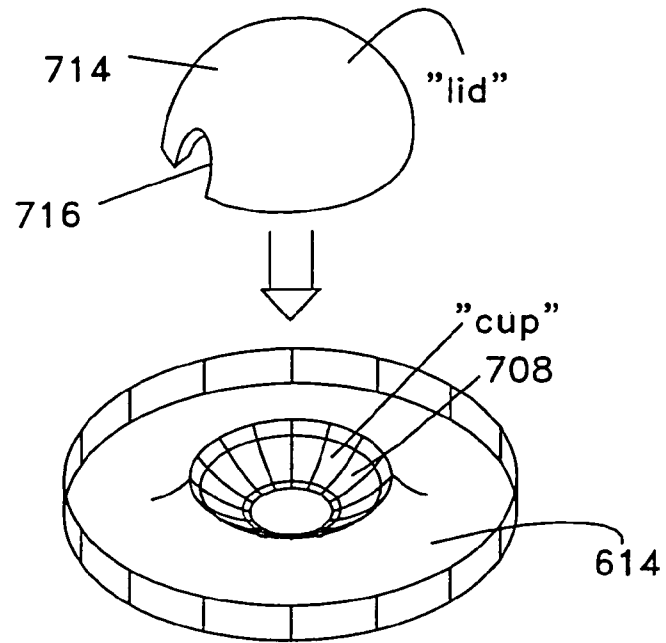

FIG. 7B

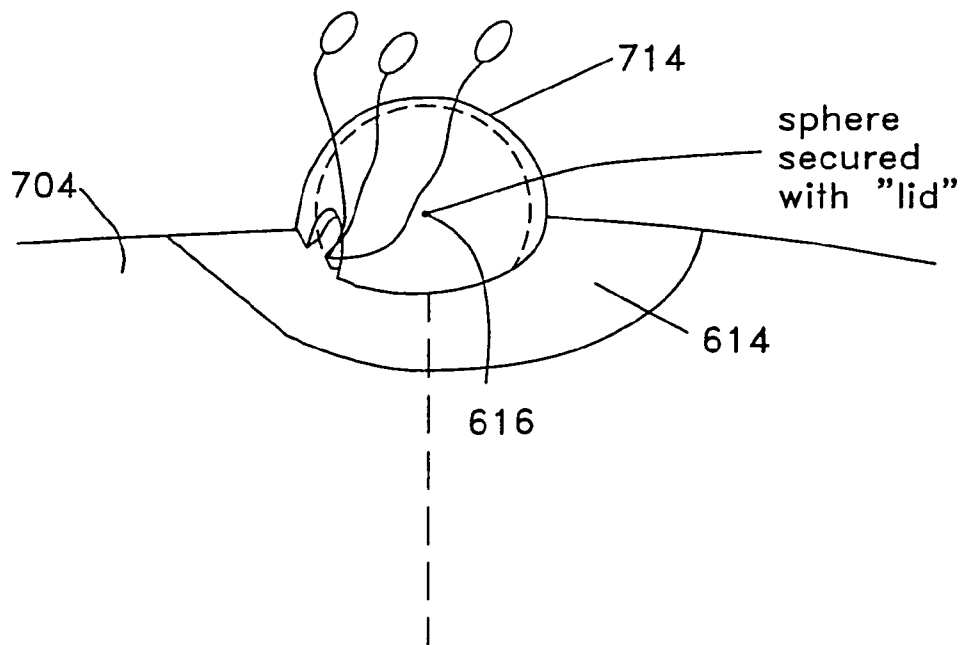

FIG. 7C

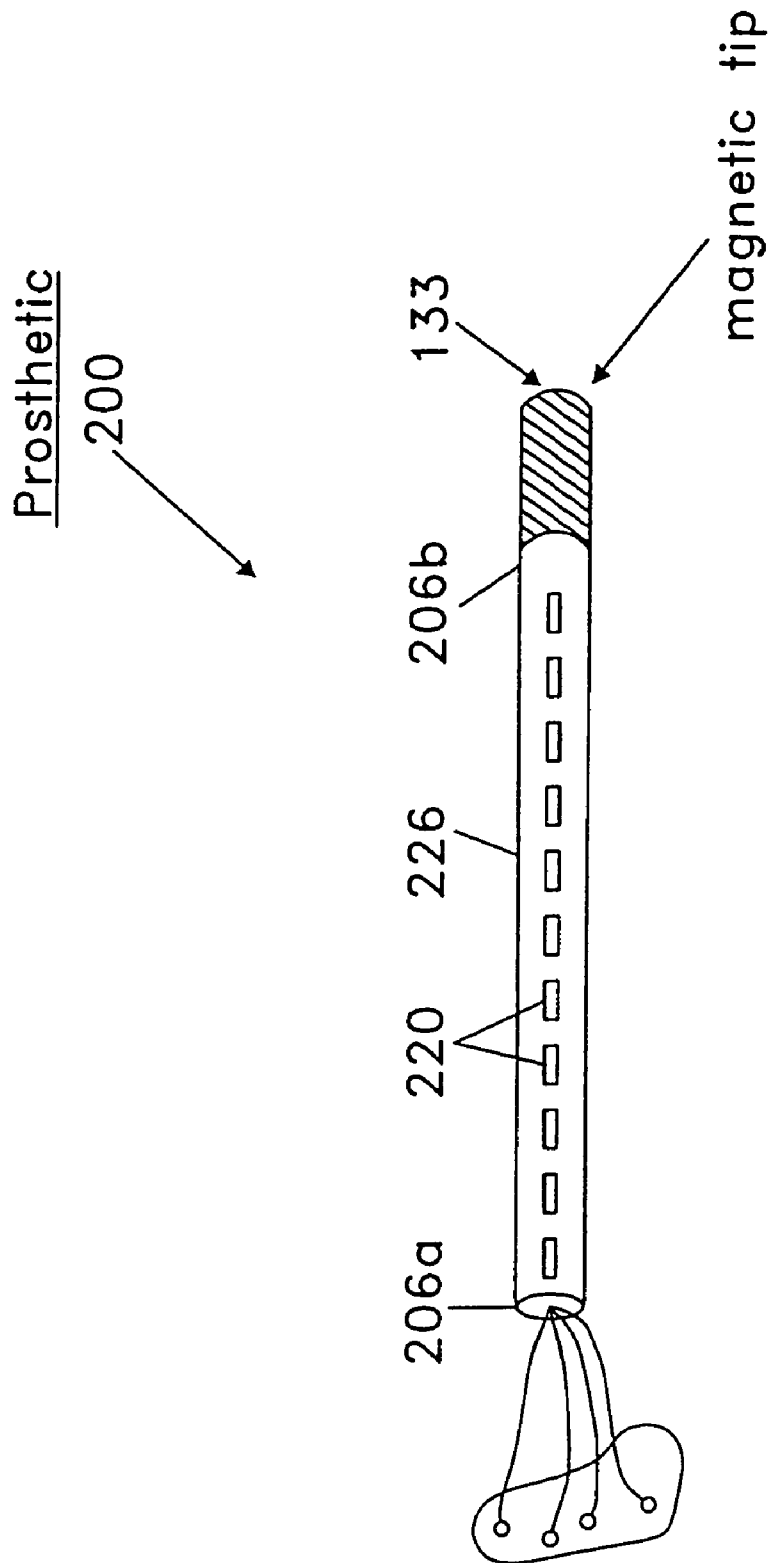

FIG. 8

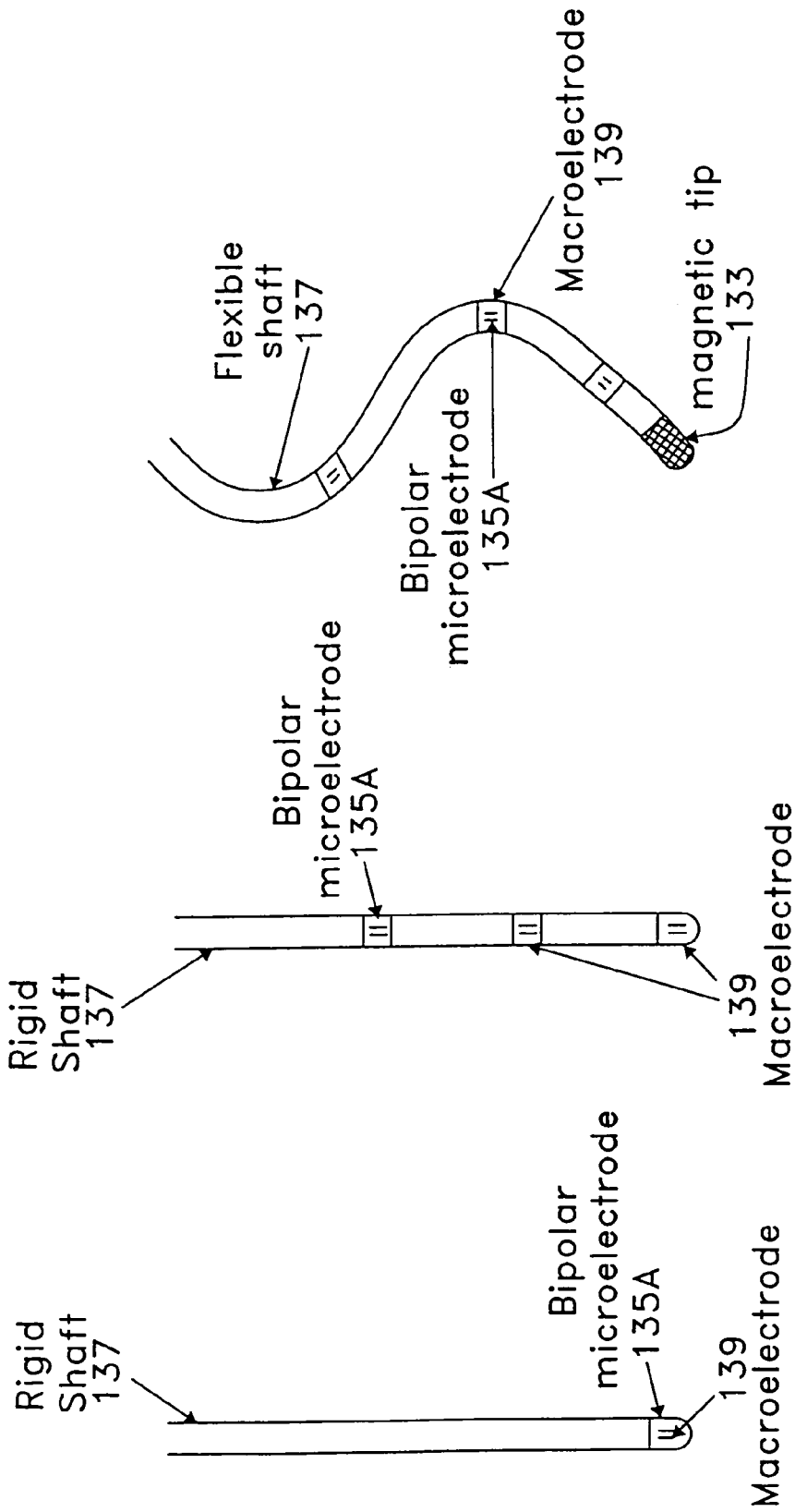

FIG. 9A

FIG. 9B

FIG. 9C

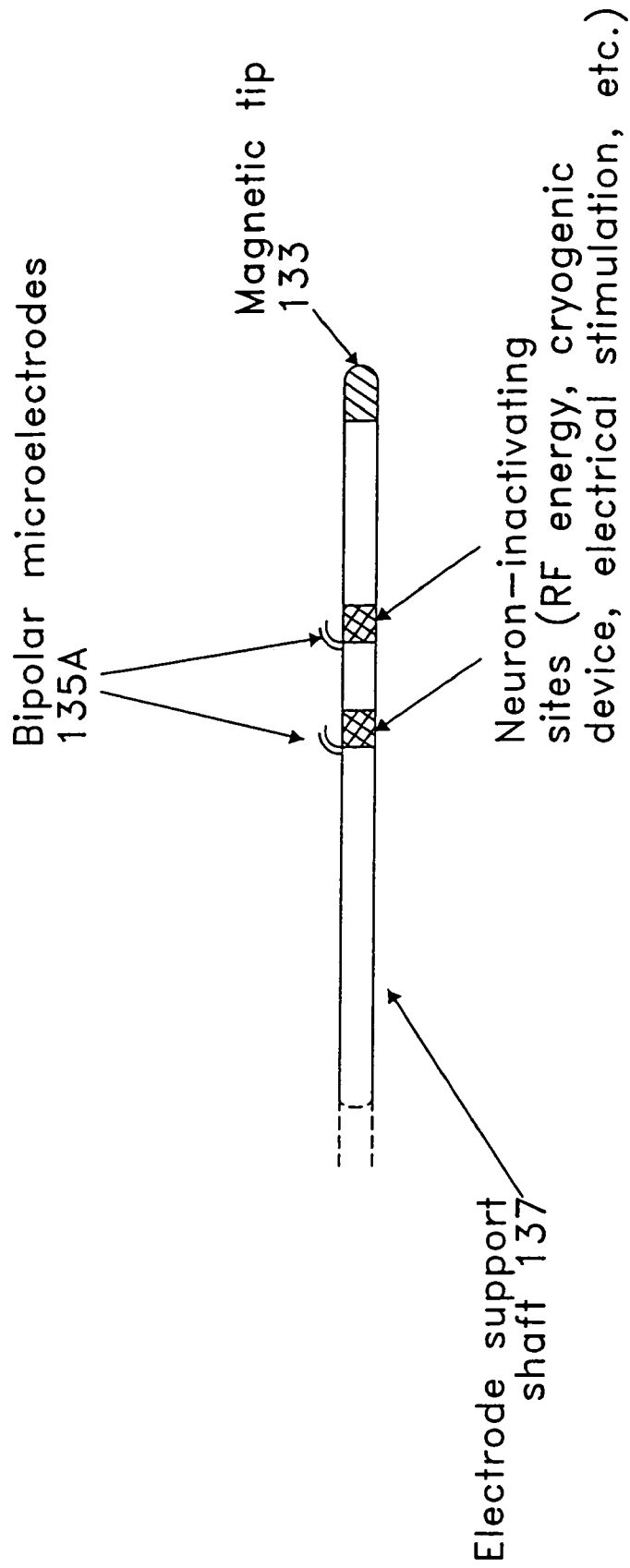

FIG. 10

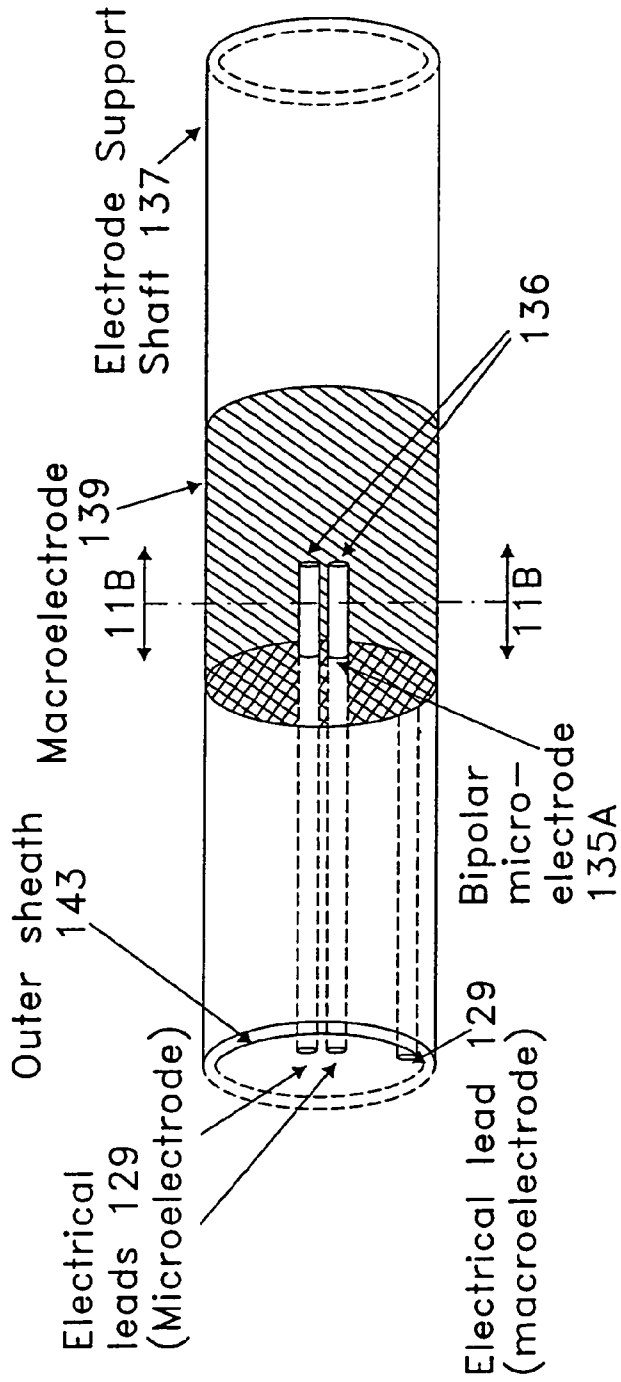

FIG. 11A

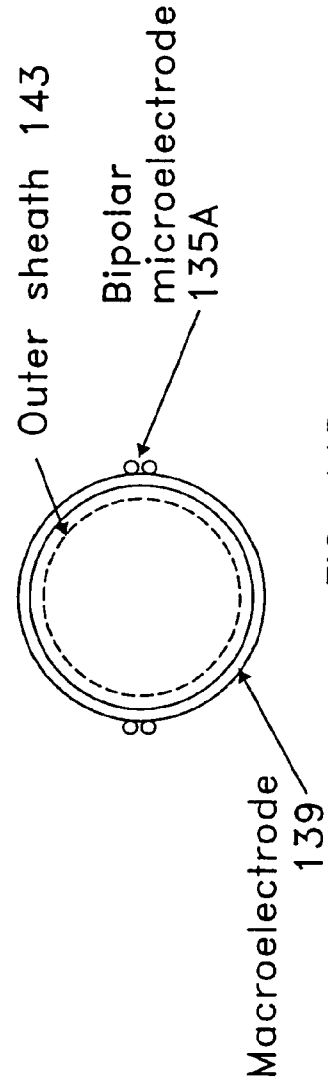

FIG. 11B

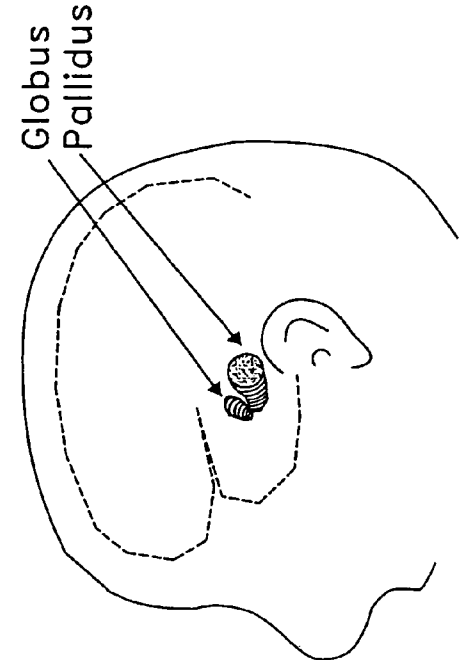

FIG. 12A

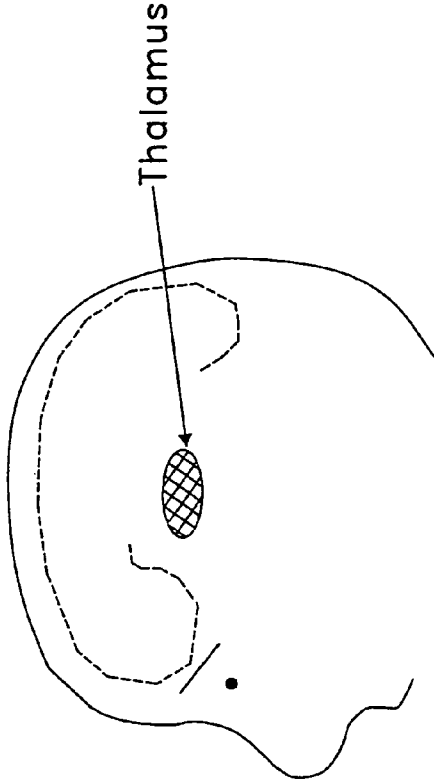
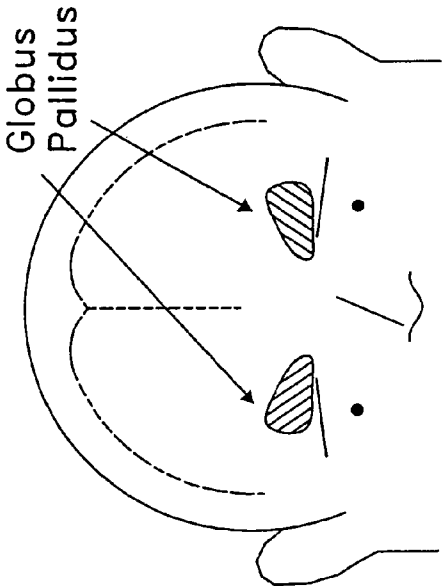

FIG. 12B



Globus
Pallidus

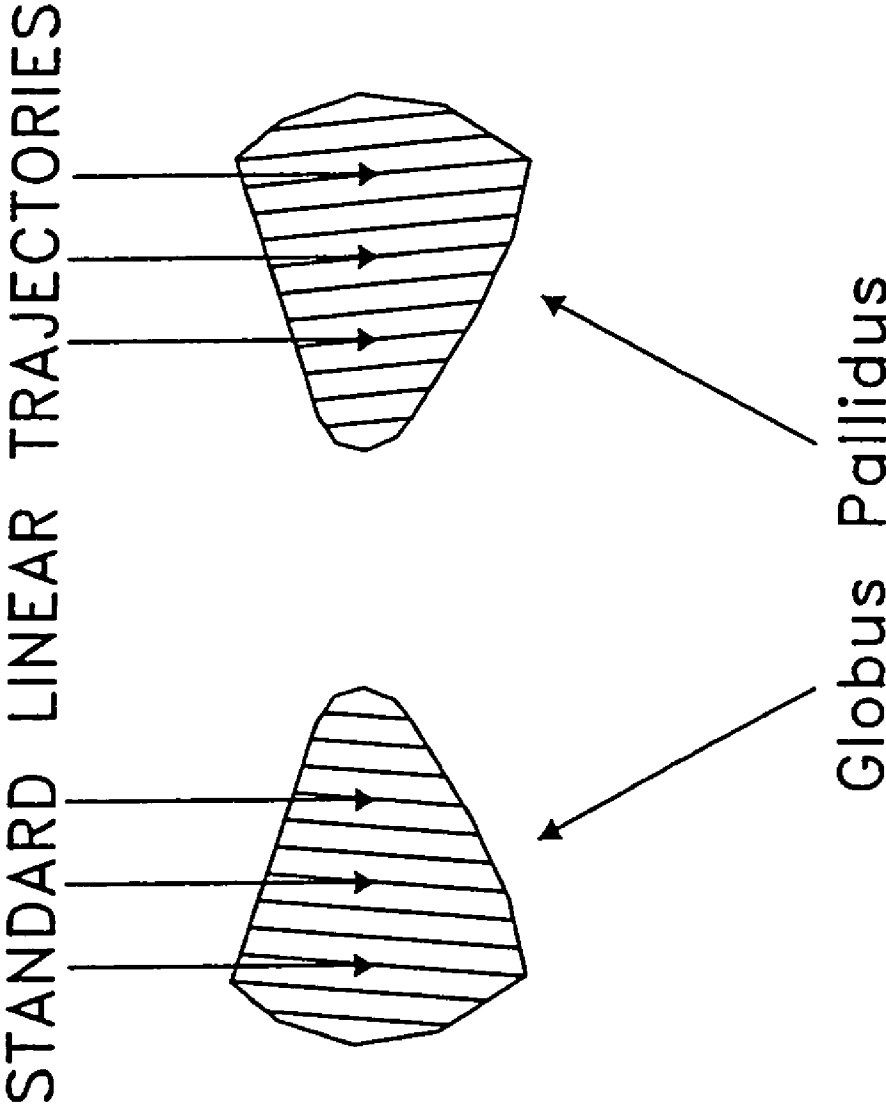

FIG. 12C

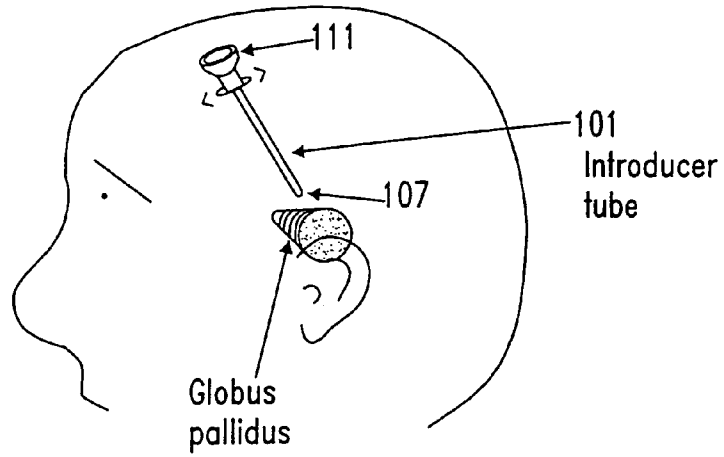

FIG. 13A

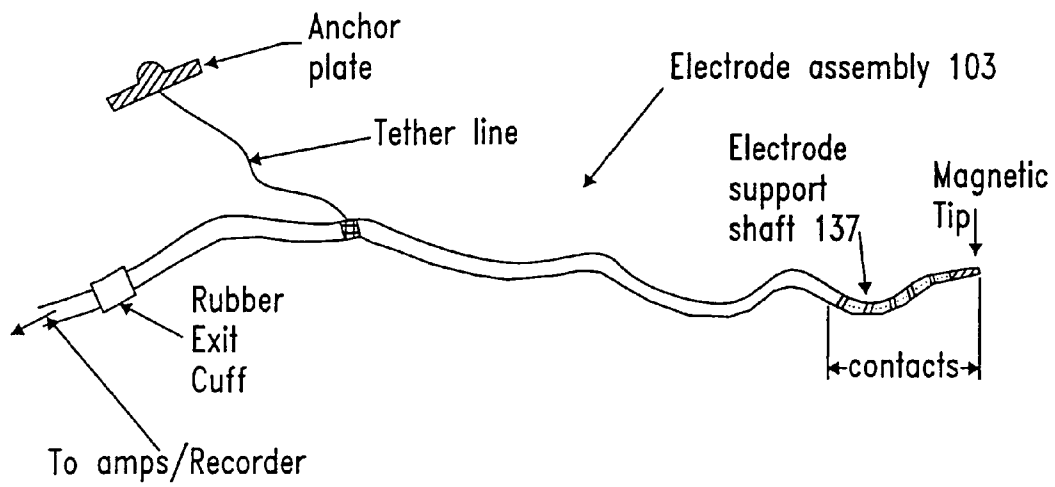

FIG. 13B

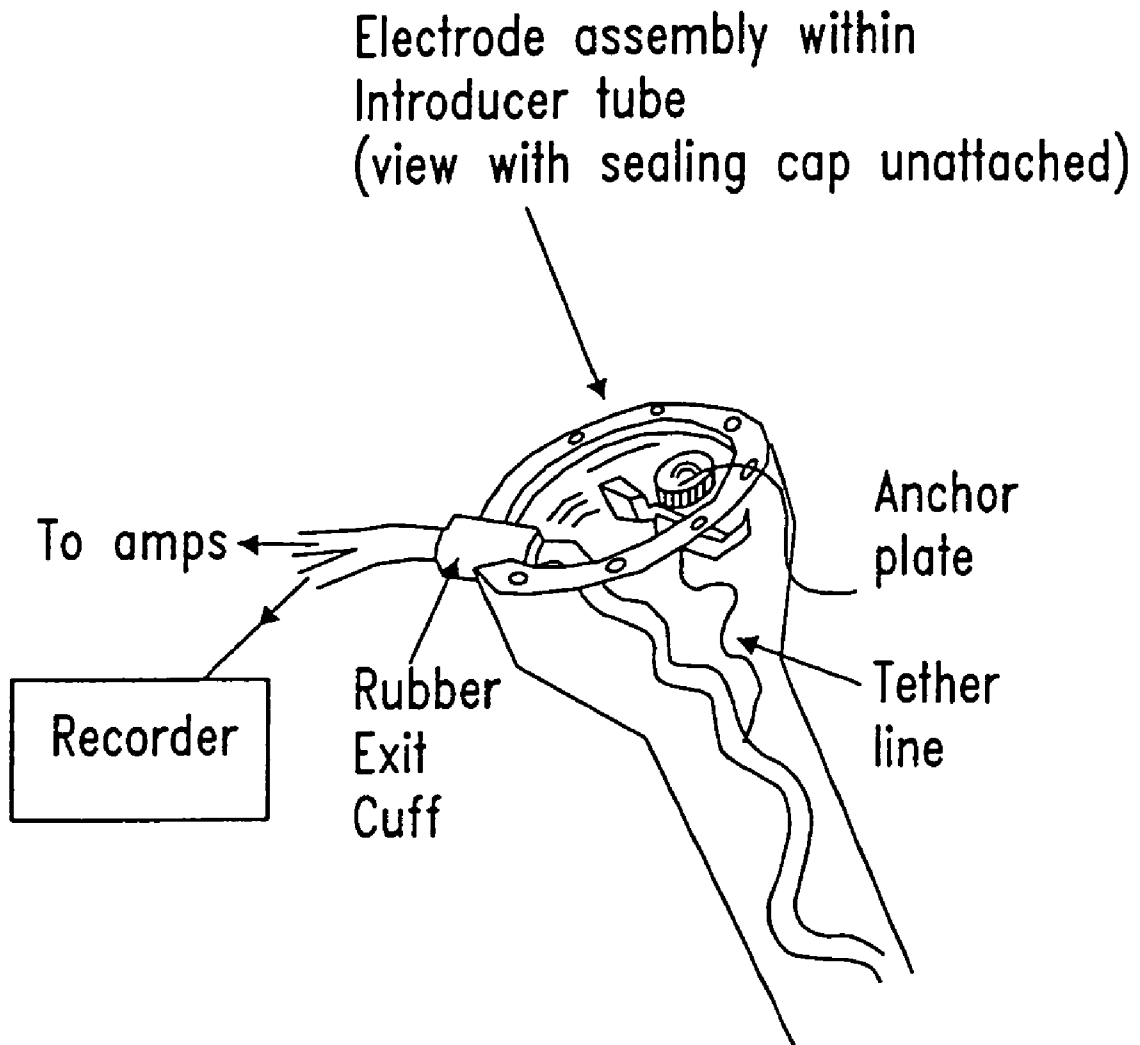

FIG. 13C

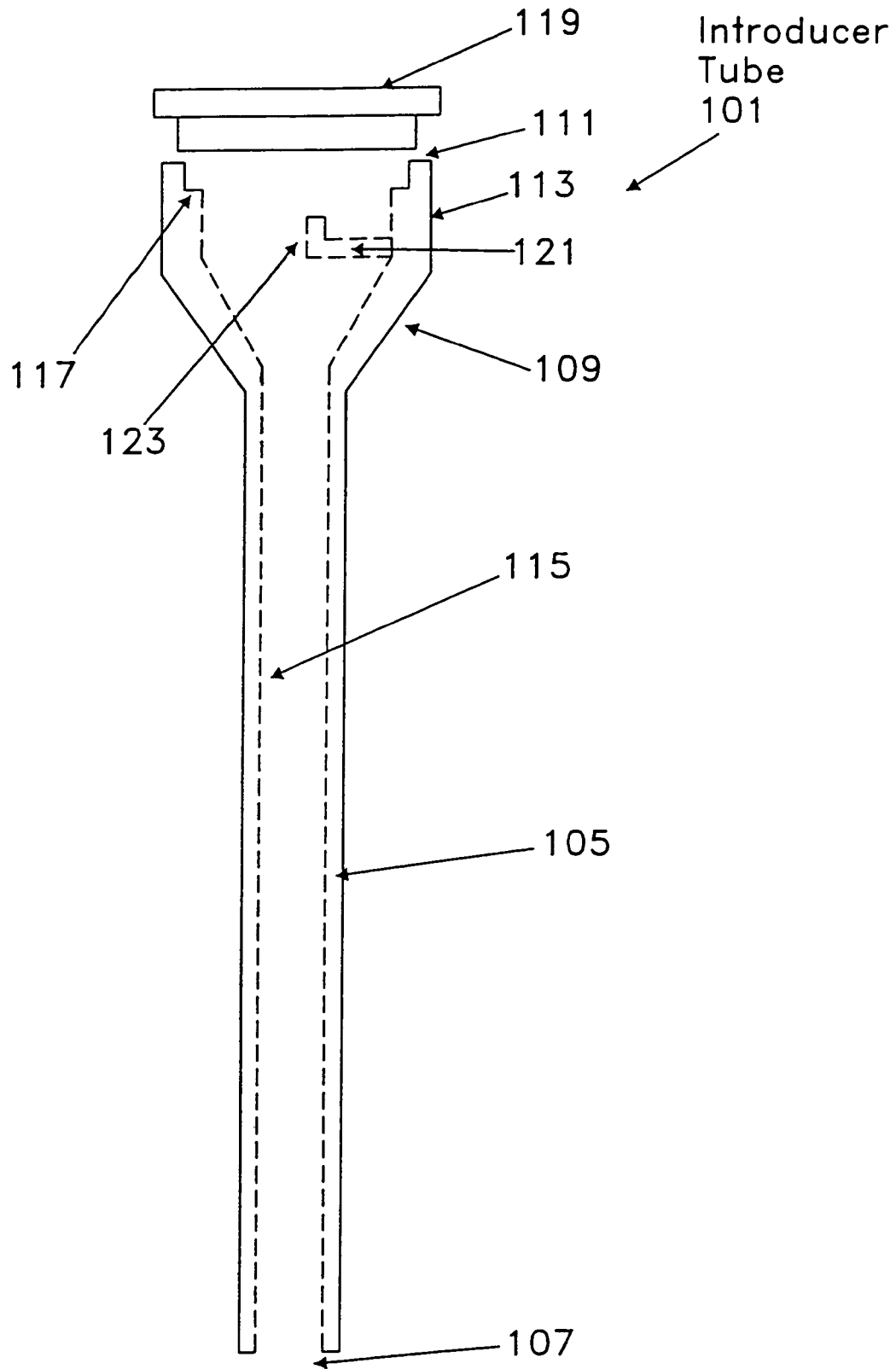

FIG. 14

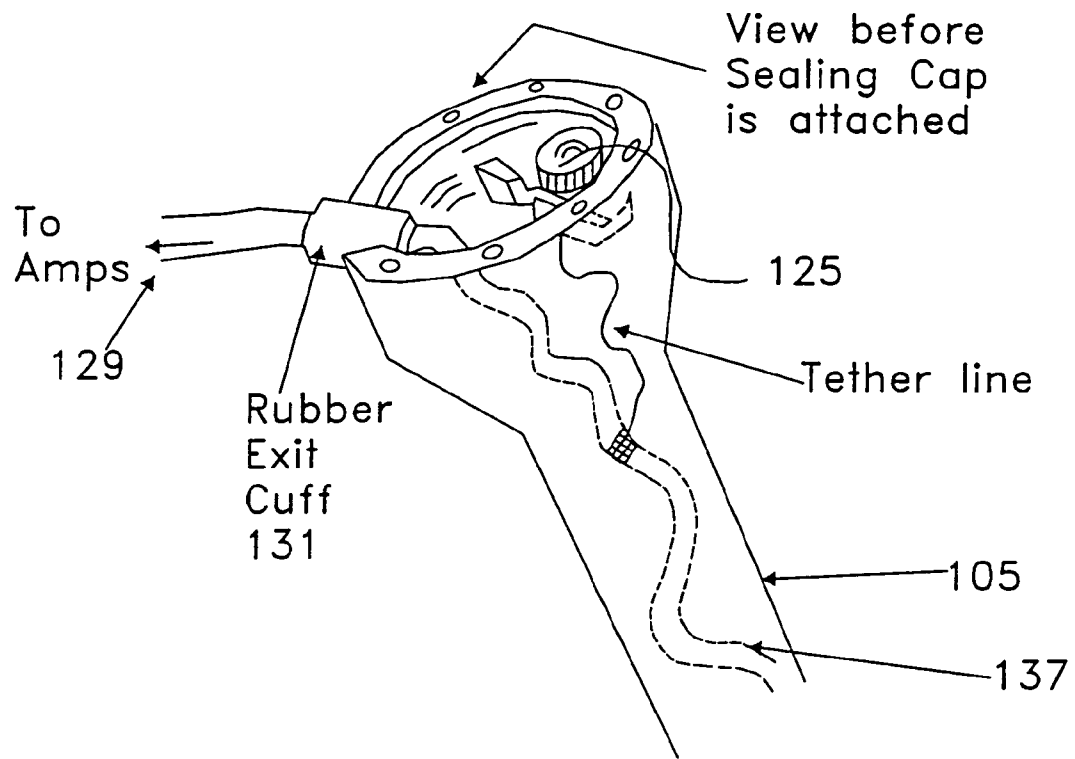

FIG. 15

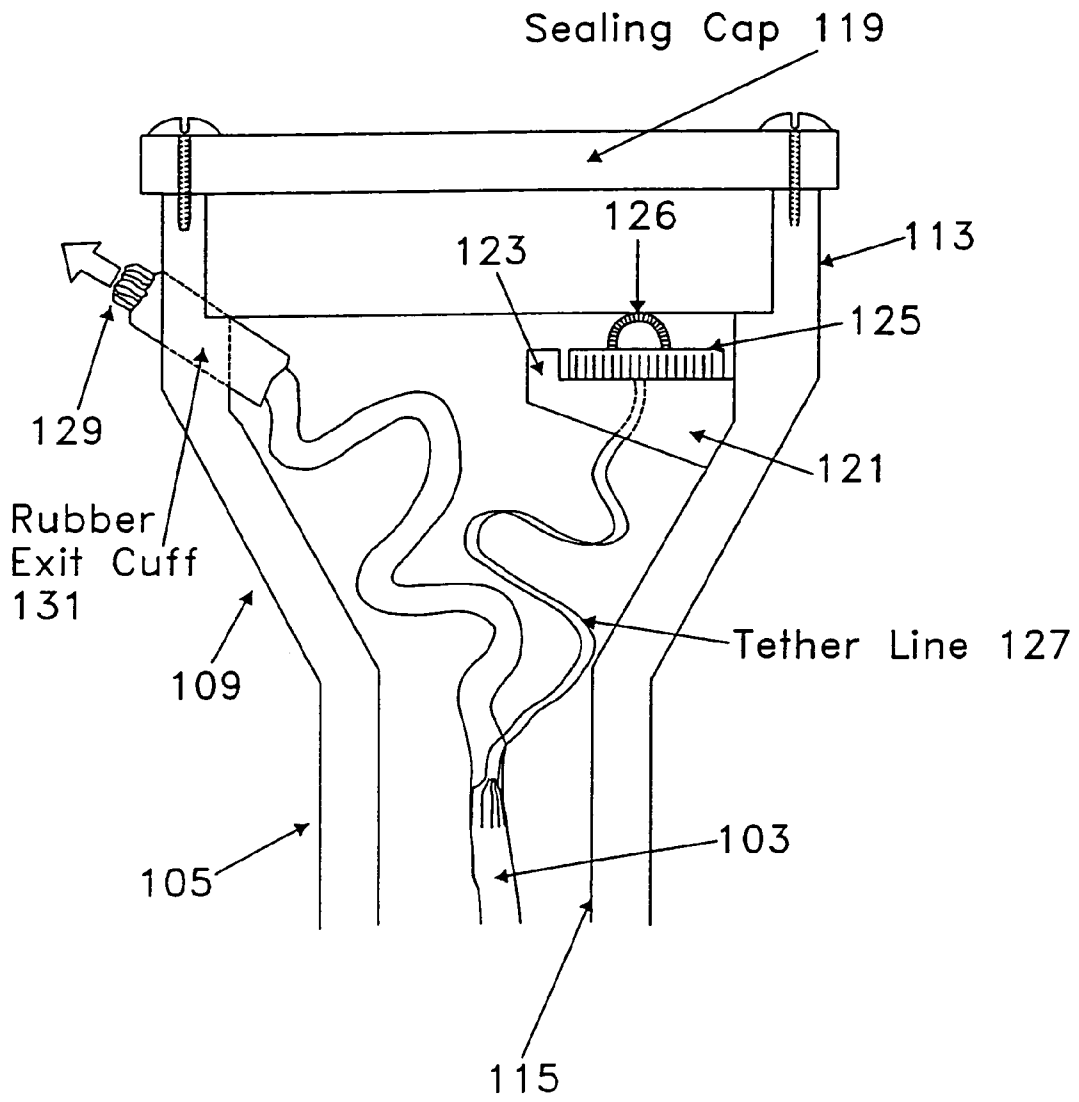

FIG. 16

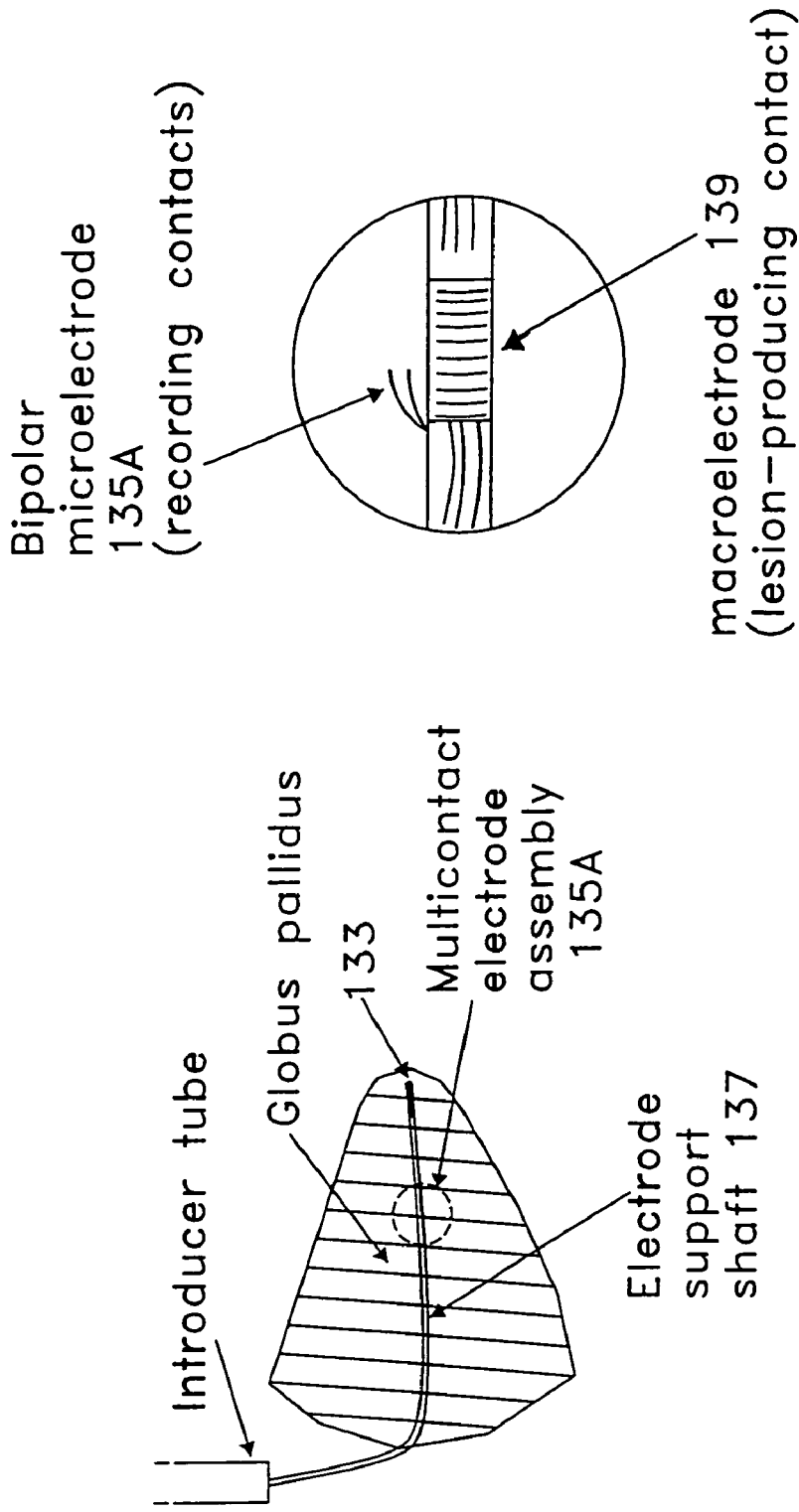

FIG. 17

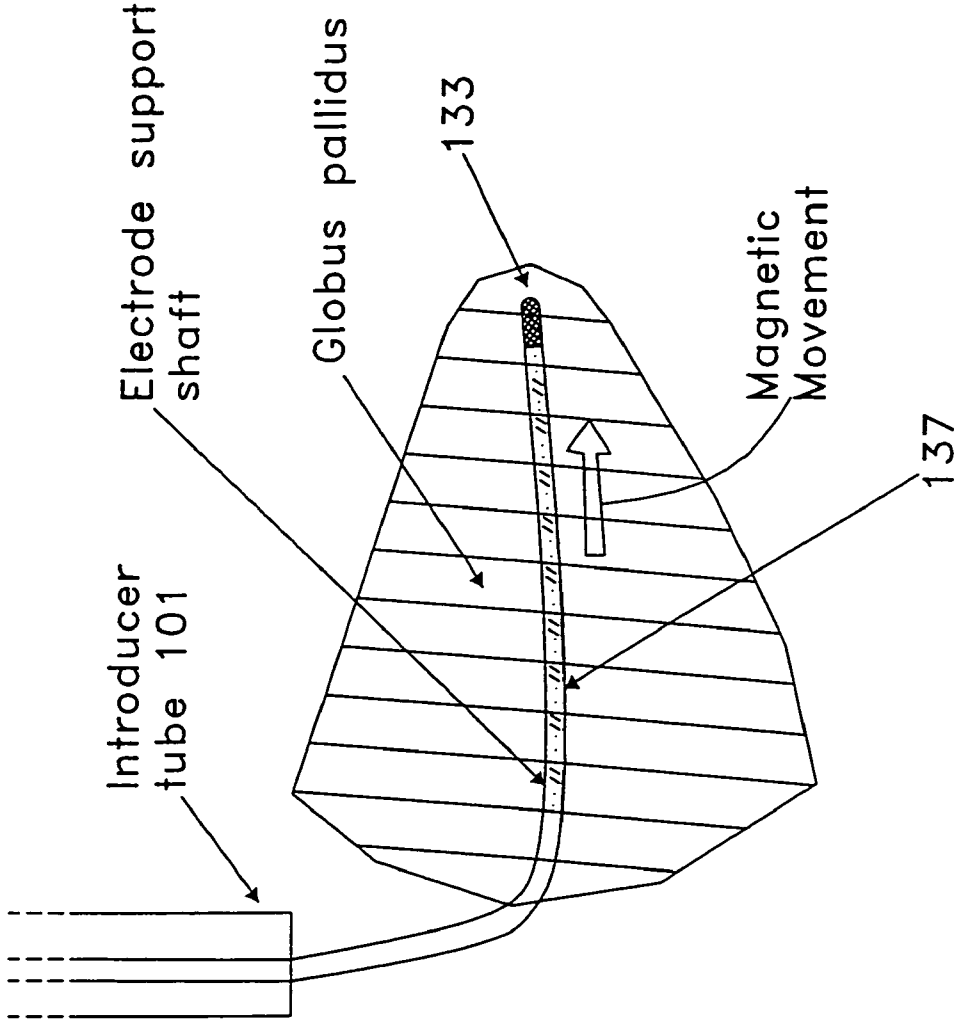

FIG. 18

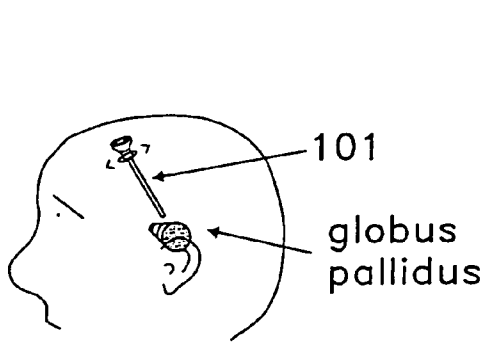

FIG. 19a

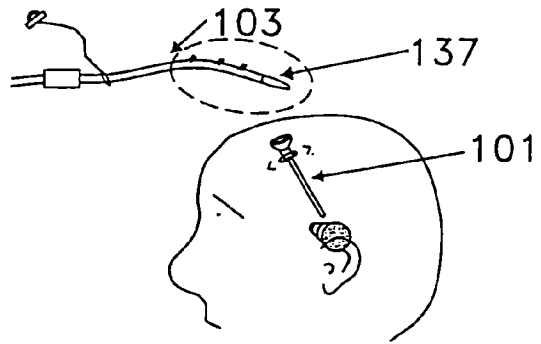

FIG. 19b

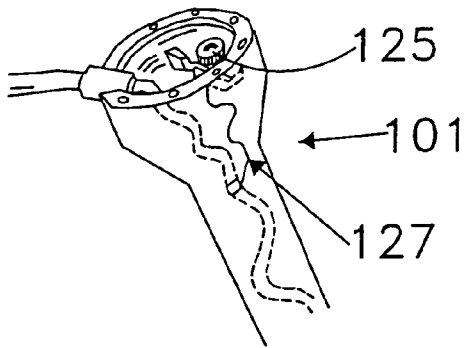

FIG. 19c

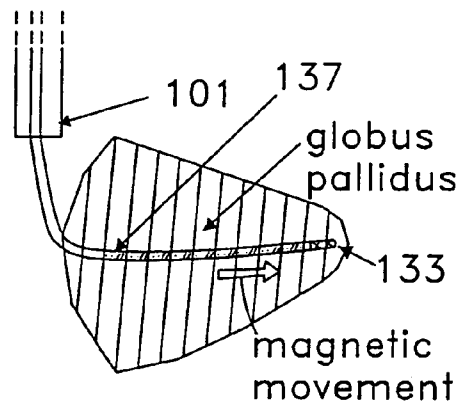
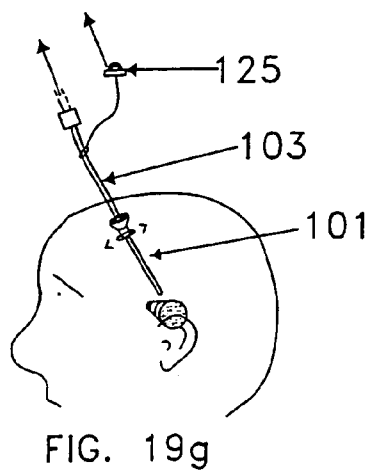
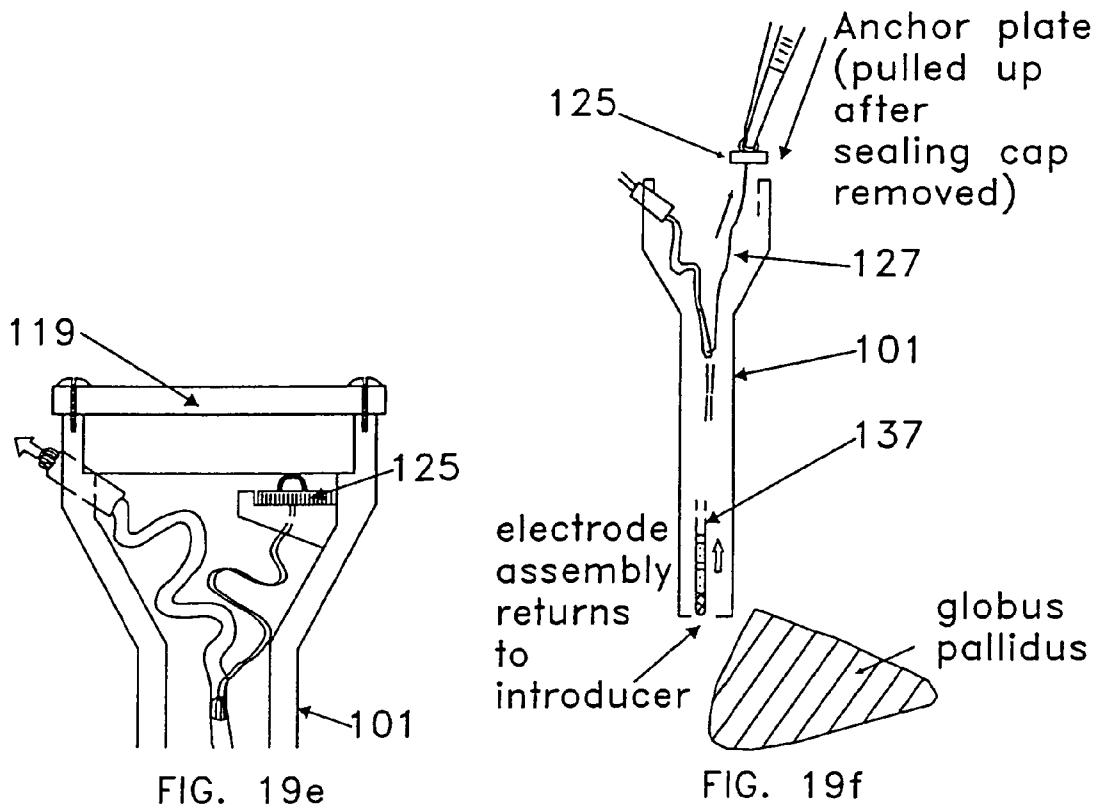

FIG. 19d



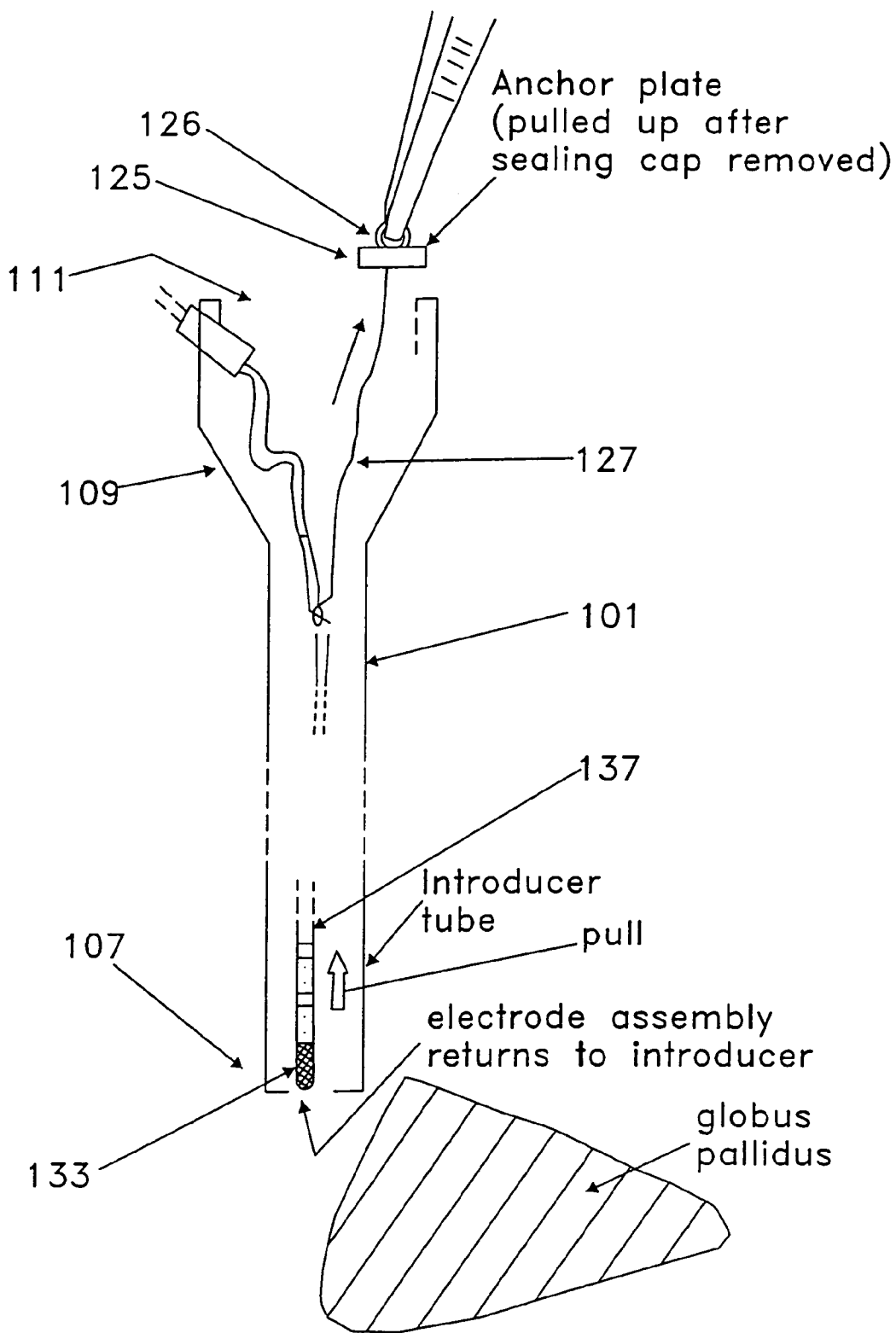
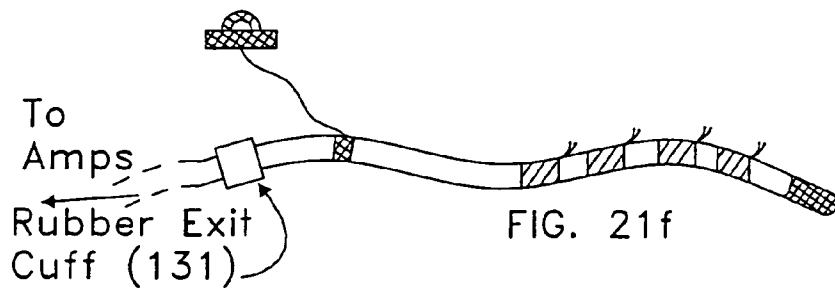
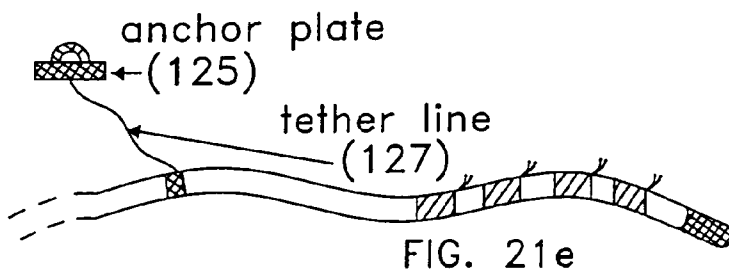
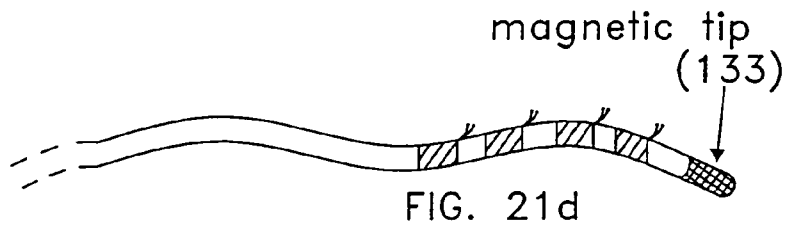
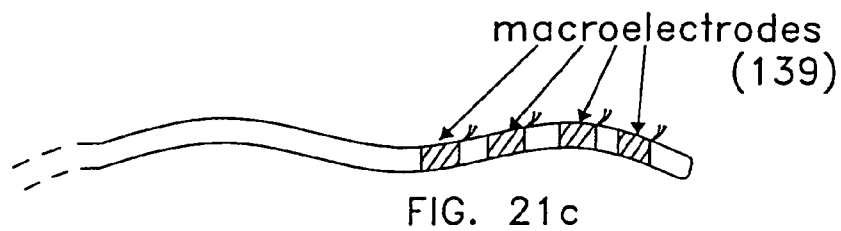
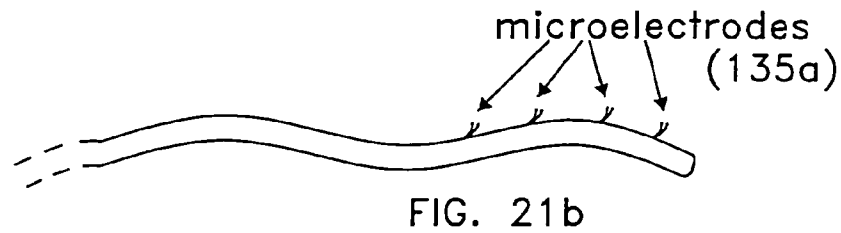
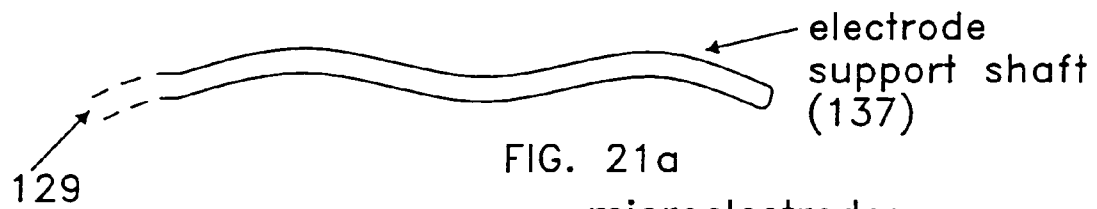

FIG. 20



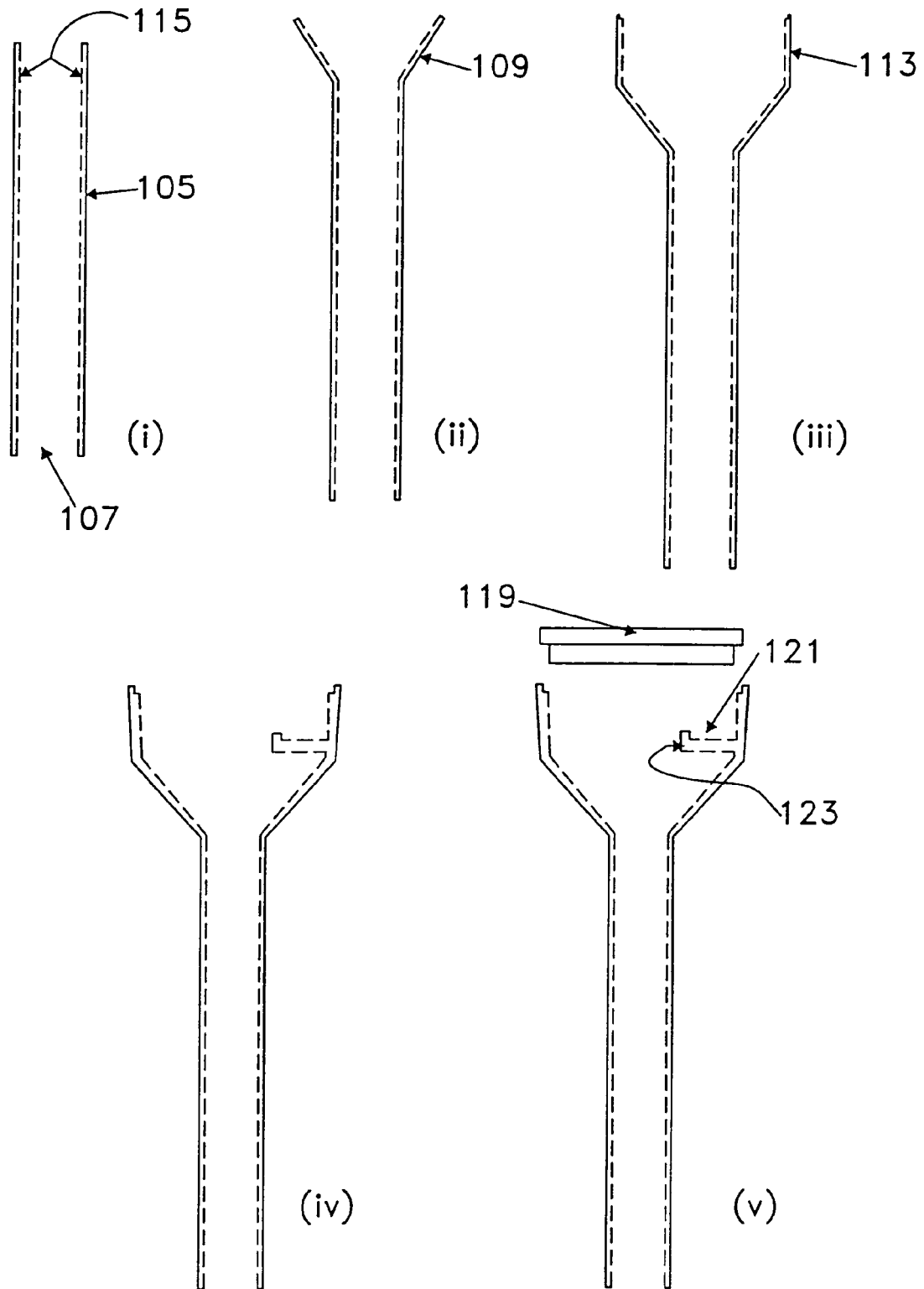

FIG. 22

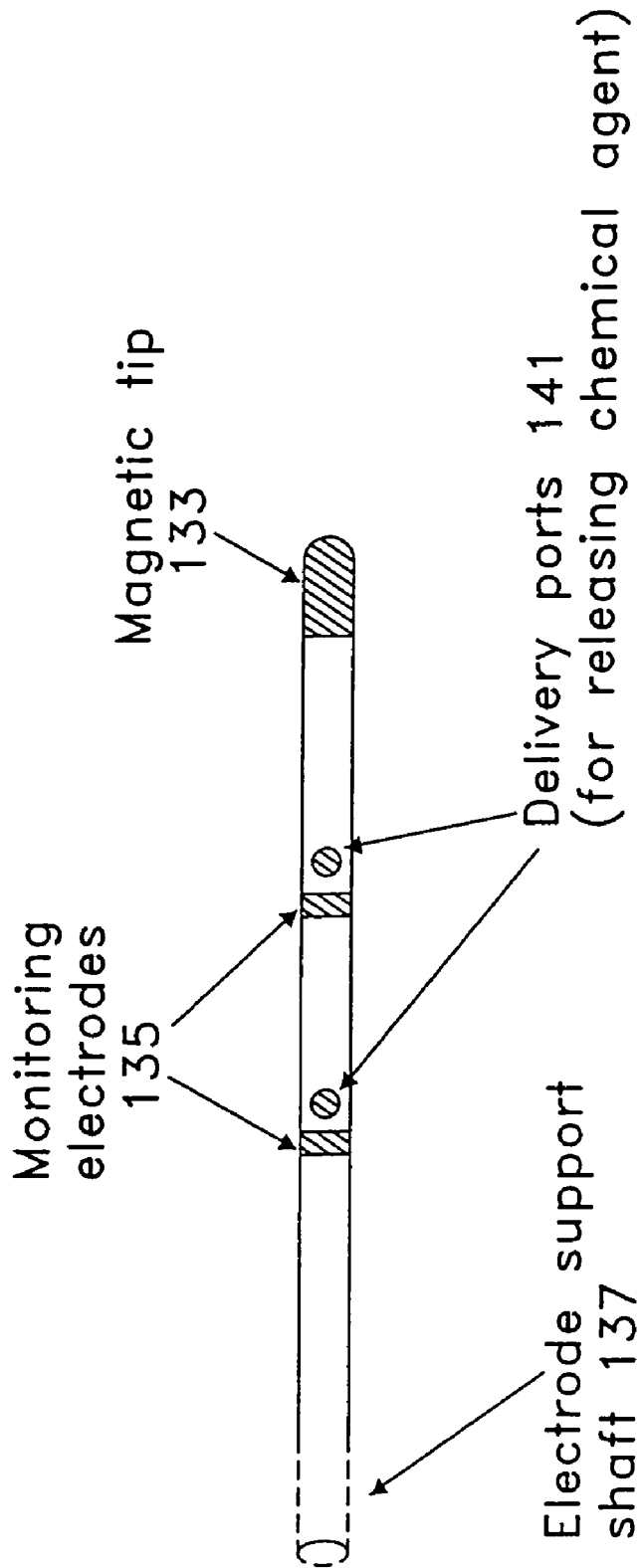

FIG. 23

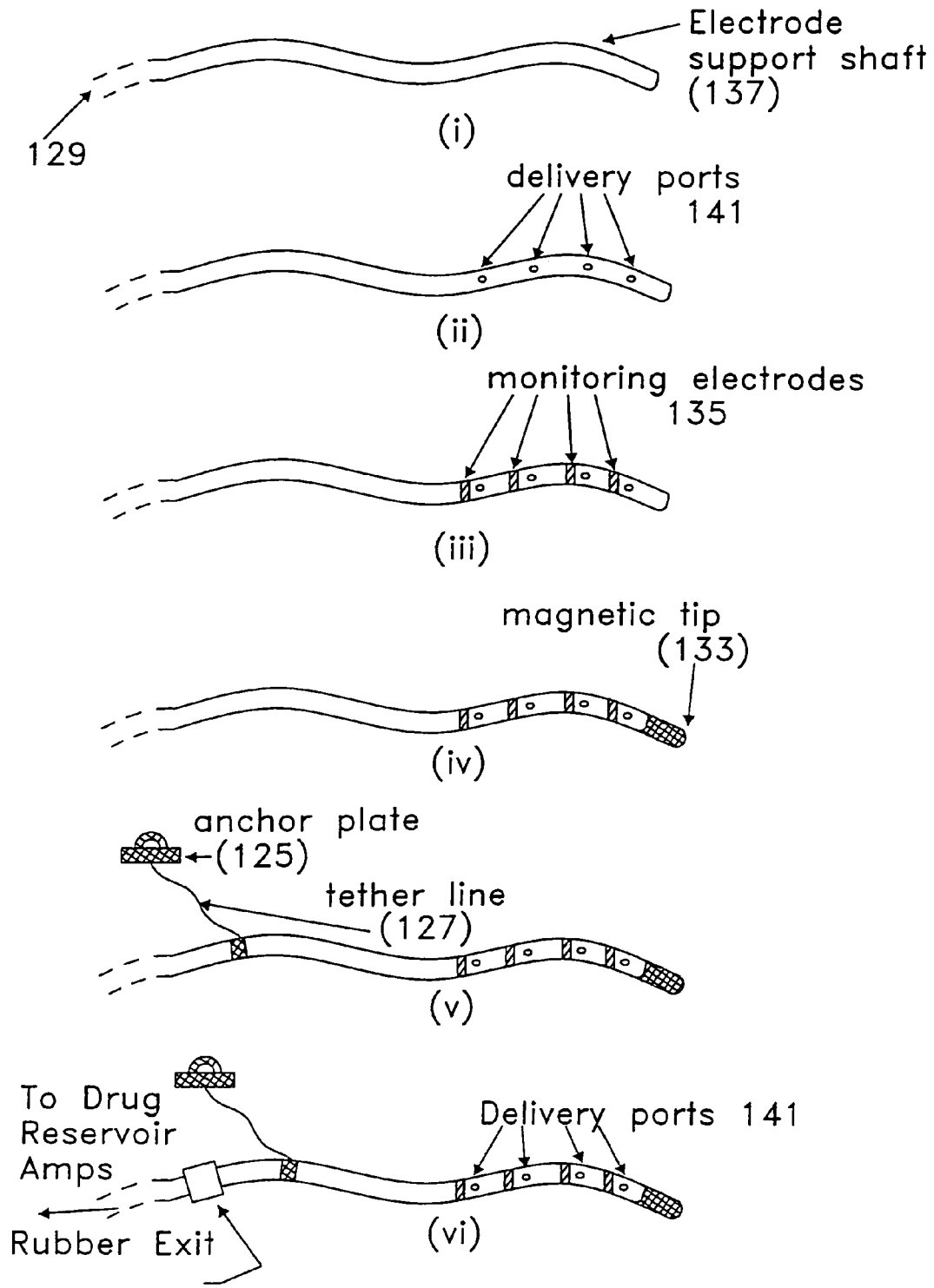

FIG. 24

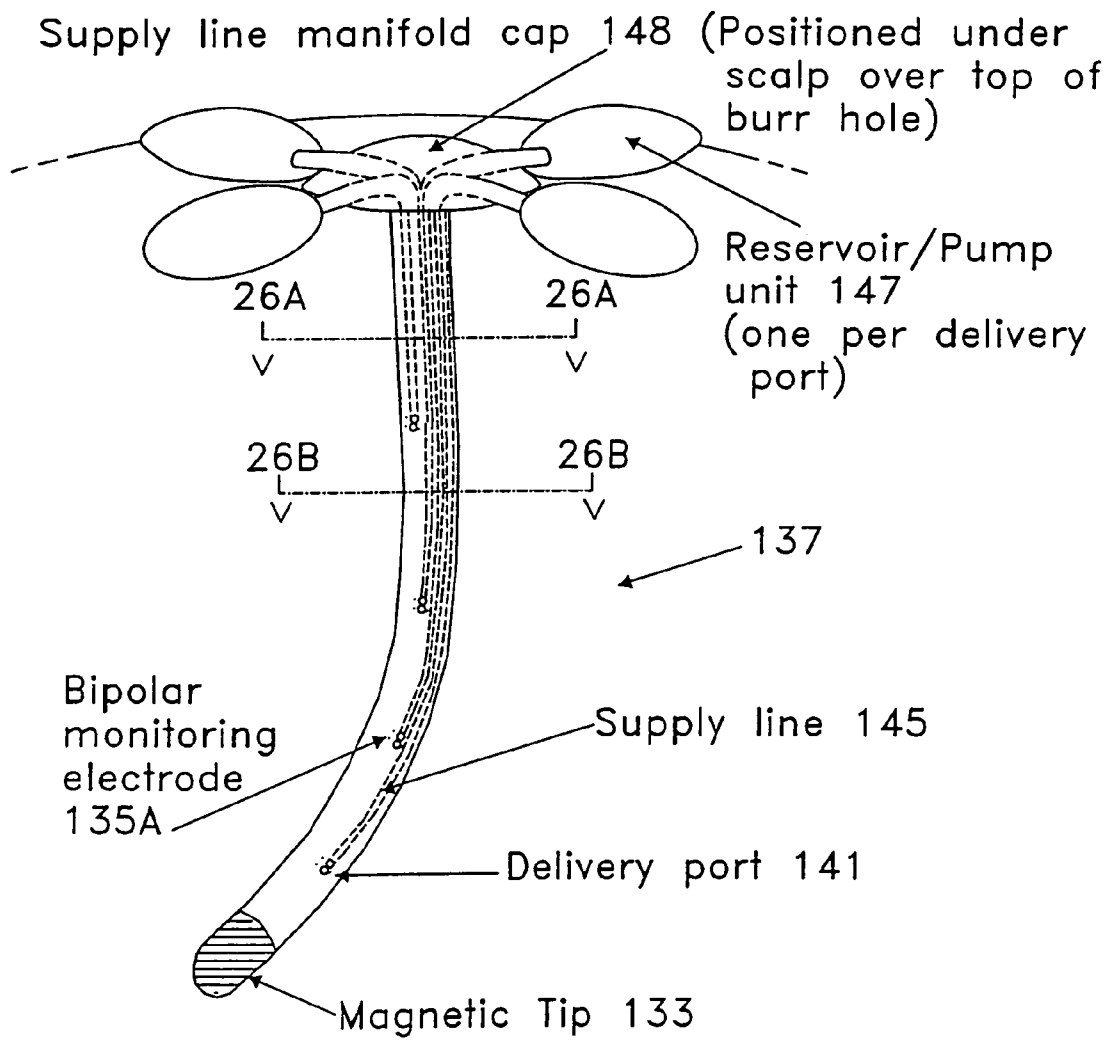

FIG. 25

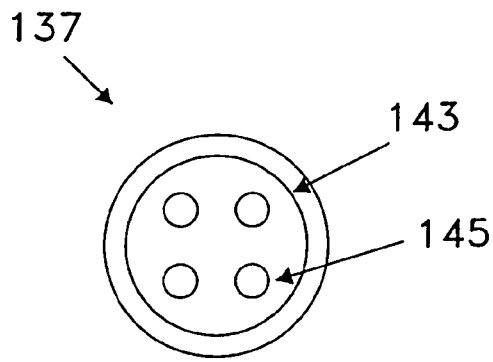

FIG. 26A

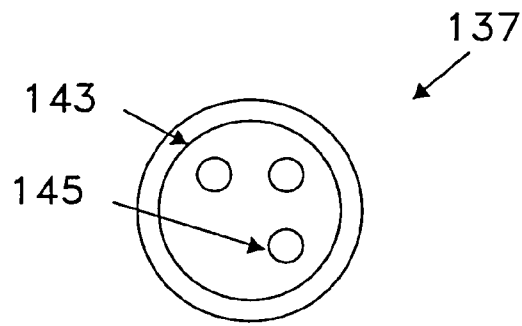

FIG. 26B

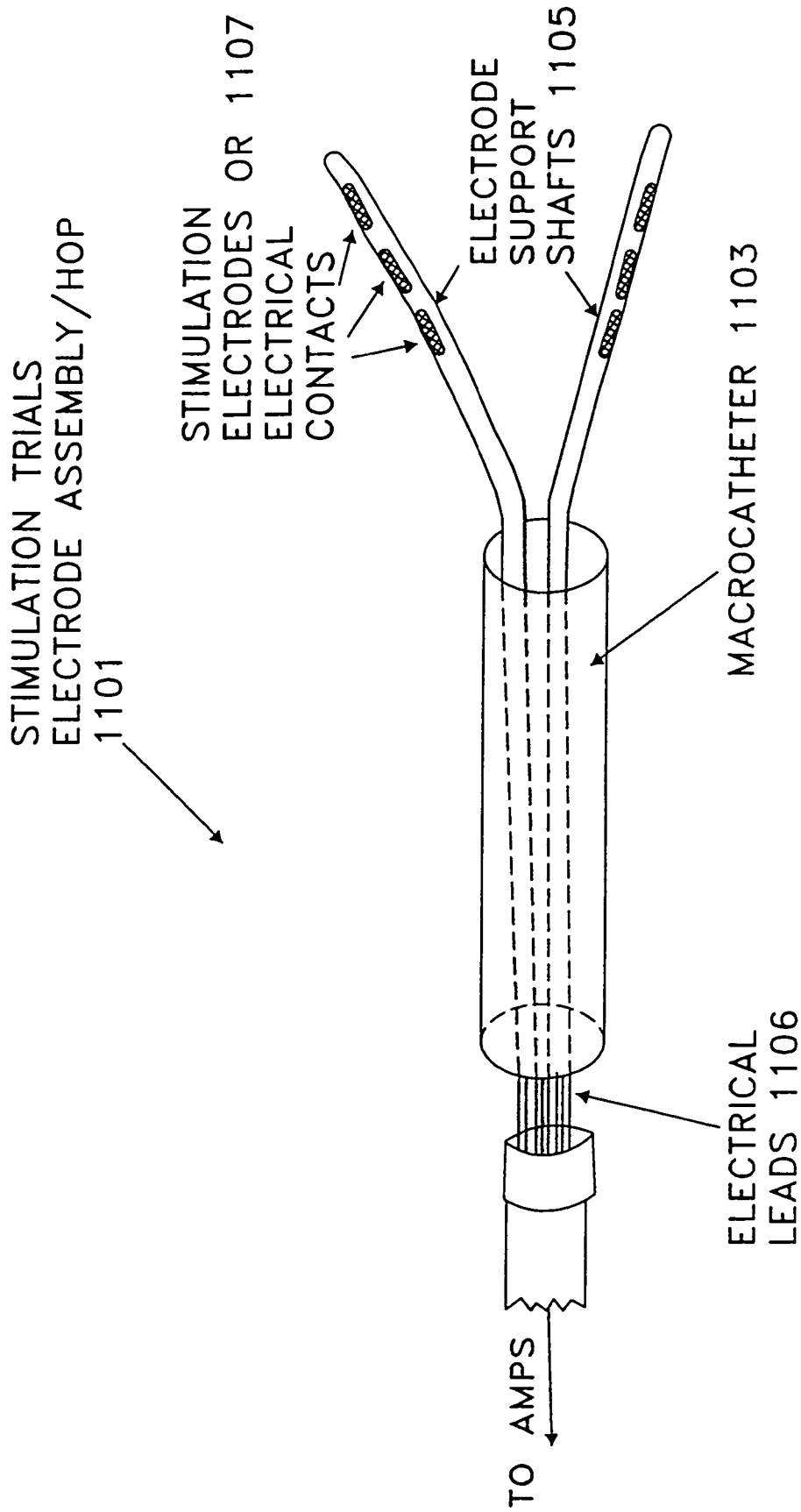

FIG. 27A

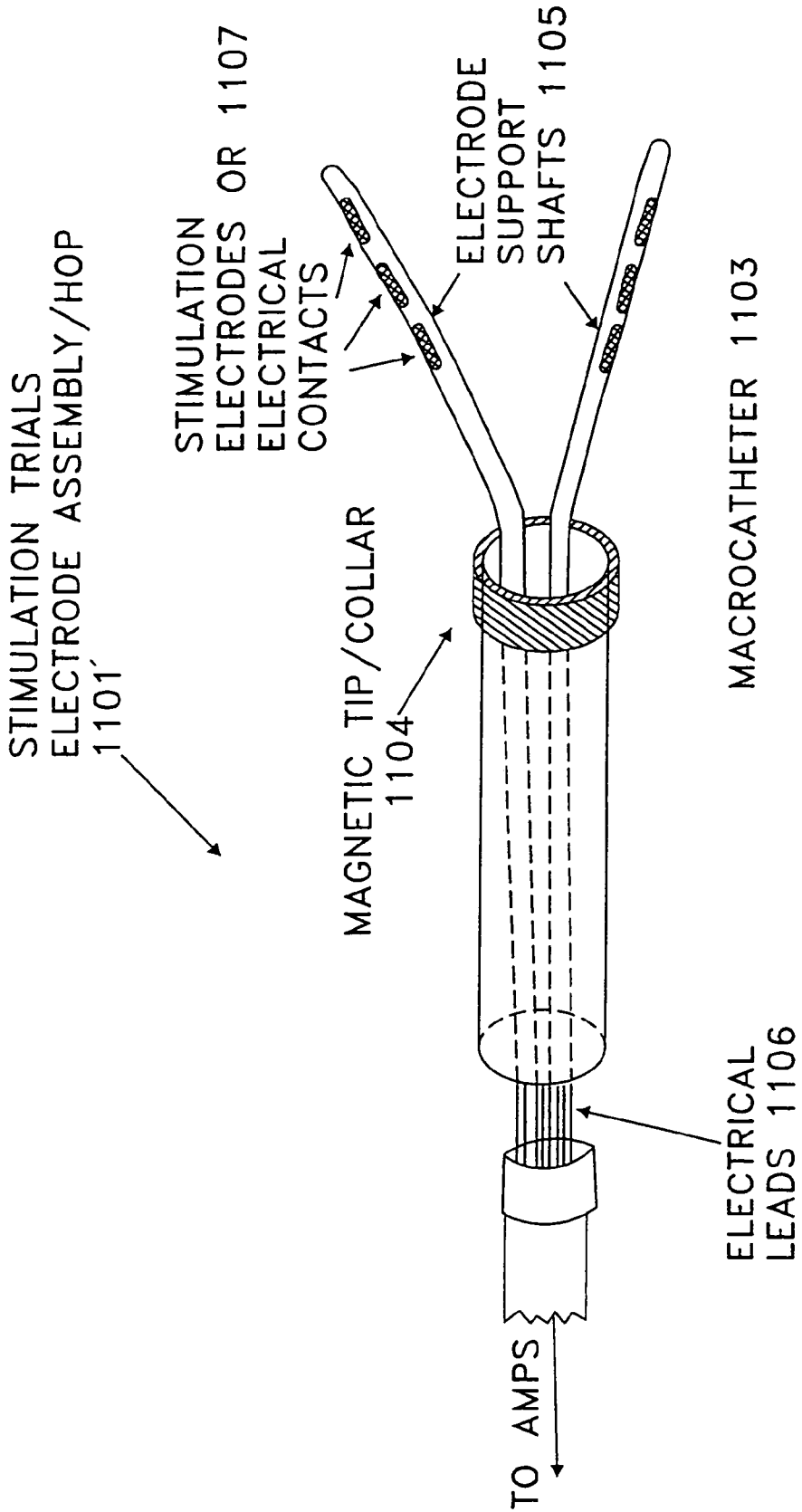

FIG. 27B

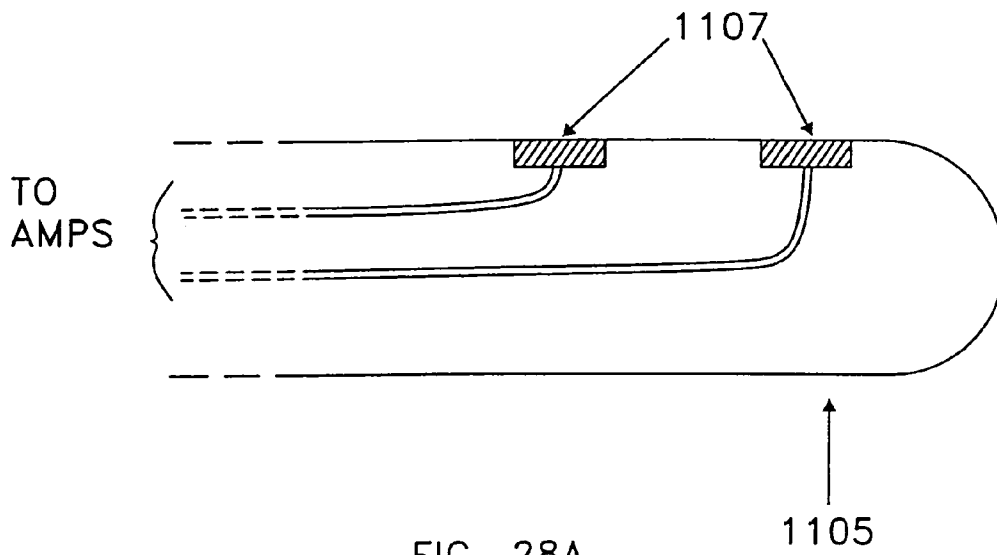

FIG. 28A

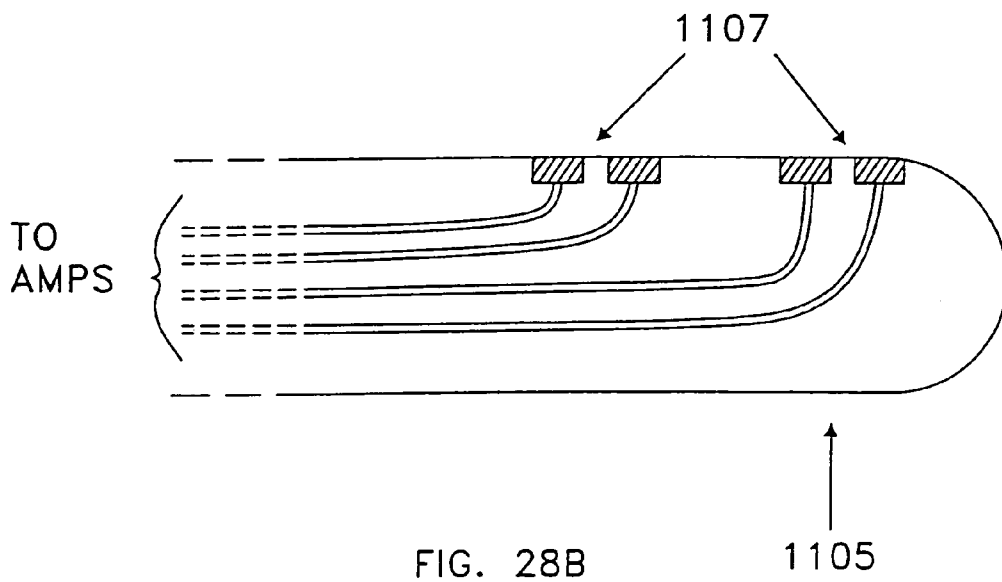

FIG. 28B

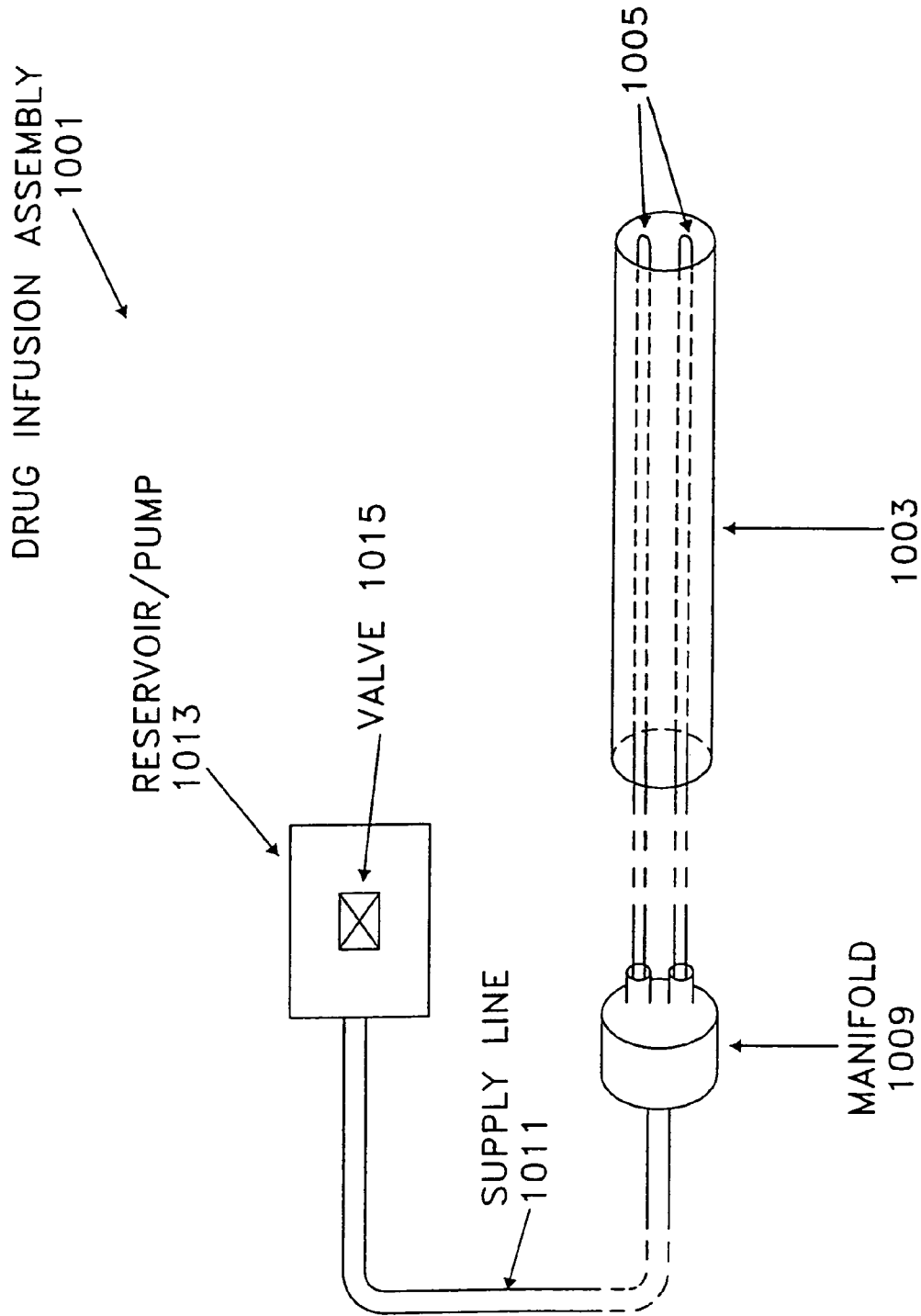

FIG. 29A

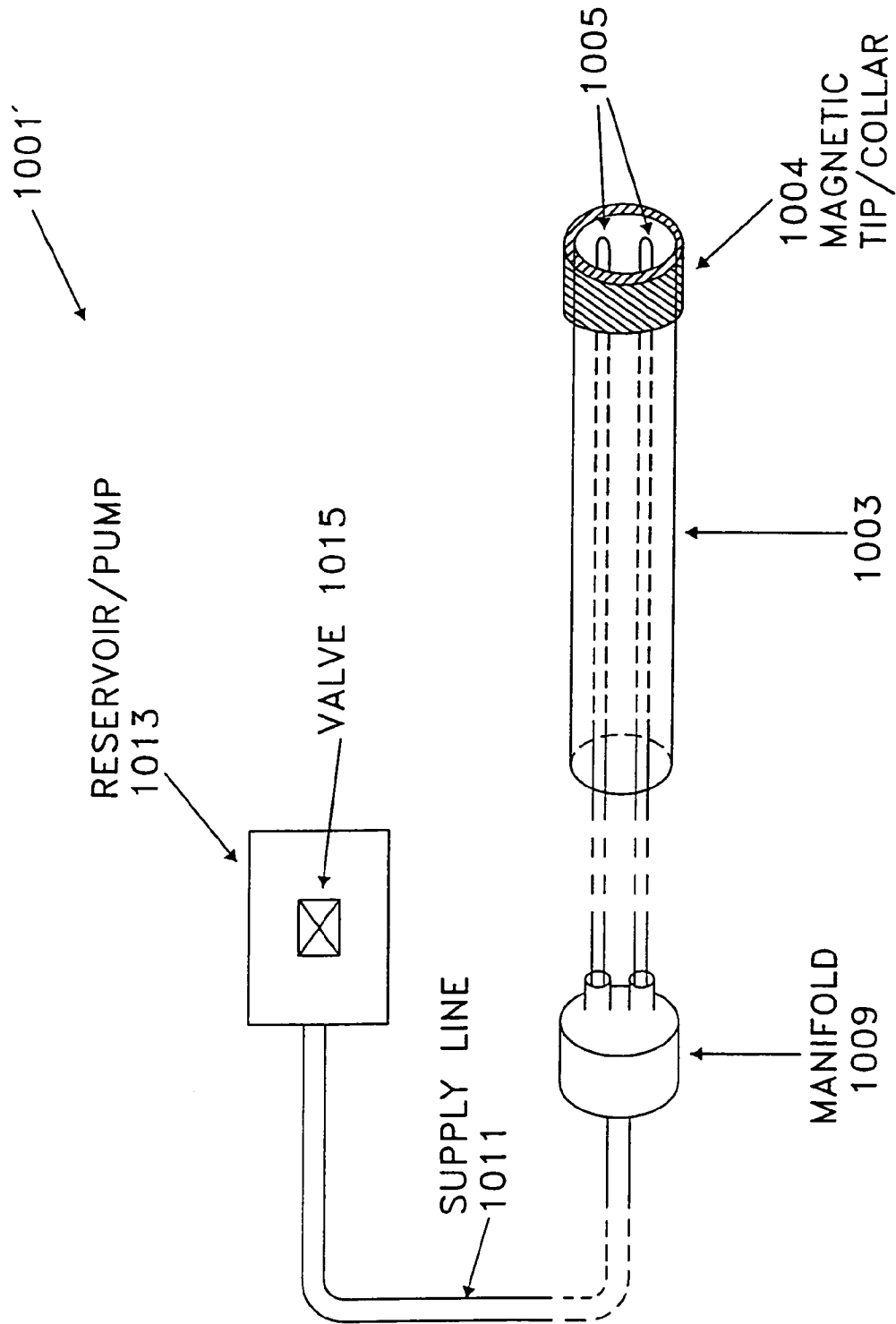

FIG. 29B

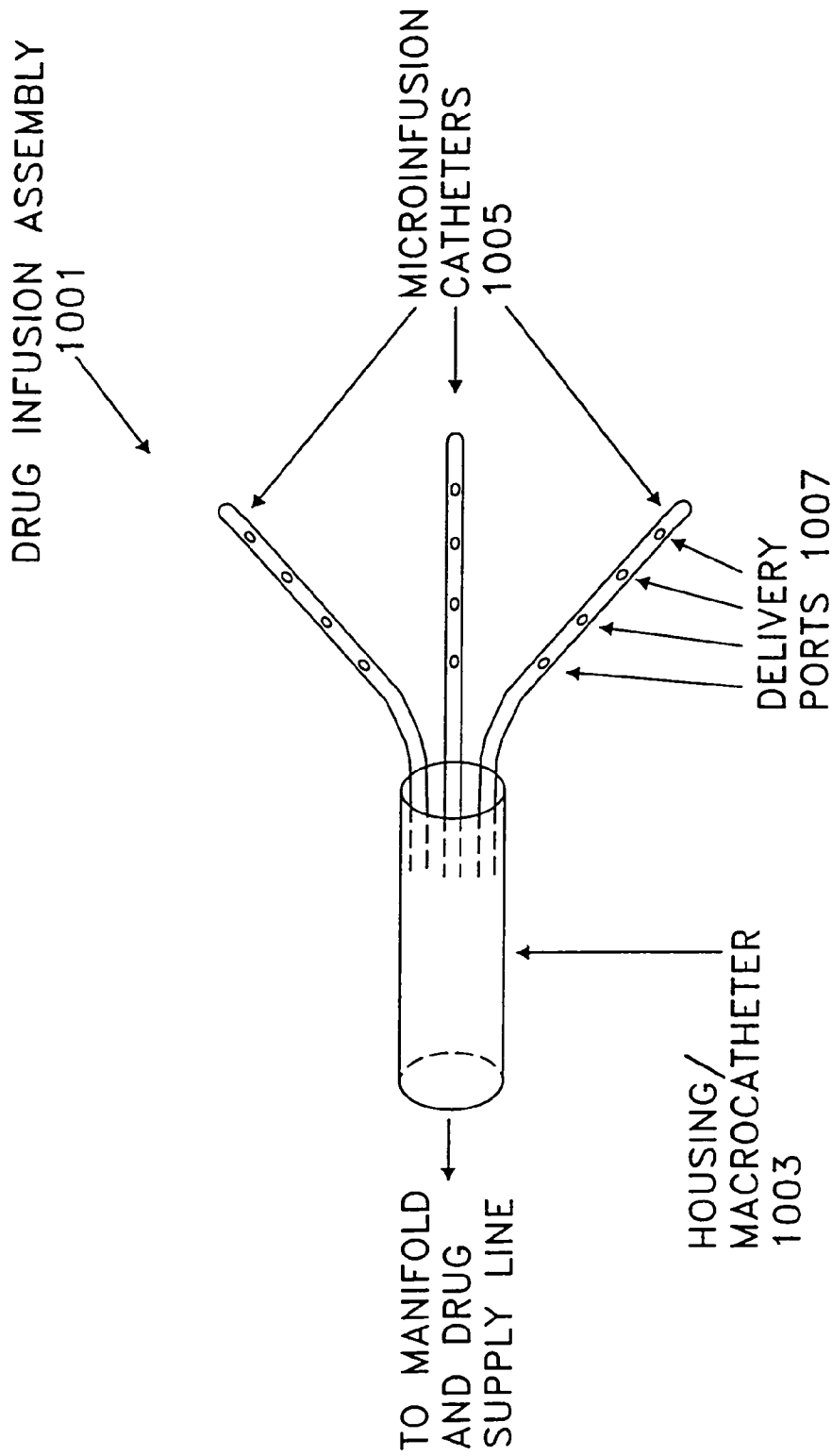

FIG. 30

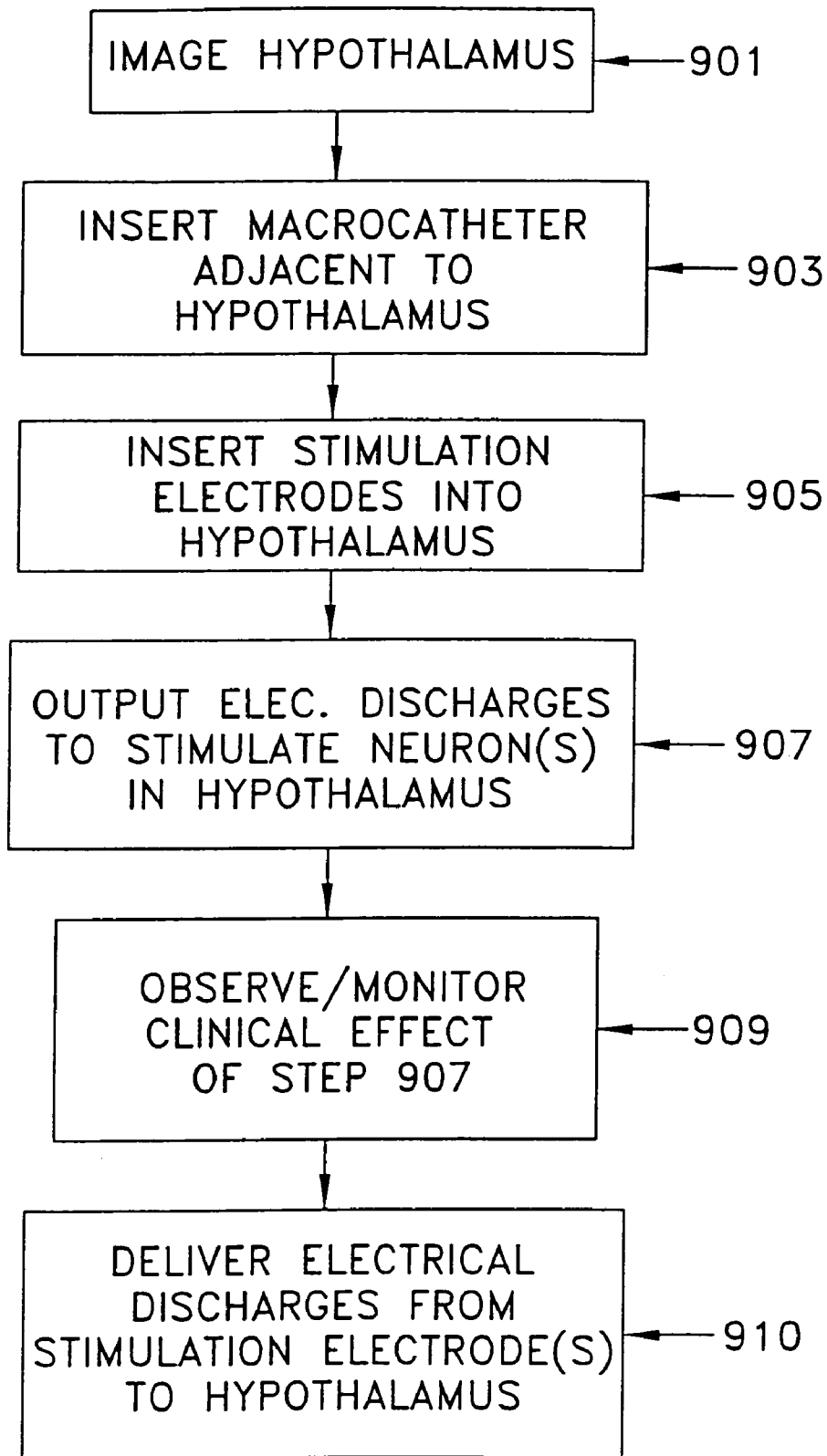

FIG. 31

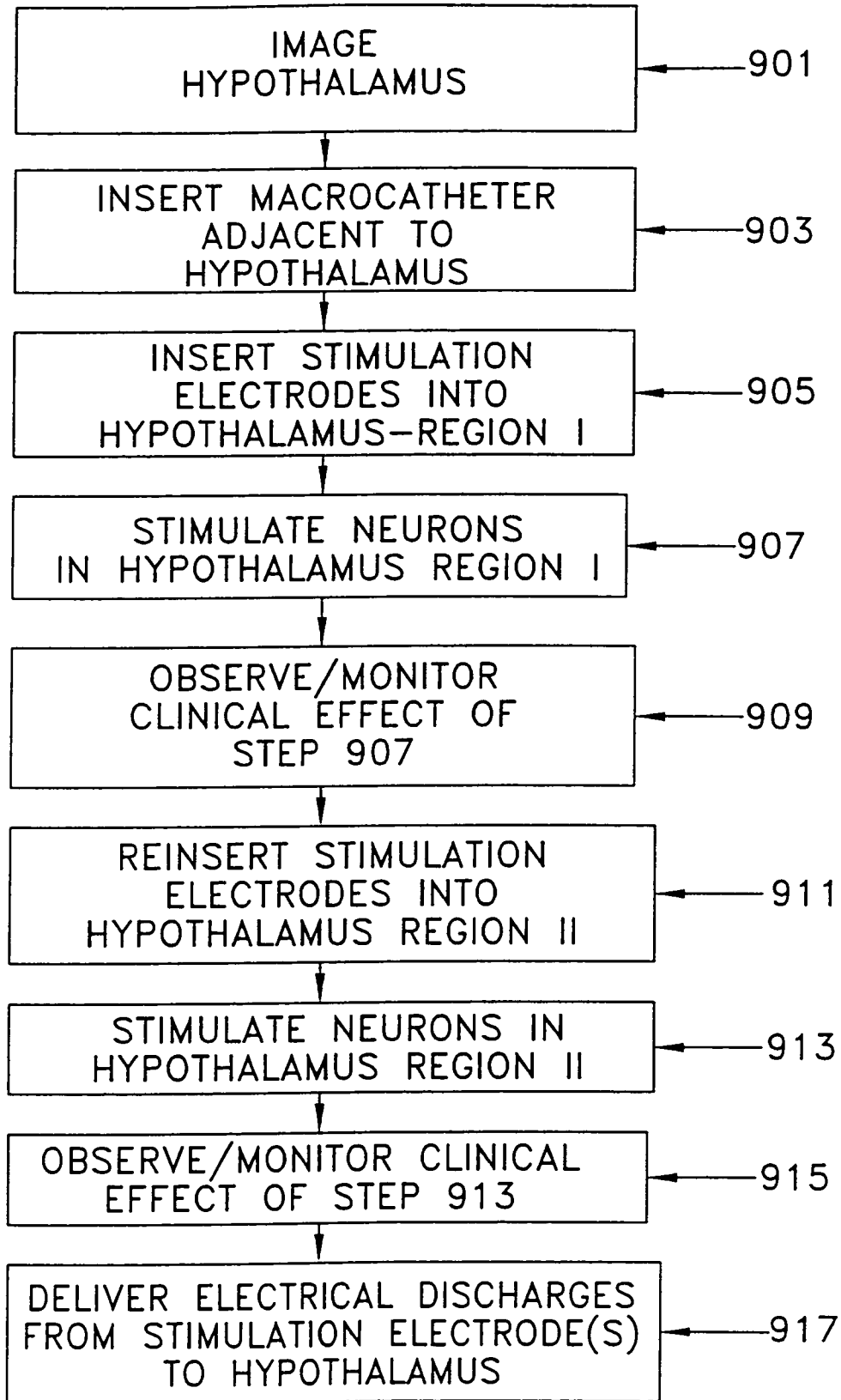

FIG. 32

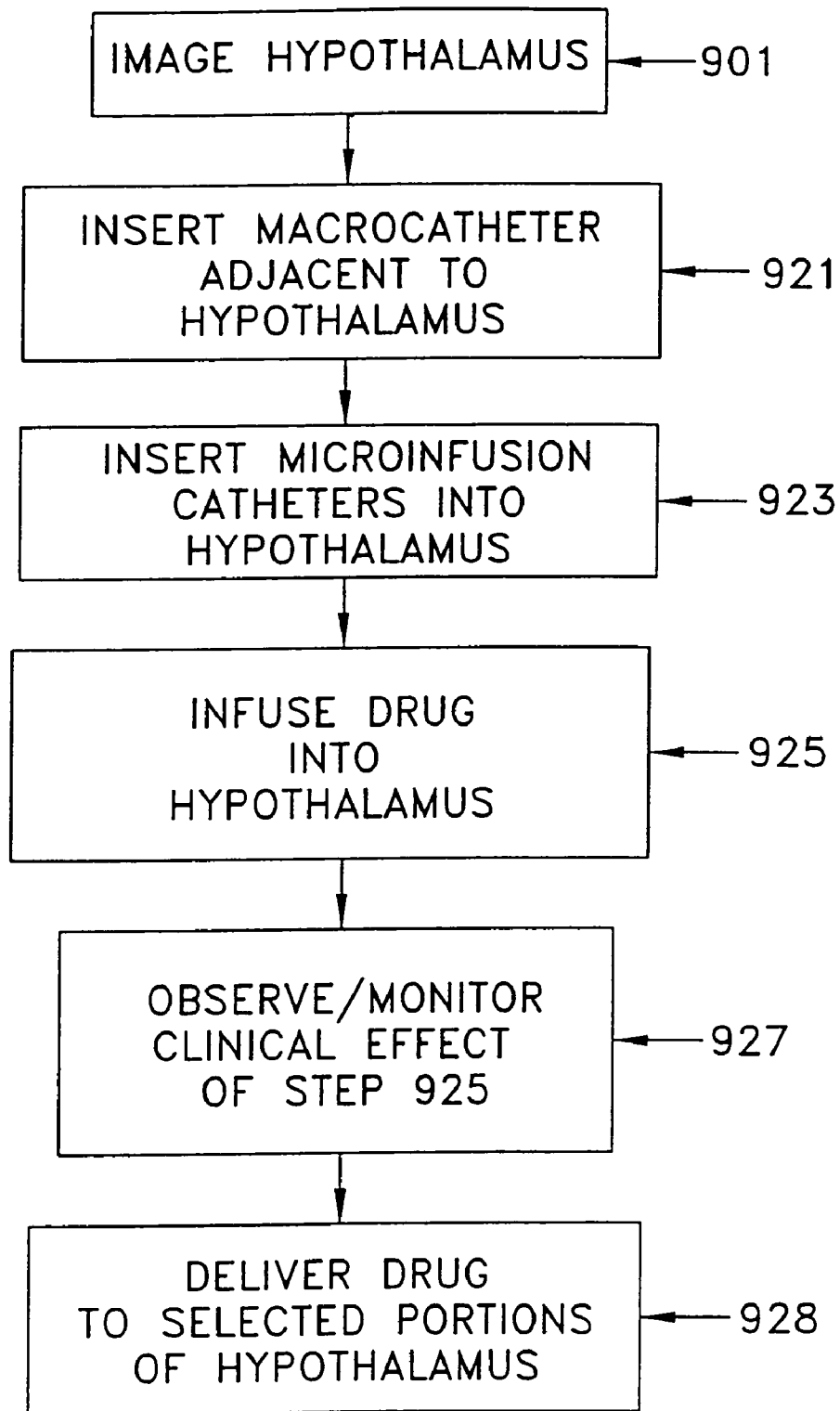

FIG. 33

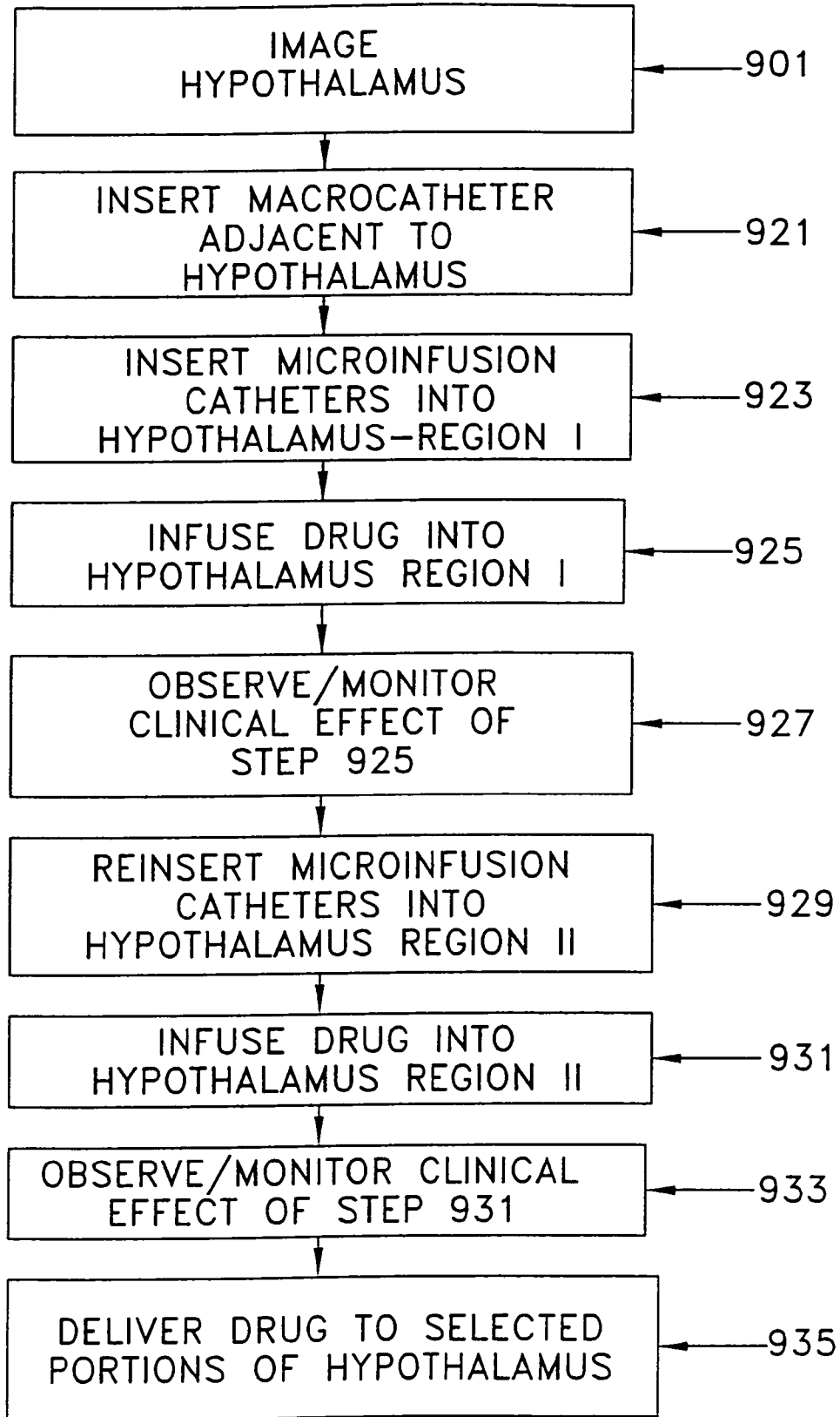

FIG. 34

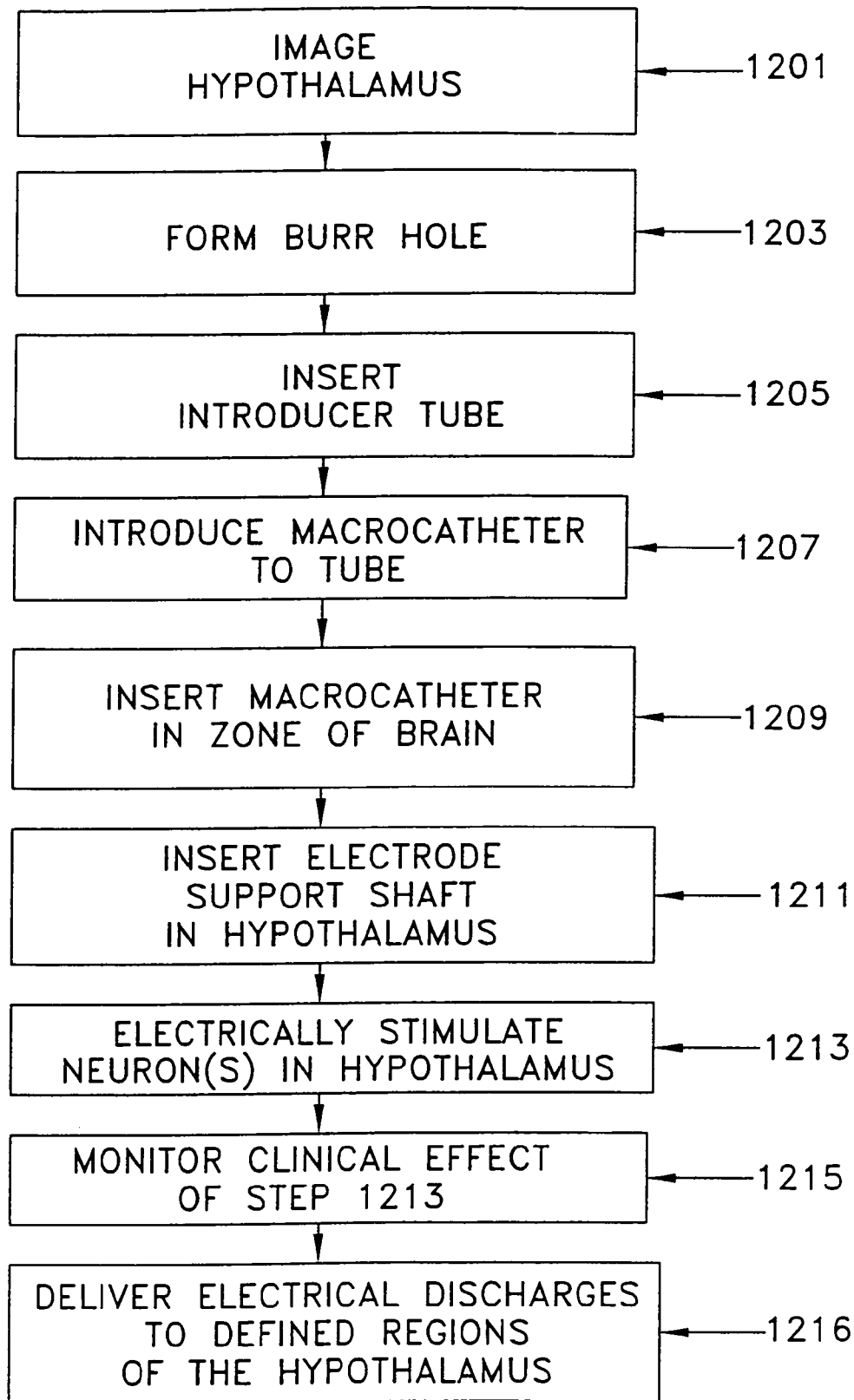

FIG. 35A

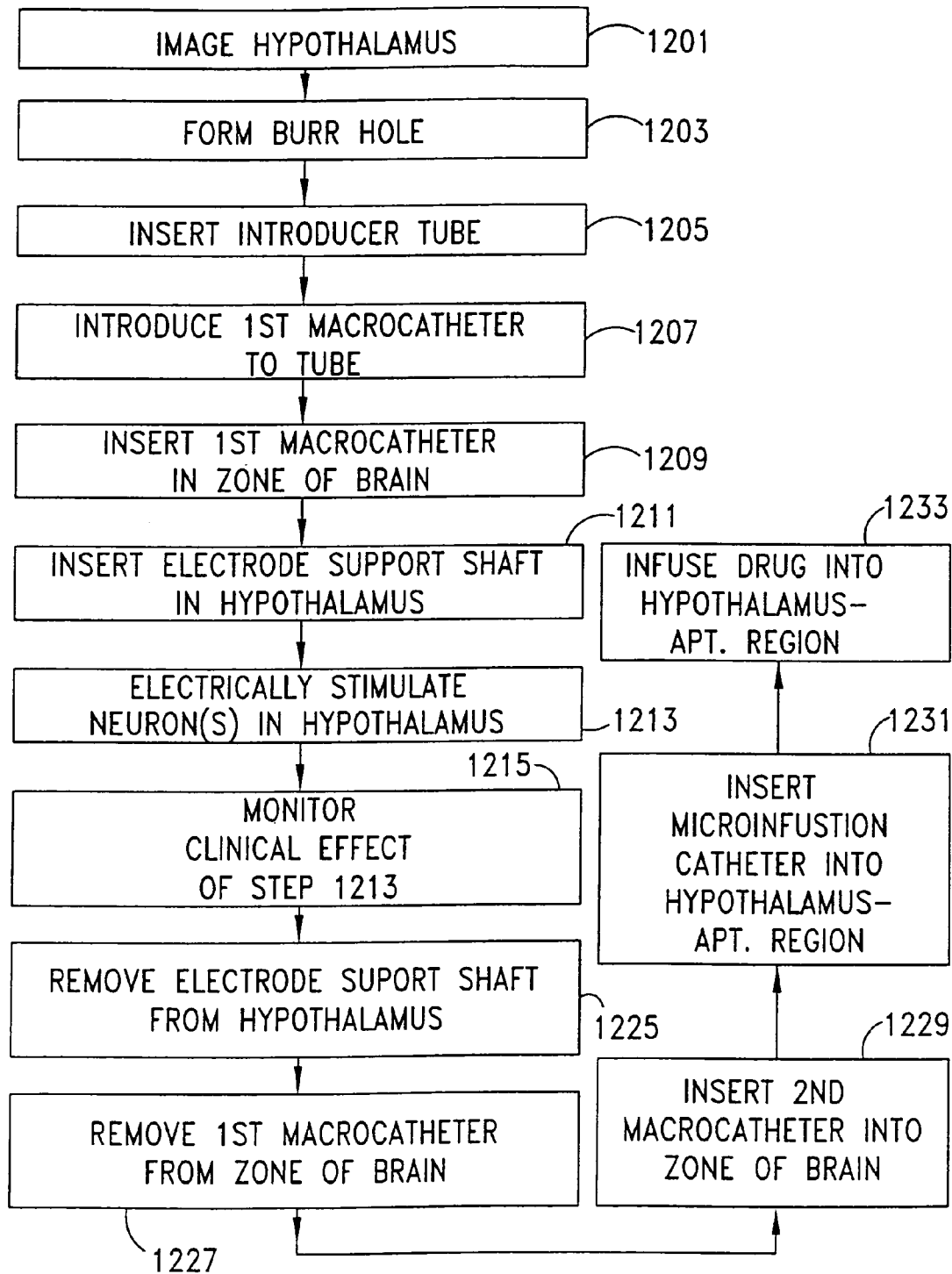

FIG. 35B

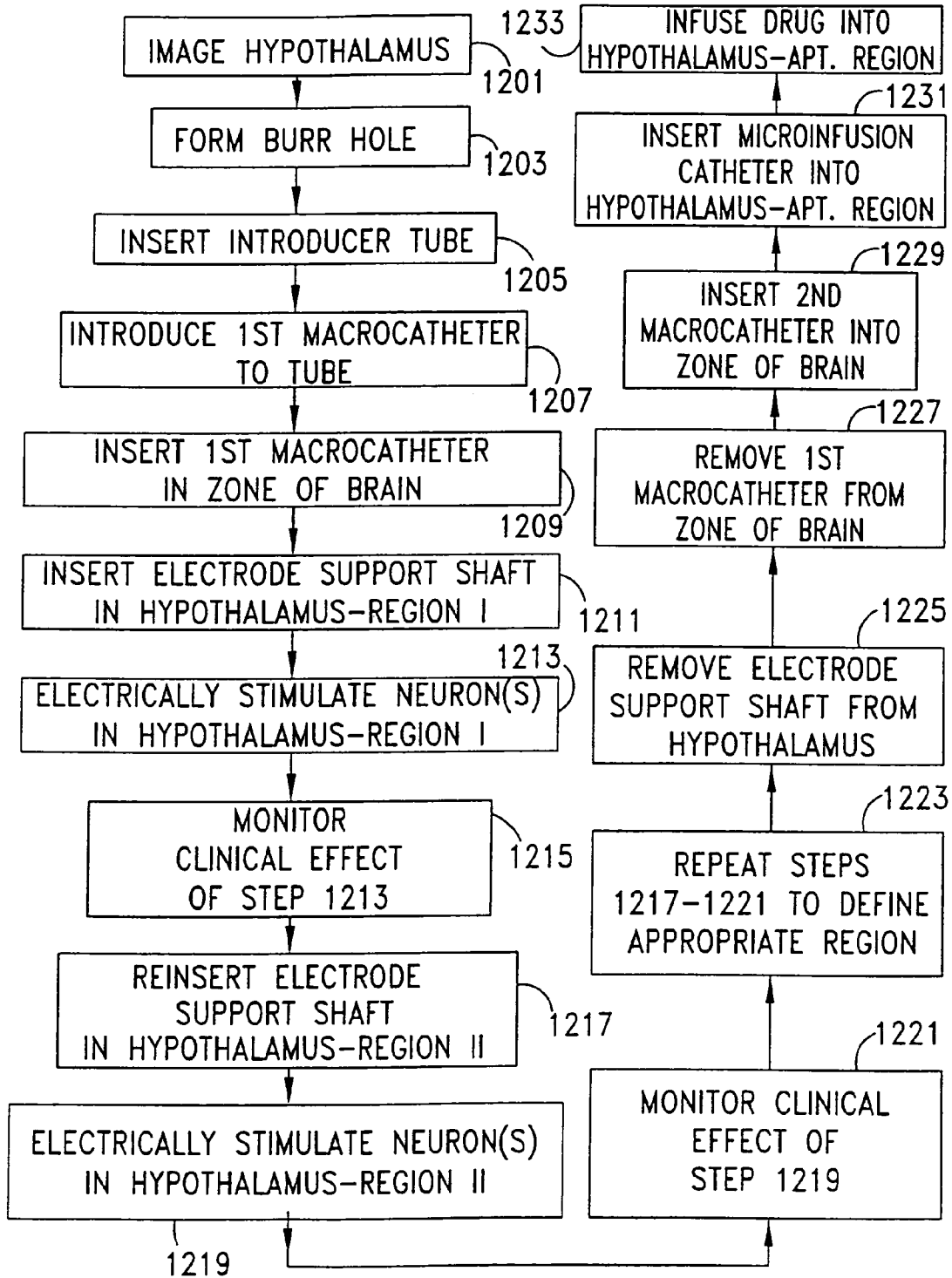

FIG. 35C

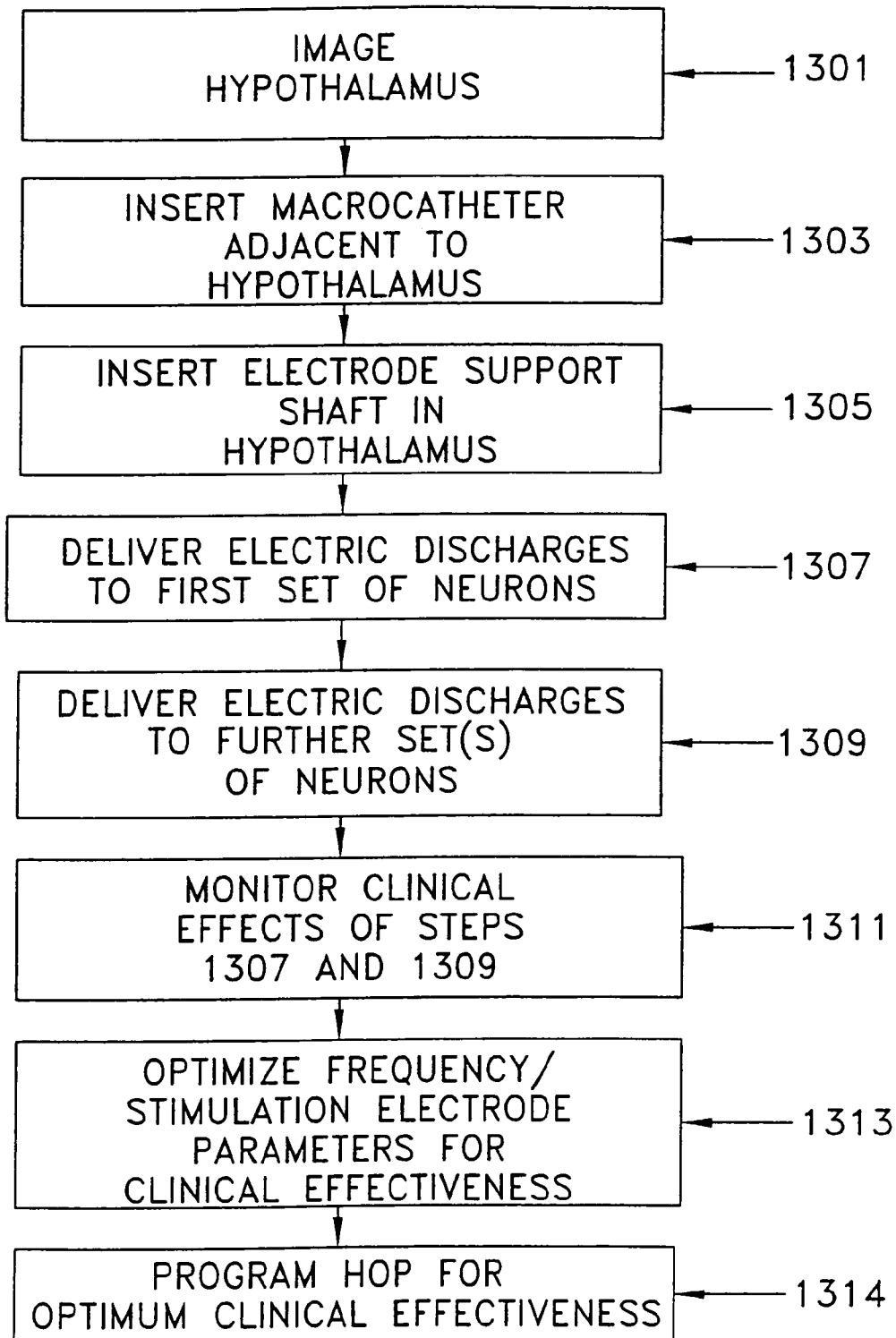

FIG. 36A

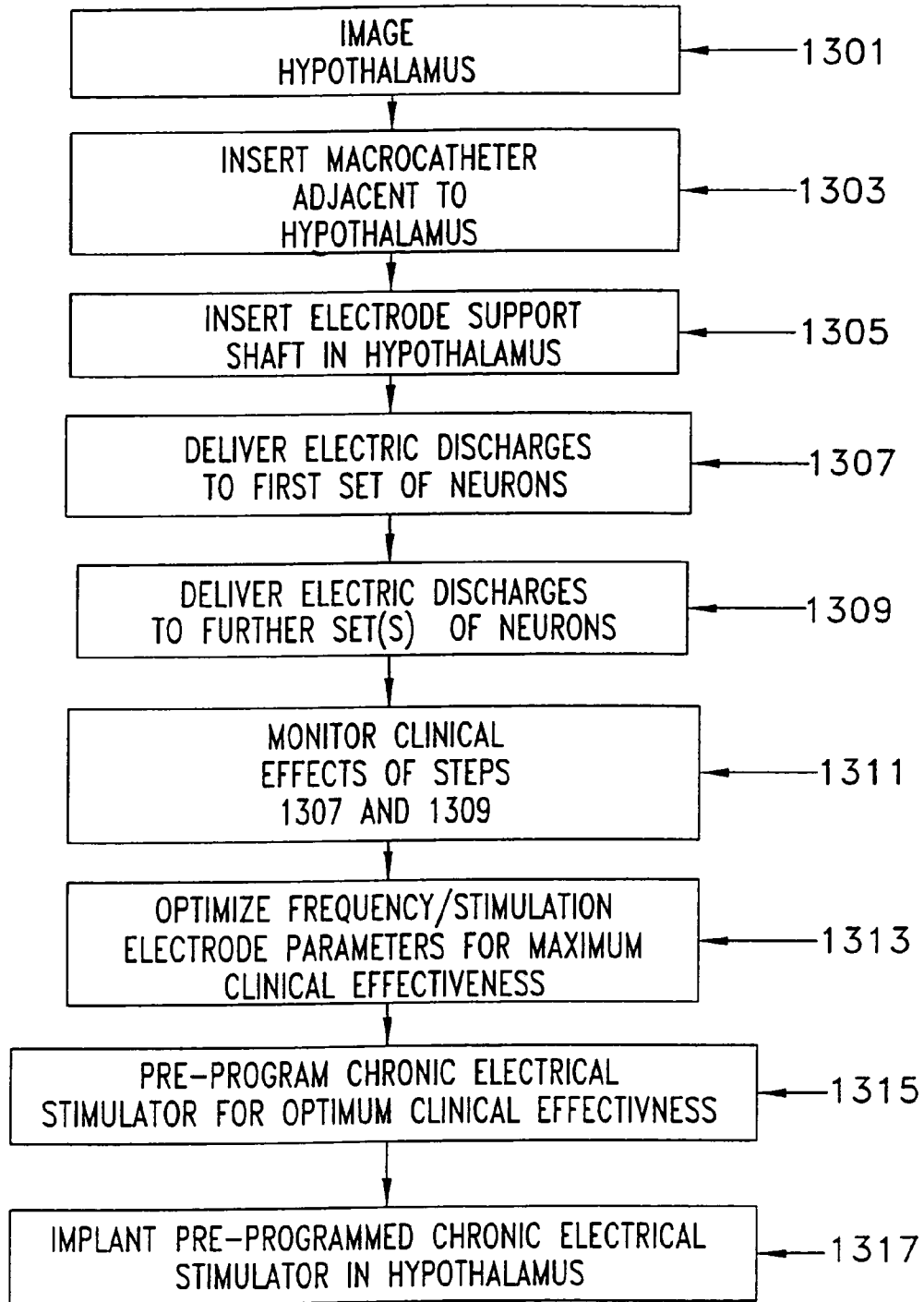

FIG. 36B

STEREOTACTIC HYPOTHALAMIC OBESITY PROBE

RELATED U.S. APPLICATION DATA

This Application is a Divisional of U.S. patent application Ser. No. 08/884,654 filed Jun. 27, 1997, now U.S. Pat. No. 6,129,685, which is a continuation-in-part of U.S. patent application Ser. No. 08/549,165 filed Oct. 27, 1995, U.S. Pat. No. 5,843,093, which is a continuation-in-part of U.S. patent application Ser. No. 08/332,755 filed Nov. 1, 1994 U.S. Pat. No. 5,697,975, which is a continuation-in-part of U.S. patent application Ser. No. 08/194,017 filed Feb. 9, 1994, now U.S. Pat. No. 5,496,369, the contents of each of which are incorporated herein by reference.

BACKGROUND OF THE INVENTION

1. Field of the Invention

This invention relates generally to an apparatus and method for delivering and detecting electrical signals to/from the patient's brain. In one embodiment, this invention also relates to an apparatus and method for performing ablative surgery on a patient. In particular the invention is concerned with an apparatus and method for performing brain surgery; and more particularly the invention is concerned with an apparatus and method for performing brain surgery by monitoring and selectively inactivating specific regions within the brain. The invention is also concerned with an apparatus and method for delivering therapeutic drugs, and more particularly is concerned with an apparatus and method for delivering therapeutic drug to a specific region within a patient's brain tissues, by monitoring and selectively delivering a drug to the target tissue. In one embodiment, this invention also relates to an apparatus and method for selective electrical stimulation of a patient's hypothalamus for the purpose of appetite regulation. In yet another embodiment, this invention relates to an apparatus and method for localized drug treatment for the purpose of appetite regulation by drug microinfusion into certain regions of the hypothalamus.

2. Background of the Related Art

Prior to the nineteenth century, physicians and scientists believed the brain was an organ with functional properties distributed equally through its mass. Localization of specific functions within subregions of the brain was first demonstrated in the 1800's, and provided the fundamental conceptual framework for all of modern neuroscience and neurosurgery.

As it became clear that brain subregions served specific functions such as movement of the extremities, and touch sensation, it was also noted that direct electrical stimulation of the surface of these brain regions could cause partial reproduction of these functions. Morgan, J. P., "The first reported case of electrical stimulation of the human brain," *J. History of Medicine*, January 1982:51-63, 1982; Walker, A. E., "The development of the concept of cerebral localization in the nineteenth century," *Bull. Hist. Med.*, 31:99-121, 1957.

Brain Mapping Studies

The most extensive work on electrical stimulation "mapping" of the human brain surface was carried out over several decades by Dr. Wilder Penfield, a neurosurgeon and physiologist at the Montreal Neurological Institute, mostly during the early to mid-1900's. He made precise observations during cortical stimulation of hundreds of awake

patients undergoing brain surgery for intractable epilepsy. Among his many findings, he noted that stimulation of the visual and hearing areas of the brain reproducibly caused the patients to experience visual and auditory phenomena. Penfield, W. et al., "Somatic motor and sensory representation in the cerebral cortex of man as studied by electrical stimulation," *Brain* 60:389443, 1937; Penfield, W. et al., *Epilepsy and the Functional Anatomy of the Human Brain*, London: Churchill, 1954; Penfield, W. et al., "The brain's record of auditory and visual experience," *Brain*, 86:595-696, 1963. Following the results of early human brain mapping studies, electrical stimulation of sensory brain regions to restore lost function was a logical therapeutic extrapolation. Drs. Brindley and Lewin of the University of Cambridge were the first to reduce the concept to practice by implanting a patient with a visual cortex neural prosthetic device. Brindley, G. S. et al., "The sensations produced by electrical stimulation of the visual cortex," *J. Physiol.* 196:479493, 1968. Their device consisted of an array of thin, flat electrodes placed on the surface of the visual cortex. The electrodes were remotely controlled with radio signals. A similar system was later tested at the University of Utah by Dr. Dobbelle and colleagues. Dobbelle, W. H. et al., "Artificial vision for the blind: stimulation of the visual cortex offers hope for a functional prosthesis," *Science* 183:440444, 1974.

Findings from these early British and American studies were consistent. Patients reliably perceived flashes of light (phosphenes) during periods of electrical stimulation, and simple patterns of phosphenes could be generated by simultaneously activating multiple contacts. While these findings strongly suggested the eventual feasibility of a cortical visual prosthetic device, many important design problems were insurmountable at that time.

Among these were an inability to precisely stimulate very small volumes of brain, the requirement for high stimulation currents to induce phosphenes, and an inability to access the patient's full "visual space" with the large array of surface electrodes used. Additionally, there were no miniature video cameras and small, powerful computers at the time capable of converting visual images into complex electrical stimulation sequences at ultra high speed.

Penetrating Electrodes as Neural Prostheses

The University of Utah has discontinued visual cortex prostheses research. However, the concept has been pursued at NIH where significant additional advances have been made. Their most important discovery to date relates to the use of needle shaped penetrating depth electrodes instead of flat surface stimulating electrodes. Bak, M., et al., "Visual sensations produced by intracortical microstimulation of the human occipital cortex," *Med. Biol. Eng. Comput.*, 28:257-259, 1990. Penetrating electrodes represent a major design improvement. They are placed within the brain tissue itself so there is optimal surface contact with elements of the brain that are targeted for stimulation. As a result, patients perceive visual phosphenes with approximately a thousand-fold less stimulation current than that required when surface electrodes are used. This allows for safe, chronic stimulation of very small discrete volumes of brain.

Additionally, penetrating electrodes transform what was in the past a two dimensional implant-brain interface (flat disks on the surface of the brain) into a three dimensional interface (multiple needle-like electrodes in parallel extending from the surface into the brain substance), which vastly increases the device's access to stimulation targets below the surface. To use a television screen analogy, a two dimensional surface-electrode array may have the potential of

generating an image on the "screen" composed of approximately one hundred discreet dots ("pixels"), whereas a three-dimensional array would potentially generate an image with many thousands of dots. The huge potential increase in image resolution would be achieved using a small fraction of the stimulation currents used in the past.

Penetrating electrodes have the potential to markedly increase both image quality and the safety of the stimulation process. Human experimental studies continue at the NIH campus. Extramural NIH funding is also directed at supporting engineering research on penetrating electrodes optimally suited for neural prosthetics applications. The University of Michigan, for example, has made use of computer-chip manufacturing techniques to synthesize exquisitely small electrode arrays. The etched electrical contacts on these devices are so small that the distance separating adjacent contacts can be in the range of 50 micrometers, approximately the diameter of two nerve cell bodies. Drake, K. L. et al., "Performance of planar multisite microprobes in recording extracellular single-unit intracortical activity," *IEEE Trans. BME*, 35:719-732, 1988.

During the 1970's the neural prosthetics group at the University of Utah not only explored the feasibility of a visual cortex neural prosthetic device, but carried out experiments in auditory cortex stimulation as well. Led by Dr. Dobelle, they formed a mobile research group that traveled to surgical centers throughout the United States when suitable experimental subjects were identified. These were patients who required temporal lobe surgery for tumor removal or treatment of intractable epilepsy, and who agreed to participate in the experimental protocol. Dobelle, W. H. et al., "A prosthesis for the deaf based on cortical stimulation," *Ann. Otol.*, 82:445-463, 1973.

The primary auditory region of the human brain is buried deep within the Sylvian fissure. It is not visible from the brain surface and its exact location varies slightly from one person to the next. MRI and CT scanners were not invented at the time of Dr. Dobelle's experiments so the anatomy of the patients' auditory cortex could not be studied prior to surgery, and this region could only be visualized with difficulty in the operating room after the Sylvian fissure was surgically dissected. Once the buried auditory cortex was exposed, surface stimulating electrodes were placed by hand over the area thought to be auditory cortex and the brain was stimulated in a fashion similar to that used to generate visual phosphenes.

Reproducible sound sensations were generated in the experimental subjects. Though these preliminary findings were encouraging, a range of limitations precluded further work by this group. Among the more daunting problems the Utah group faced were recruiting suitable patients for the experimental study and obtaining good stimulation characteristics from the experimental surface electrodes. The minimal stimulation threshold for eliciting sound sensations was found to be 6 milliamperes, which is too high to be tolerated chronically and is thousands of times greater than currents found subsequently to be required to generate phosphenes in visual cortex using penetrating electrodes.

Recent advances in MRI and computer technology now allow detailed preoperative imaging of human auditory cortex.

Another major technical innovation developed since the time of Dr. Dobelle's early experiments is the cochlear implant. An important aspect of the cochlear implant technology, which is now highly refined, involves transducing sound into complex electrical stimulation sequences. This large body of technical knowledge developed over the last

twenty years will be directly applicable to the auditory cortex prosthetic device and aid immeasurably in its research and development.

Normal Hearing

Mechanisms of human hearing are reviewed briefly to provide a framework for discussion of auditory neural prosthetic devices. The auditory system is composed of many structural components that are connected extensively by bundles of nerve fibers. The system's overall function is to enable humans to extract usable information from sounds in the environment. By transducing acoustic signals into electrical signals that can then be processed in the brain, humans are able to discriminate amongst a wide range of sounds with great precision.

FIGS. 1A and 1B show a side and front view of areas involved in the hearing process. In particular, the normal transduction of sound waves into electrical signals occurs in cochlea **110**, a part of the inner ear located within temporal bone (not shown). Cochlea **110** is tonotopically organized, meaning different parts of cochlea **110** respond optimally to different tones; one end of cochlea **110** responds best to high frequency tones, while the other end responds best to low frequency tones. Cochlea **110** converts the tones to electrical signals which are then received by cochlea nucleus **116**. This converted information is passed from cochlea **110** into brain stem **114** by way of electrical signals carried along the acoustic nerve and in particular, cranial nerve VIII (not shown).

The next important auditory structure encountered is cochlea nucleus **116** in the brain stem **114**. As the acoustic nerve leaves the temporal bone and enters skull cavity **122**, it penetrates brain stem **114** and relays coded signals to cochlear nucleus **116**, which is also tonotopically organized. Through many fiber-tract interconnections and relays (not shown), sound signals are analyzed at sites throughout brain stem **114** and thalamus **126**. The final signal analysis site is primary auditory cortex **150** situated in temporal lobe **156**.

The mechanisms of function of these various structures has also been extensively studied. The function of cochlea **110** is the most well-understood and the function of primary auditory cortex **150** is the least understood. For example, removal of the cochlea **110** results in complete deafness in ear **160**, whereas removal of primary auditory cortex **150** from one side produces minimal deficits. Despite extensive neural connections with other components of the auditory system, primary auditory cortex **150** does not appear to be necessary for many auditory functions.

Cochlear Implant

Cochlear implants were designed for patients who are deaf as a result of loss of the cochlea's sound transduction mechanism. Implant candidates must have an intact acoustic nerve capable of carrying electrical signals away from the middle ear into the brain stem. The device converts sound waves into electrical signals which are delivered through a multi-contact stimulating electrode. The stimulating electrode is surgically inserted by an otolaryngologist into the damaged cochlea. Activation of the contacts stimulates acoustic nerve terminals which would normally be activated by the cochlear sound transduction mechanism. The patient perceives sound as the coded electrical signal is carried from the middle ear into the brain by the acoustic nerve. Cohen, N. L. et al., "A prospective, randomized study of cochlear implants," *N. Engl. J. Med.*, 328:233-7, 1993.

In patients with hearing loss caused by dysfunction at the level of the cochlea, cochlear implants can be remarkably effective in restoring hearing. For example, some previously

deaf patients are able to understand conversations over the telephone following insertion of a cochlear implant.

Cochlear implants are surgically placed in the middle ear which is situated in the temporal bone. In patients who are already deaf, there is very little chance of any additional injury being caused by placement of a cochlear implant; they are very safe devices. Because of the low health risk associated with placing cochlear implants, obtaining experimental subjects during the early development stage was not difficult. In this setting design improvements occurred rapidly.

Cochlear Nucleus Implant

Patients are not candidates for cochlear implants if their hearing loss results from damage in auditory regions other than the cochlea. Because the first auditory relay station "downstream" from the cochlea and auditory nerve is the brainstem cochlear nucleus, this structure is a logical candidate for consideration as an implantation site. This approach was first developed at the House Ear Institute. Eisenberg, L. S. et al., "Electrical stimulation of the auditory brainstem structure in deafened adults," *J. Rehab. Res.* 24:9-22, 1987; Hitselberger, W. E. et al., "Cochlear nucleus implant," *Otolaryngol. Head Neck Surg.*, 92:52-54, 1984. As is the case with cochlear implants, sound waves are translated into a complex electrical code F. The implant's stimulation terminals are placed up against the cochlear nucleus, and the patient perceives sounds when the system is activated.

Data on efficacy is limited because relatively few patients have been tested with this device. Early findings demonstrate, however, that some degree of useful hearing is restored using this device. Environmental sounds such as a knock at the door and a telephone ringing have been detected by patients with a cochlear nucleus implant, and this improved auditory function has increased patients' ability to live independently.

Although work in the visual cortex demonstrates that central nervous system penetrating electrodes are significantly more effective than surface electrodes, use of penetrating electrodes in the cochlear nucleus has been discontinued for safety reasons described below.

For several reasons, there is significantly more risk associated with cochlear nucleus implants than cochlear implants. The cochlear nucleus is situated in the brain stem; a very sensitive and vital structure. Neurosurgical procedures in the brain stem are among the most difficult and dangerous operations performed. Infiltrating tumors within the substance of the brainstem, for example, are usually considered surgically inoperable. Surgical manipulation or injury of brainstem elements can cause devastating complications, including loss of normal swallowing functions, loss of control of eye movements, paralysis, coma, and death.

Because of their internationally renowned acoustic neuroma practice, doctors at the House Ear Institute are among the most experienced surgeons in the world at gaining surgical access to the brainstem surface. Acoustic neuromas are tumors arising from the supporting cells of the acoustic nerve. As they enlarge, these tumors expand into the cranial cavity and press up against the brainstem. Patients typically present with hearing loss, and a number of surgical approaches have been developed by otolaryngologists and neurosurgeons to remove these lesions.

Surgeons at the House Ear Institute have played a pioneering role in acoustic neuroma surgery and now routinely perform operations where the tumor is safely removed and the brainstem surface is visualized. They have placed

cochlear nucleus implants in deaf patients who have lost function of both acoustic nerves and are undergoing removal of an acoustic neuroma. This affords access to the brainstem surface during a medically necessary procedure.

The first cochlear nucleus implant used penetrating electrodes. These functioned well initially, however within two months they had migrated further into the brainstem, causing tingling sensation in the patient's hip as adjacent fiber tracts were inadvertently stimulated. This system was removed and surface electrodes have been used for cochlear nucleus implants since that time. Risks of implanting a cochlear nucleus device are such that patients are only candidates for implantation if they require surgery in that area of the brainstem for some other, usually life threatening reason.

It is difficult to find suitable patients for implantation and testing of cochlear nucleus implants. The most likely candidates are patients who have a rare form of neurofibromatosis and acoustic neuromas on both acoustic nerves. Martuza, R. L. et al., "Neurofibromatosis 2 (bilateral Acoustic Neurofibromatosis)," *N. Engl. J. Med.*, 318:684-688, 1988. A small number of these patients are referred regularly to such institutions as the House Ear Institute. Many university medical centers, however, would be unable to identify a single suitable candidate during a full year. In the fourteen years since its initial clinical application at the House Institute, cochlear nucleus implant use and testing has remained quite restricted (less than two implants per year average during the epoch reported in Eisenberg, L. S. et al., "Electrical stimulation of the auditory brainstem structure in deafened adults," *J. Rehab. Res.* 24:9-22, 1987.

Treating Deafness

Devices designed to treat deafness must take into consideration the underlying cause of deafness. For example, a patient with defective cochlea **110** who still has a functional acoustic nerve, may benefit from an artificial cochlea (cochlear implant). However, if the acoustic nerve is damaged and cannot carry electrical signals, then the problem is "too far downstream" in the signal processing sequence for a cochlear implant to be effective. In that situation, artificial signals must enter the auditory system "beyond the block" either in brain stem **114** or in auditory cortex **150**.

Parkinson's Disease

Parkinson's disease is a neuropathological condition of unknown aetiology which afflicts approximately 1 million individuals in the U.S. alone. Symptoms include a paucity of spontaneous movement (bradykinesia), rigidity, and tremor, which in many cases can be very disabling. The average age of onset is 57, with about 30% of cases being diagnosed before age 50. Since the 1960's a number of different drugs have been used for the treatment of Parkinson's disease. Drug treatment of Parkinson's disease may ameliorate some of the symptoms, but does not provide a cure for the disease. Furthermore, drugs used for the treatment of Parkinson's disease tend to become less effective in alleviating symptoms over time and often result in severe side effects. For example, L-dopa which has been widely used for the treatment of Parkinson's disease over the past 30 years, is associated with side effects which include uncontrollable muscular contraction of the limbs and face. And, with the passage of time many, perhaps all, patients fail to respond well to L-dopa treatment.

Prior Art Surgical Treatment of Parkinson's Disease

Surgical treatment by neurosurgeons to treat Parkinson's disease has its roots in the observation that some patients

exhibited decreased symptoms after experiencing a mild stroke. A widely accepted explanation for this observation is that the stroke caused destruction of fiber tracts or groups of neurons which had been conducting or generating abnormal signals. Early attempts to treat Parkinson's disease by selectively inactivating certain parts of the brain gave mixed results. The poor results obtained can be ascribed to a number of causes, particularly including poor targeting of brain tissue to be inactivated and imprecision in the design and use of the surgical probes.

Neurosurgeons at a number of medical centers worldwide are currently performing stereotactic thalamotomy or pallidotomy for the treatment of Parkinson's disease, in which regions within the target tissue (thalamus or globus pallidus) of the patient's brain are surgically accessed, physiologically monitored, and targeted for localized tissue destruction (L. Y. Laitinen, et al., "Leksell's Posteroventral Pallidotomy in the Treatment of Parkinson's Disease," *J. Neurosurg.*, 76, 53-61 (1992), R. P. Iacono, et al., "The Results, Indications, and Physiology of Posteroventral Pallidotomy for Patients with Parkinson's Disease," *Neurosurgery*, 36, 1118-1127 (1995), and references cited therein).

FIG. 12A shows the gross morphology, relative size and approximate location of the globus pallidus. The globus pallidus is a conical subcortical structure which is involved in the control of movement. FIG. 12B shows the gross morphology, relative size and approximate location of the thalamus. The thalamus is a relatively large ovoid body which, inter alia, relays sensory stimuli to the cerebral cortex.

Prior Art Stereotactic Pallidotomy

The currently used prior art procedure is quite complex and cumbersome. Briefly, it involves a preliminary step of obtaining microelectrode recordings from specific regions within the globus pallidus. Then, depending on the electrical potential(s) recorded from the particular region under study, the microelectrode is removed, and a macroelectrode is introduced into the same region of the globus pallidus to create a lesion thereat, thereby causing localized tissue destruction and irreversible inactivation of neurons in that region. This process must be repeated a number of times in order to obtain an appropriate "sample" of the globus pallidus.

According to the prior art stereotactic techniques, the trajectories of the introduced electrodes are perpendicular to the long axis of the globus pallidus, as shown in FIG. 12C. The prior art techniques therefore entail the surgeon making several passes through normal brain tissue. In addition, the electrode trajectories of the prior art techniques are the least useful with respect to sampling the target volume. Furthermore, the use of separate electrodes for monitoring neuron physiology (microelectrode) and for producing lesions (macroelectrode) is inefficient, time consuming, and is prone to error in positioning the macroelectrode.

Hypothalamic Obesity Probe

While malnutrition is known as a serious problem in many underdeveloped nations, obesity has been referred to as the major nutritional disorder of the developed world. This disorder is extremely prevalent: approximately one in three, or about 33%, of the population in the U.S. are overweight. Obesity is known to have serious adverse effects on health, and is associated with increased morbidity and mortality from a number of diseases and physiological conditions, including cardiovascular disease, stroke, coronary infarction, hypertension, diabetes, and hypercholesterolemia. {See, for example, Manson et al., *N. Engl. J. Med.*

333:677-685; 1995 OPTIONALLY OMIT CITATION.} In most cases a quantitative relationship exists showing a positive correlation between body weight of an individual of a given height and a particular health risk to that individual, i.e., the heavier the individual, the greater the risk. Apart from health-related factors discussed above, obesity is also undesirable in that it restricts mobility of the afflicted individual, and in addition can be a source of unacceptance, ridicule, and discrimination in certain societies.

Simply stated, weight gain in the otherwise healthy person is typically due to a net positive caloric balance, i.e., the total caloric content of food ingested exceeds the number of calories "burned" during metabolism over a defined period of time. It is not uncommon for an obese person to be as much as 30 Kg overweight. In order to lose 30 Kg of adipose tissue (fat), a negative net energy balance of about 210,000 Kcal (210,000 calories) is required. Naturally, it will require a period of several months to achieve weight loss on these proportions.

Current approaches to treating obesity include one or more of the following: adherence to a reduced calorie diet (with or without treatment with appetite suppressant drugs); lifestyle change, such as increased exercise regime; and surgery. The approach adopted for any one individual will depend on the degree of obesity, age of the individual, and other factors.

Morbid obesity is a prevalent, debilitating, and life threatening disorder for which surgical procedures may be indicated. Current surgical treatments involving the gastrointestinal tract seek to decrease the patient's ability to absorb calories from ingested caloric material (food and beverages). Such treatments comprise major surgical procedures which themselves carry considerable risk of mortality and mortality, and in addition such procedures often prove to be ineffective.

Apart from surgical procedures for the treatment of obesity, a number of attempts have been made to treat certain disturbances or disorders, including appetite disorders, by various forms of electrical stimulation of the head, CNS, or brain of a patient. For example, U.S. Pat. No. 5,540,734 discloses electrical stimulation of one or both of the trigeminal and glossopharyngeal nerves via one or more electrodes attached thereto. Such electrical stimulation is disclosed to serve as a means to treat, control or prevent various disorders (psychiatric, neurological, etc.), including eating disorders such as compulsive overeating. U.S. Pat. No. 5,443,710 discloses a method for treating various disorders, including appetite intrusiveness, by use of electroencephalographic disentrainment feedback to "exercise" the patient's brain, wherein the term "disentrainment" refers to the disruption of entrained brain wave patterns. U.S. Pat. No. 5,332,401 discloses an apparatus and method for transcranial electrotherapy (TCET), wherein the apparatus includes a skin electrode mounting system, e.g. for attachment to the earlobes of a patient. An electrical conductor for application to the skin comprises a generally conical needle point capable of penetrating the epidermis to provide good electrical contact over a small area. The disclosed apparatus and method can be used to treat a number of disorders including appetite disturbance; TCET administered at the appropriate time of day could be used to suppress (or enhance) appetite. U.S. Pat. No. 5,263,480 and U.S. Pat. No. 5,188,104 both to Wernicke disclose a method for treating patients having a compulsive eating disorder, such as compulsive eating to excess and compulsive refusal to eat (anorexia nervosa). The method includes the steps of detecting a preselected event indicative of an imminent need for treatment of the disorder,

and applying a predetermined stimulating signal to the patient's vagus nerve (tenth cranial nerve). U.S. Pat. No. 5,084,007 discloses a method for remediating imbalances or deficiencies in neuroactive substances that modulate neuro-humoral mechanisms. An object of the invention of the '007 is to provide a method for use in, e.g. stress-related disorders such as certain forms of obesity. The method involves the concomitant administration of transcranial electrostimulation (TE) and a neuroactive chemical promoter, to produce a greater effect than either treatment would produce acting individually. U.S. Pat. No. 4,646,744 discloses a method for treating various disorders or afflictions, e.g. stress, drug addictions, appetite disturbances, insomnia, etc., the method including the transcranial application of electrical signals to the patient. U.S. Pat. No. 3,762,396 discloses a method for treating various psychosomatic ailments by the application of synchronized energetic stimuli to the patient. In particular, electric current pulses are passed through the brain stem via electrodes attached to the back of the head and forehead. A second stimulus of electric current pulses is passed through the optic nerve via electrodes attached to the temples and forehead. The electrodes are mounted on a single elastic band which encircles the head of the patient, and provides electrode contact pressure.

Similarly, a number of attempts have been made to treat various disorders, including eating disorders, using certain drug therapies. For example, U.S. Pat. No. 5,554,643 discloses a series of synthetic peptide-related compounds which are pro-drugs useful, inter alia, as antipsychotic agents and for the treatment of obesity. The '643 patent refers to drug (amphetamine) delivery (to Sprague Dawley rats) via intracerebral injection cannulae as part of an experiment to demonstrate the usefulness of the disclosed peptide-related compounds as antipsychotic agents, while the disclosed novel compounds themselves are administered via intraperitoneal injection. The '643 also discloses appetite suppressant studies in which the novel compounds are administered intravenously through a cannulated jugular vein. In tests of anxiolytic activity exhibited by the disclosed compounds, pro-drug administration (to mice) is performed subcutaneously, intraperitoneally, or by mouth. U.S. Pat. No. 5,523,306 and U.S. Pat. No. 5,397,788 both also to Horwell et al. disclose substantially the same material as the '643. U.S. Pat. No. 5,399,565 discloses novel substituted pyrazolidinones which exhibit binding to cholecystokinin (CCK) receptors and gastrin receptors in the brain and/or peripheral sites. The pyrazolidinones are CCK and gastrin receptor antagonists which are useful for, inter alia, appetite regulation. The CCK and gastrin receptor antagonists may be administered orally, parenterally, transdermally, or as suppositories. U.S. Pat. No. 5,340,802 discloses peptide analog type-B cholecystokinin (CCK) receptor ligands which are useful for treating various disorders, including eating disorders related to appetite control. The compounds of the '802 may be administered in a number of ways, including orally, parenterally (injectable preparations), subcutaneously, topically, and via liposomes. U.S. Pat. No. 5,262,178 discloses a method and therapeutic composition for the treatment of pathological disorders associated with endogenous peptides by the administration of enkephalinase and novel forms thereof. Enkephalinase is implicated in the hydrolysis of endogenous enkephalins in brain tissue, while the effects of enkephalins include gastrointestinal function and increasing appetite. (Administration may be transdermal, intramuscular, intravenous, subcutaneous, intranasal, intraarticular injection, as a topical preparation for local therapy, by aerosol inhalation, by intravascular infusion, and by micro-

particulate delivery systems, e.g. liposomes.) U.S. Pat. No. 5,120,713 discloses a method for treating obese patients by administering to the patient both an alpha-2-adrenergic agonist, e.g. clonidine, and a growth hormone releasing peptide, e.g. growth hormone releasing hormone (GHRH), to restore or enhance growth hormone release in such patients. Typically clonidine is administered orally, preferably about 1 hour prior to administering the growth hormone releasing peptide, while GHRH is typically administered by injection (i.v. or s.c.).

In previous animal studies, direct microinjections of neuropeptide Y (NPY) into various discrete hypothalamic nuclei of the rat consistently increased food intake in all regions examined (Jolicoeur, F. B., et al., "Mapping of hypothalamic sites involved in the effects of NPY on body temperature and food intake," *Brain Research Bulletin*, 36:125-129, 1995).

Previous studies have demonstrated that an electrical stimulation device can be safely implanted into the human hypothalamus using standard stereotactic techniques. See for example Dieckman, G, et al., "Influence of stereotactic hypothalamy on alcohol and drug addiction", *Appl. Neurophysiol.*, 41:93-98, 1978; Mayanagi, Y., et al., "The posteromedial hypothalamus and pain, behavior, with special reference to endocrinological findings", *Appl. Neurophysiol.* 41:223-231, 1978; Nakao, H., "Emotional behavior produced by hypothalamic stimulation", *Am. J. Physiol.* 194:411418, 1958; Sano, K. "Effects of stimulation and destruction of the posterior hypothalamus in cases of behavior disorders and epilepsy", *Special topics in stereotaxis. Berlin Symposium 1970. Hippokrates Verlag Stuttgart.*

Similarly, prior art studies have demonstrated that manipulation of the human hypothalamus may effect changes in appetite. Thus Sano observed a marked increase in appetite, resulting in weight gain, as an unintended side effect of certain hypothalamic lesions (Sano, K. "Effects of stimulation and destruction of the posterior hypothalamus in cases of behavior disorders and epilepsy", *Special topics in stereotaxis. Berlin Symposium 1970. Hippokrates Verlag Stuttgart.*)

Animal studies directed at determining the effects of periodic hypothalamic electrical stimulation on weight gain in rats, have provided strong indirect evidence of the feasibility of using electrical stimulation of the hypothalamus therapeutically in obese humans to decrease body weight. For example, Bielejaw, et al., and Stenger, et al. found that periodic electrical stimulation of specific loci within the hypothalamus with a 50 Hz stimulation current reduces weight gain in rats. (Bielejaw, C., et al., "Factors that contribute to the reduced weight gain following chronic ventromedial hypothalamic stimulation", *Behavioral Brain Research* 62:143-148, 1994; Stenger, J., et al., "The effects of chronic ventromedial hypothalamic stimulation on weight gain in rats", *Physiol. Behav.* 50:1209-1213, 1991). In these animal studies, episodic periods of electrical stimulation were delivered to the rat hypothalamus from a single contact electrode coupled to an external stimulation source, as opposed to a chronic indwelling, multicontact electrode stimulation system contemplated by Applicant for human therapeutic use.

The above references are incorporated by reference herein where appropriate for appropriate teachings of additional or alternative details, features and/or technical background.

SUMMARY OF THE INVENTION

It is therefore an object of the instant invention to provide an apparatus including an introducer tube for introducing an electrode assembly into a specific region of a patient's brain.

It is a further object of the invention to provide an apparatus which includes an electrode assembly having a rigid electrode support shaft bearing at least one neuron-monitoring bipolar microelectrode.

It is a further object of the invention to provide an electrode assembly which includes at least one neuron-monitoring bipolar microelectrode, the electrical contacts of which are flexible.

It is a further object of the invention to provide an electrode assembly bearing at least one neuron-monitoring bipolar microelectrode, which can be used to obtain high quality recordings of action potentials of individual neurons chronically over a period of a number of days.

It is a further object of the instant invention to provide an apparatus which includes a dual purpose electrode assembly which is used for both monitoring neuronal physiology and for chronic electrical stimulation of a target cell or target tissue.

It is a further object of the instant invention to provide an apparatus which includes a dual purpose electrode assembly which is used for both monitoring neuronal physiology and for making lesions at the site of a target cell or target tissue.

It is a further object of the invention to provide a dual purpose multicontact neuron-monitoring and lesion-producing electrode assembly having a plurality of neuron-monitoring microelectrodes, and lesion-producing capability located at a plurality of sites on the electrode assembly, the sites of lesion-producing capability having a defined location relative to the location of the microelectrodes.

It is a further object of the invention to provide a dual purpose neuron-monitoring and lesion-producing electrode assembly having a plurality of neuron-monitoring microelectrodes and an equal number of adjacently located, spatially paired, or coincidental sites of lesion-producing capability.

It is still a further object of the invention to provide a dual purpose multicontact electrode assembly, with both neuron-monitoring and lesion-producing capability, having a magnetically tipped electrode support shaft for stereotactic placement of the electrode support shaft in a specific conformation within the target tissue, wherein the support shaft is positioned under remote control by means of an external magnetic field applied in the vicinity of the target tissue.

It is yet a further object of the invention to provide an apparatus for performing ablative surgery on a specific region of a patient's brain, including a magnetically tipped multicontact dual purpose electrode assembly having the capacity to both monitor individual neurons within the target brain tissue and to produce lesions at the site within the target tissue at which neurons were monitored.

It is a further object of the instant invention to provide an apparatus which includes a dual purpose electrode assembly which is used for both monitoring neuronal physiology and for delivering therapeutic drugs to the site of a target cell or target tissue.

It is a further object of the invention to provide a dual purpose multicontact neuron-monitoring/drug delivery electrode assembly having a plurality of neuron-monitoring microelectrodes and a plurality of sites capable of delivering a drug located on the electrode assembly, the sites of drug delivery capability having a defined location relative to the location of the microelectrodes.

It is a further object of the invention to provide a dual purpose neuron-monitoring/drug delivery electrode assembly having a plurality of neuron-monitoring microelectrodes and an equal number of adjacently located, spatially paired, or coincidental sites of drug delivery capability.

It is still a further object of the invention to provide a dual purpose multicontact electrode assembly, with both neuron-monitoring and drug delivery capability, having a magnetically tipped electrode support shaft for stereotactic placement of the electrode support shaft in a specific conformation within the target tissue, wherein the support shaft is positioned under remote control by means of an external magnetic field applied in the vicinity of the target tissue.

It is yet a further object of the invention to provide a method for delivering therapeutic drugs to target tissue(s) of a patient in which a dual purpose multicontact neuron-monitoring/drug delivering electrode assembly is inserted into the target tissue, at least one cell of the target tissue is monitored for physiologic activity using microelectrodes, and subsequently, a suitable dose of a therapeutic drug may be selectively delivered from a specific site on the electrode assembly to the specific region of the target tissue which was monitored.

It is a further object of the invention to provide a method for delivering therapeutic drugs to target tissue(s) of a patient, in which a dual purpose multicontact neuron-monitoring/drug delivering electrode assembly is inserted into the target tissue, the exact location and orientation of the target tissue being determined by computer assisted tomography (CT) scan and/or 3-dimensional magnetic resonance imaging (MRI).

It is yet a further object of the invention to provide a method for delivering therapeutic drugs to target tissue(s) of a patient, in which a dual purpose multicontact neuron-monitoring/drug delivery electrode assembly having a magnetic tip is moved to an appropriate position within the target tissue by the application of a magnetic field outside the patient's body part undergoing therapy.

It is still a further object of the invention to provide a dual purpose neuron-monitoring/drug delivery electrode assembly having at least one neuron-monitoring microelectrode, and at least one drug delivery port for the delivery of therapeutic drugs to specific, previously-monitored, sites within target tissue(s), the at least one drug delivery port having a defined location on the electrode assembly relative to the location of the microelectrodes.

It is yet a further object of the invention to provide a method for performing ablative surgery on a specific region of a patient's brain, in which a dual purpose multicontact electrode assembly is inserted into the target tissue, a plurality of neurons are monitored for physiologic activity using microelectrodes, and subsequently, without moving the microelectrodes, one or more macroelectrodes may be selectively activated or energized to form lesions within the target tissue at the site of the specific neurons which were monitored.

It is a further object of the invention to provide a method for performing ablative surgery on a specific region of a patient's brain, in which a dual purpose multicontact electrode assembly is inserted into the target tissue, the exact location and orientation of the target tissue being determined by computer assisted tomography (CT) scan and/or 3-dimensional magnetic resonance imaging (MRI).

It is yet a further object of the invention to provide a method for performing ablative surgery, in which a dual purpose multicontact electrode assembly having a magnetic

tip is moved to an appropriate position within the target tissue by the application of a magnetic field outside the patient's body part undergoing surgery.

Another object of the invention is to provide a prosthetic which can be placed in a cerebral cortex to reconstitute sensor input to the brain using microstimulation.

It is still a further object of the invention to provide a neural prosthesis including a multicontact electrode assembly which has a magnetic tip for stereotactic placement of the electrode assembly within auditory cortex.

It is still a further object of the invention to provide a multicontact electrode assembly which has a magnetic tip for stereotactic placement of the electrode assembly within the target tissue by means of applying an external magnetic field in the vicinity of the target tissue.

It is a further objective of the invention to provide a method for positioning a neural prosthesis having a magnetic tip in an appropriate conformation within the auditory cortex.

Another object of the invention is to provide a prosthetic which can be positioned in the brain such that an entire range of tonal frequencies processed by the human brain are accessed thereby.

Another object of the invention is to provide a prosthetic which allows a physician to physiologically test location and function of neural prosthetic electrodes in patients undergoing surgery for medically intractable epilepsy.

It is still yet a further object of the invention to provide a hypothalamic obesity probe for stereotactic placement in the hypothalamus of an obesity patient and for performing electrical stimulation trials to determine the effect of electrical stimulation of the hypothalamus on appetite regulation.

Another object of the invention is to provide a stimulation trials hypothalamic obesity probe, wherein the obesity probe is placed in the hypothalamus of an obesity patient, and the obesity probe is used to deliver electrical discharges to specific regions of the hypothalamus in order to determine which regions of the hypothalamus are involved in appetite regulation.

Another object of the invention is to provide a drug infusion assembly for microinfusing a drug into the hypothalamus of an obesity patient, the drug infusion assembly including at least one microinfusion catheter for placement in the hypothalamus of the patient, and a macrocatheter for housing the at least one microinfusion catheter, the macrocatheter having a magnetic unit to allow magnetic stereotactic manipulation of the catheter within the patient's brain.

Another object of the invention is to provide a method for defining an appropriate region within the hypothalamus in which to provide chronic electrical stimulation for the treatment of an obesity patient.

Another object of the invention is to provide a method for treating an obesity patient by outputting electrical discharges into a specific region, or specific regions, of the hypothalamus of the patient.

Another object of the invention is to provide a method for treating an obesity patient by infusion of a drug from a drug infusion assembly into specific regions of the hypothalamus of the patient.

Another object of the invention is to provide a method for treating an obesity patient by localized infusion of a drug from at least one drug delivery port of a microinfusion catheter into a specific region, or specific regions, of the hypothalamus of the patient.

One feature of the invention is that it includes a penetrating longitudinal support or electrode.

Another feature of the invention is that it can include a plurality of electrical contacts on the longitudinal support.

Another feature of the invention is that it includes a speech processor.

Another feature of the invention is that each electrode on the electrode support can separately and independently introduce electrical discharges in the brain.

Another feature of the invention is that it is arranged along the auditory cortex.

Another feature of the invention is that it can include a flexible multicontact electrode support.

Another feature of the invention is that the flexible multicontact electrode support is inserted into the brain using a rigid introducer.

Another feature of the invention is that a flat plastic plate attached to the longitudinal support helps position the prosthetic in the auditory cortex, the flat plastic plate having a cup to receive a sphere coupled to leads which interconnect the contacts to the speech processor.

Still another feature of the invention is that a plurality of electrode support shafts, each bearing a plurality of longitudinally arranged stimulation electrodes, can be stereotactically placed in the hypothalamus of a patient, and the clinical effects of electrical stimulation of neurons in the hypothalamus can be monitored.

Another feature of the invention is that a stimulation trials hypothalamic obesity probe includes a plurality of electrode support shafts, each bearing a plurality of longitudinally arranged stimulation electrodes, each of the plurality of stimulation electrodes capable of independently outputting electrical discharges over a variable frequency range from about 10 Hz to about 400 Hz.

Another feature of the invention is that a stimulation trials hypothalamic obesity probe can be stereotactically placed in a selected region of the hypothalamus of a patient, and the clinical effects of electrical stimulation of neurons by electrical discharges of various frequencies and from various stimulation electrodes of the hypothalamic obesity probe can be monitored in order to optimize the clinical effects of the electrical stimulation of neurons in the hypothalamus.

Another feature of the invention is that a drug infusion assembly can be positioned within the hypothalamus of a patient and a drug for the treatment of obesity can be microinfused from at least one microinfusion catheter into one or more specific sites within the hypothalamus.

Another feature of the invention is that an obesity patient can be treated for obesity using at least one microinfusion catheter to deliver a drug for obesity treatment to one or more specific sites within the hypothalamus.

Another feature of the invention is that an obesity patient can be treated for obesity by implanting a chronic electrical stimulator within a specific region, or specific regions, of the hypothalamus.

One advantage of the invention is that it includes contacts which enable a deaf patient to hear even though the patient's problem is not in his or her cochlear regions but instead is farther "down stream."

Another advantage of the invention is that it can utilize a single electrode or electrical contact mounted on an electrode support.

Another advantage of the invention is that it penetrates the brain, thus requiring a smaller, more readily tolerable current to stimulate localized regions of the auditory cortex, compared to the amount of current required during stimulation of the brain surface.

Another advantage of the invention is that the contacts are sufficiently closely arranged next to each other to provide high resolution stimulation of the auditory cortex.

Still another advantage of the invention is that a stimulation trials hypothalamic obesity probe can be stereotactically placed in one or more selected regions of the hypothalamus of a patient, and the clinical effects of electrical stimulation of the one or more selected regions of the hypothalamus can be monitored to determine which regions of the hypothalamus are involved in appetite regulation.

Another advantage of the invention is that a stimulation trials hypothalamic obesity probe can be stereotactically placed in one or more selected regions of the hypothalamus of a patient, and the clinical effects of electrical stimulation of the one or more selected regions of the hypothalamus can be monitored in order to define an appropriate region within the hypothalamus for placement of at least one microinfusion catheter.

Another advantage of the invention is that at least one microinfusion catheter can be placed within a selected region of the hypothalamus and a drug for the treatment of obesity can be microinfused into one or more specific sites within the hypothalamus.

These and other objects, advantages and features are accomplished by the provision of a neural prosthetic device for an auditory cortex of a patient, including: a speech processor for receiving and processing audio information and for outputting processed electrical signals; a support arranged in the auditory cortex having a plurality of electrical contacts independently outputting electrical discharges in accordance with the processed electrical signals; and electrical coupling means for electrically coupling the electrical contacts to the speech processor.

The above objects, advantages and features are further accomplished by the neural prosthetic apparatus as above, wherein the support is arranged in the auditory cortex and the plurality of electrical contacts are arranged such that the plurality of electrical contacts approximately tonotopically match the auditory cortex.

These and other objects, advantages and features are also accomplished by a method of implanting the above support, including the steps of: acquiring a 3-dimensional digital image of the patient's brain and storing the 3-dimensional digital image in a memory of a computer; digitally subtracting data from the 3-dimensional digital image to yield a modified 3-dimensional digital image which shows the orientation of the auditory cortex in the patient's brain; and inserting the support into the auditory cortex using the modified 3-dimensional digital image as a guide.

The above and other objects, advantages and features are further accomplished by the steps of: repeatedly outputting the processed electrical signals to the plurality of electrical contacts; and adjusting orientation of the support in the auditory cortex as the patient describes effects of the repeatedly outputting step.

These and other objects, advantages and features are accomplished by the provision of a stimulation trials hypothalamic obesity probe for stereotactic placement in the hypothalamus of a patient, the hypothalamic obesity probe including: at least one electrode support shaft, each of the at least one electrode support shafts having a plurality of electrical contacts, each of the plurality of electrical contacts electrically coupled to an electrical stimulation device for transmitting electrical signals to each of the plurality of electrical contacts, and each of the plurality of electrical contacts capable of independently outputting to electrical discharges to the hypothalamus; and a macrocatheter for

housing the at least one electrode support shaft, the macrocatheter including a magnetic unit for magnetic stereotactic placement of the macrocatheter to a location adjacent to the hypothalamus.

These and other objects, advantages and features are accomplished by the provision of a stimulation trials hypothalamic obesity probe for stereotactic placement in the hypothalamus of a patient, including: at least one electrode support shaft, each of the at least one electrode support shaft having a plurality of stimulation electrodes, each of the plurality of stimulation electrodes electrically coupled to an electrical stimulation device for transmitting electrical signals to each of the plurality of stimulation electrodes, and each of the plurality of stimulation electrodes capable of independently outputting electrical discharges to the hypothalamus; and a macrocatheter for housing the at least one electrode support shaft.

These and other objects, advantages and features are accomplished by the provision of a stimulation trials hypothalamic obesity probe which is placed in the hypothalamus of an obesity patient, and the obesity probe is used to determine an appropriate region of the hypothalamus in which to position a chronic electrical stimulation device, the chronic electrical stimulation device positioned in the hypothalamus for the suppression of appetite of the obesity patient.

These and other objects, advantages and features are accomplished by the provision of a drug infusion assembly for microinfusing a drug into the hypothalamus, the drug infusion assembly including: at least one microinfusion catheter, each of the at least one microinfusion catheters for placement in the hypothalamus, each of the at least one microinfusion catheters having a plurality of drug delivery ports, each of the plurality of drug delivery ports for delivering a drug to a separate site within the hypothalamus; a macrocatheter for housing the at least one microinfusion catheter; a drug delivery manifold, each of the at least one microinfusion catheters functionally coupled to the drug delivery manifold; a drug supply line functionally coupled to the drug delivery manifold; a drug reservoir/pump for retaining and pumping a drug, the drug reservoir/pump functionally coupled to the drug supply line; and the macrocatheter includes a magnet located at the distal end of the macrocatheter.

These and other objects, advantages and features are accomplished by the provision of a method for treating an obesity patient by outputting electrical discharges from a hypothalamic obesity probe to selected portions of the patient's hypothalamus, including the steps of a) obtaining a three dimensional digital image of the patient's brain, the image including and showing the position of the hypothalamus; b) inserting a macrocatheter adjacent to the hypothalamus; c) inserting at least one electrode support shaft into the hypothalamus, wherein the at least one electrode support shaft bears a plurality of longitudinally arranged stimulation electrodes, each of the plurality of stimulation electrodes being capable of independent control; d) outputting electrical discharges from at least one of the plurality of stimulation electrodes, thereby stimulating at least one neuron in the hypothalamus; e) monitoring the clinical effect or clinical effects of step d), in order to determine those particular stimulation electrodes of the plurality of stimulation electrodes which will provide a clinically useful effect; and f) delivering electrical discharges from those particular stimulation electrodes of the plurality of stimulation electrodes determined in step e) to provide a clinically useful effect.

These and other objects, advantages and features are accomplished by the provision of a method for treating an obesity patient by microinfusing a drug into one or more selected portions of the hypothalamus of a patient, including the steps of: a) obtaining an image of the hypothalamus of the patient; b) inserting a drug infusion assembly into the patient's brain adjacent to the hypothalamus, wherein the drug infusion assembly includes a macrocatheter, the macrocatheter housing at least one microinfusion catheter, and each of the at least one microinfusion catheters includes a plurality of independently controllable drug delivery ports; c) inserting the at least one microinfusion catheter into the hypothalamus; d) sequentially infusing a drug from various members of the plurality of drug delivery ports on the at least one microinfusion catheter into corresponding sites of the hypothalamus proximate the various members of the plurality of delivery ports; e) monitoring the clinical effect of step d), in order to determine which of the various members of the plurality of drug delivery ports will provide a useful clinical result; and f) delivering a drug from those selected members of the plurality of delivery ports determined in step e) to provide a useful clinical result.

These and other objects, advantages and features are accomplished by the provision of a method for treating an obesity patient by electrical stimulation of the hypothalamus of the patient, including the steps of: a) providing a three dimensional digital image of the patient's brain in order to indicate the precise location of the hypothalamus; b) forming a burr hole at an appropriate location in the patient's cranium; c) inserting an introducer tube into the burr hole; d) introducing a macrocatheter into the introducer tube, wherein the macrocatheter includes at least one electrode support shaft having a plurality of stimulation electrodes, the plurality of stimulation electrodes arranged longitudinally on the at least one electrode support shaft; e) inserting the macrocatheter in a zone of the patient's brain adjacent to the hypothalamus; f) inserting the at least one electrode support shaft into the hypothalamus; g) electrically stimulating at least one neuron in the hypothalamus by means of electrical discharges outputted from one or more of the plurality of stimulation electrodes; h) monitoring the clinical effect of step g) to define regions of the hypothalamus which will provide a desired clinical result when electrical discharges are outputted thereto; and i) outputting electrical discharges to regions of the hypothalamus defined in step h).

These and other objects, advantages and features are accomplished by the provision of a method for treating an obesity patient by chronic electrical stimulation of the hypothalamus of the patient, including the steps of: a) obtaining a three dimensional digital image of a patient's brain showing the location of the hypothalamus; b) inserting a macrocatheter into a zone of the patient's brain adjacent to the hypothalamus, wherein the macrocatheter houses at least one electrode support shaft, and each of the at least one electrode support shafts has a plurality of stimulation electrodes, and each of the plurality of stimulation electrodes is capable of independently outputting electrical discharges of various frequencies; c) inserting the at least one electrode support shaft into the hypothalamus of the patient; d) delivering electrical discharges of various frequencies from a first set of the plurality of stimulation electrodes to a first set of neurons within the hypothalamus; e) delivering electrical discharges of various frequencies from at least one further set of the plurality of stimulation electrodes to at least one further set of neurons within the hypothalamus; f) monitoring the clinical effects of steps d) and e) on appetite regulation by the patient, in order to determine the clinical

effects of various combinations of electrical discharge frequency/location of stimulation electrodes; g) optimizing the electrical discharges delivered to the neurons within the hypothalamus, according to steps d) and e), to provide optimum appetite regulation by the patient; and h) programming the hypothalamic obesity probe for chronic delivery of electrical discharges of defined frequency and at specific locations within the hypothalamus, as determined in step g), to provide optimum appetite regulation by the patient.

These and other objects, advantages and features are accomplished by the provision of a method for chronic electrical stimulation of the hypothalamus of an obesity patient, including the steps of: obtaining a three dimensional image of a patient's brain, the three dimensional image showing the location of the hypothalamus; inserting a macrocatheter into a zone of the patient's brain, wherein the zone is adjacent to the hypothalamus, wherein the macrocatheter houses at least one electrode support shaft, each of the at least one electrode support shafts having a plurality of stimulation electrodes, and each of the plurality of stimulation electrodes capable of independently outputting electrical discharges, the electrical discharges of low frequency or of high frequency; inserting the at least one electrode support shaft into a selected first region of the hypothalamus; stimulating, by means of electrical discharges outputted from the plurality of stimulation electrodes, neurons in the selected first region of the hypothalamus; and monitoring the clinical effects of the stimulating neurons step.

These and other objects, advantages and features are accomplished by the provision of a method for treating an obesity patient by placing a chronic electrical stimulator into the hypothalamus of the patient, including the steps of: a) obtaining a three dimensional image of a patient's brain, the three dimensional image showing the location of the hypothalamus; b) inserting a macrocatheter into a zone of the patient's brain, wherein the zone is adjacent to the hypothalamus, wherein the macrocatheter houses at least one electrode support shaft, each of the at least one electrode support shafts having a plurality of stimulation electrodes, and each of the plurality of stimulation electrodes capable of independently outputting electrical discharges, the electrical discharges of low frequency or of high frequency; c) inserting the at least one electrode support shaft into a selected first region of the hypothalamus; d) stimulating, by means of electrical discharges outputted from the plurality of stimulation electrodes, neurons in the selected first region of the hypothalamus; e) monitoring the clinical effects of step d); f) after step e), reinserting the at least one electrode support shaft into a selected additional region of the hypothalamus; g) stimulating, by means of electrical discharges outputted from the plurality of stimulation electrodes, neurons in the selected additional region of the hypothalamus; h) monitoring clinical effects of step g); i) repeating steps f) through h) until a satisfactory clinical effect is obtained; j) pre-programming the chronic electrical stimulator so as to duplicate the satisfactory clinical effect as obtained in step i); and implanting the preprogrammed chronic electrical stimulator in an appropriate region of the hypothalamus.

These and other objects, advantages and features are accomplished by the provision of a method for treating an obesity patient by infusion of a drug from a drug infusion assembly into the hypothalamus of the patient, the method including the steps of: a) obtaining a three dimensional image of a patient's brain, the three dimensional image showing the location of the hypothalamus; b) inserting a macrocatheter into a zone of the patient's brain, wherein the zone is adjacent to the hypothalamus, wherein the macro-

catheter houses at least one microinfusion catheter, each of the at least one microinfusion catheters having a plurality of drug delivery ports, and each of the plurality of drug delivery ports capable of independently outputting a drug, the drug capable of activating or deactivating neurons in one or more regions of the hypothalamus; c) inserting the at least one microinfusion catheter into a selected first region of the hypothalamus; d) infusing a quantity of a drug from at least one of the plurality of drug delivery ports to at least one neuron of the selected first region of the hypothalamus; and e) monitoring clinical effects of step d).

These and other objects, advantages and features are accomplished by the provision of a method for treating an obesity patient by chronic electrical stimulation of the hypothalamus of the patient, the method including the steps of: a) obtaining a three dimensional digital image of a patient's brain showing the location of the hypothalamus; b) inserting a macrocatheter into a zone of the patient's brain adjacent to the hypothalamus, the macrocatheter housing at least one electrode support shaft, each of the at least one electrode support shafts having a plurality of stimulation electrodes, and each of the plurality of stimulation electrodes capable of independently outputting electrical discharges of various frequencies; c) inserting the at least one electrode support shaft into the hypothalamus; d) delivering electrical discharges of various frequencies from a first set of the plurality of stimulation electrodes to a first set of neurons within the hypothalamus; e) delivering electrical discharges of various frequencies from at least one further set of the plurality of stimulation electrodes to at least one further set of neurons within the hypothalamus; f) monitoring the clinical effects of steps d) and e) on appetite regulation by the patient; g) based on steps d) through f), optimizing the electrical discharges delivered to the neurons within the hypothalamus for optimum appetite regulation by the patient; h) based on step g), pre-programming a chronic electrical stimulator for optimum clinical effectiveness in the patient; and i) implanting the pre-programmed chronic electrical stimulator in the hypothalamus of the patient.

One feature of the invention is that it can include a penetrating longitudinal support shaft bearing a single microelectrode for monitoring physiologic activity of a cell.

Another feature of the invention is that it can include a penetrating longitudinal support shaft bearing multiple microelectrodes for monitoring physiologic activity.

Another feature of the invention is that each microelectrode for monitoring physiologic activity can be bipolar.

Another feature of the invention is that each neuron-monitoring microelectrode of the electrode assembly can independently monitor the physiological activity of the neuron(s) with which it makes contact.

Another feature of the invention is that each lesion-producing macroelectrode of the electrode assembly can be independently energized to produce a localized lesion.

Another feature of the invention is that the electrode support shaft of the electrode assembly can be rigid.

Another feature of the invention is that the electrode support shaft of the electrode assembly can be flexible.

Another feature of the invention is that it can include a magnet at its distal end.

Another feature of the invention is that the flexible support shaft can be positioned generally along the long axis of the globus pallidus.

Another feature of the invention is that the multicontact electrode support shaft is introduced into the brain using a stereotactically inserted introducer tube.

One advantage of the invention is that it can function with a single electrode support shaft.

Another advantage of the invention is that it allows the neuron-monitoring and lesion-producing functions of prior art pallidotomy to be performed by the same electrode assembly.

Another advantage of the invention is that the microelectrode and macroelectrode contacts are sufficiently small and closely arranged on the electrode support shaft to enable high resolution monitoring and inactivation of the target tissue.

Another advantage of the invention is that it reduces the chances for error in placement of electrodes during surgical procedures by eliminating the need to use separate neuron-monitoring and lesion-making electrode assemblies.

Another advantage of the invention is that it allows the monitoring of a plurality of neurons and the subsequent production of a plurality of lesions following a single placement of the electrode support shaft within the target tissue.

Another advantage of the invention is that the neuron-monitoring microelectrodes and lesion-producing macroelectrodes are sufficiently small and closely arranged next to each other to enable a high degree of spatial correlation between neuron monitoring and neuron inactivation functions.

Another advantage of the invention is that the electrode support shaft can be retrieved from a given position within the brain to the introducer tube by exerting a force on a tether line.

Yet a further advantage of the invention is that the magnetically tipped electrode support shaft can be positioned in a desired spatial orientation within the brain by changing the magnitude and direction of magnetic forces which urge the electrode support shaft forwards.

These and other objects, advantages and features are accomplished by the provision of an apparatus for performing surgery on a patient, including: an electrode assembly including an electrode support shaft bearing a plurality of spatially paired or coincidental microelectrodes and macroelectrodes, and an introducer tube for introducing the electrode support shaft into the patient. The electrode assembly also includes a tether line for retrieving the electrode assembly from the target tissue.

These and other objects, advantages and features are accomplished by a method of performing surgery on a patient, including the steps of: introducing the distal end of the electrode support shaft into the target tissue, monitoring a plurality of neurons therein for their physiologic response, and subsequently selectively energizing one or more spatially paired or coincidental lesion-producing macroelectrodes according to the response recorded from the plurality of microelectrodes.

These and other objects, advantages and features are accomplished by a method of performing surgery on a patient, including the steps of: stereotactically inserting an introducer tube into the brain of a patient such that the distal end of the tube is positioned close to the target tissue, introducing an electrode assembly into the introducer tube, the electrode assembly including an electrode support shaft bearing a magnetic tip responsive to an external magnetic field, driving the magnetic tip of the electrode assembly through a defined trajectory within the globus pallidus, monitoring the physiological activity of at least one neuron within the globus pallidus, optionally, according to the

monitoring of the physiological activity, inactivating the at least one neuron by activating the at least one macroelectrodes.

These and other objects, advantages and features are accomplished by the provision of an apparatus for performing pallidotomy on a patient, including: an electrode assembly having a magnetically tipped, flexible electrode support shaft bearing a plurality of spatially paired microelectrodes and macroelectrodes, respectively for monitoring and inactivating specific neurons or groups of neurons, and an introducer tube for introducing the electrode support shaft into the patient. The electrode assembly also includes a tether line for retrieving the electrode assembly from the target tissue. The electrode assembly may then be repositioned in the home position within the introducer tube. These and other objects, advantages and features are accomplished by a method of performing a pallidotomy on a patient including the steps of: introducing the distal end of the electrode support shaft into the globus pallidus, monitoring a plurality of neurons therein for their physiologic response using a plurality of neuron-monitoring microelectrodes, and subsequently selectively energizing one or more spatially paired lesion-producing macroelectrodes according to the response recorded from the plurality of microelectrodes.

These and other objects, advantages and features are accomplished by a method of performing pallidotomy on a patient, including the steps of: stereotactically inserting an introducer tube into the brain of a patient such that the distal end of the tube is positioned close to the lateral globus pallidus; introducing an electrode assembly into the introducer tube, the electrode assembly including an electrode support shaft, the electrode support shaft having a magnetic distal end responsive to an external magnetic field and further bearing at least one neuron-monitoring microelectrode and at least one lesion-producing macroelectrode spatially paired with the at least one microelectrode; driving, by the application of an external magnetic field, the magnetic end of the electrode assembly through a defined trajectory within the globus pallidus; monitoring the physiological activity of at least one neuron with the at least one microelectrode; optionally, according to the monitoring of the physiological activity, inactivating the at least one neuron by applying lesion-forming energy to the at least one neuron via the at least one macroelectrode; and assessing the patient's response to the above steps.

These and other objects, advantages and features are accomplished by a method of making a dual purpose multicontact electrode assembly capable of monitoring and inactivating neurons, including the steps of: arranging a plurality of electrical contacts along the longitudinal axis of an electrode support shaft, and coupling each of the electrical contacts to at least one strand of electrically conductive material, whereby a suitable electric current may be conducted to or from each of the electrical contacts.

These and other objects, advantages and features are accomplished by a method of making a dual purpose multicontact electrode assembly, including the steps of: providing an electrode support shaft having a distal end and a proximal end, positioning a plurality of neuron-monitoring microelectrodes along the distal end of the electrode support shaft, and positioning each one of a plurality of lesion-producing macroelectrodes adjacent to each one of the plurality of microelectrodes, and affixing a magnet, responsive to an applied external magnetic field, to the distal end of the support shaft.

These and other objects, advantages and features are accomplished by a method of making an introducer tube,

including the steps of: providing a cylinder, rigidly attaching coaxially a conical neck to one end of the cylinder, the conical neck having a free end and the diameter of the conical neck having the same diameter as the cylinder at the point of juncture, the diameter of the conical neck increasing in the direction away from the cylinder, rigidly attaching coaxially a cylindrical end piece to the free end of the conical neck, the end piece having the same diameter as the free end of the conical neck, and providing sealing means for sealing the cylindrical end piece.

These and other objects, advantages and features are accomplished by provision of an introducer tube for introducing a device into the body of a patient, including: a cylindrical portion, a conical neck portion continuous with the cylindrical portion, a short cylindrical end piece continuous with the conical neck portion, and sealing means for sealing the proximal end of the introducer tube.

These and other objects, advantages and features are accomplished by provision of an apparatus for selectively inactivating neurons in a target tissue, including: an electrode support shaft, at least one lesion-producing macroelectrode arranged on the support shaft, and at least one neuron-monitoring microelectrode arranged on the support shaft, each one of the at least one microelectrodes having a defined location on the support shaft relative to the location of the at least one macroelectrode.

These and other objects, advantages and features are accomplished by provision of an apparatus including: a support shaft, at least one lesion-producing macroelectrode arranged along the support shaft for producing a lesion, and multiple neuron-monitoring microelectrodes arranged along the support shaft having a defined relative location on the shaft with respect to the at least one lesion-producing macroelectrode, the multiple neuron-monitoring microelectrodes monitoring neuronal activity and outputting signals which are used to determine whether to energize the at least one lesion-producing macroelectrode to produce the lesion.

These and other objects, advantages and features are accomplished by provision of an apparatus for making one or more lesions in a brain, including: an electrode support shaft, at least one lesion-producing macroelectrode disposed on the support shaft, and a fluid-coated introducer tube for introducing the support shaft into the brain, thereby allowing the lesion-producing macroelectrode to make the one or more lesions in the brain.

These and other objects, advantages and features are accomplished by provision of an apparatus, including: a flexible electrode assembly including an electrode support shaft, the support shaft having a magnetic tip which is responsive to an external magnetic field, one or more lesion-producing macroelectrodes arranged along the support shaft, an introducer tube for introducing the support shaft into a brain, and multiple neuron-monitoring microelectrodes arranged along the support shaft having a defined location on the support shaft relative to the one or more lesion-producing electrodes, the multiple neuron-monitoring microelectrodes monitoring neuronal activity and outputting signals which are used to determine whether to energize the one or more lesion-producing macroelectrodes.

These and other objects, advantages and features are accomplished by provision of an apparatus for producing one or more lesions at one or more locations in a globus pallidus of a human brain, including: a flexible electrode support shaft, a plurality of lesion-producing macroelectrodes arranged along the support shaft, and a plurality of neuron-monitoring microelectrodes arranged along the support shaft for outputting neuron activity signals, wherein the

23

support shaft is draped along the globus pallidus and selective ones of the lesion-producing contacts are energized, in accordance with the neuron activity signals, to produce the at least one lesion in the globus pallidus.

These and other objects, advantages and features are accomplished by provision of an apparatus for delivering one or more therapeutic drugs to target tissue of a brain, including: a support shaft, at least one drug delivery site capable of delivering a therapeutic drug arranged along the support shaft, and multiple neuron-monitoring microelectrodes arranged along the support shaft having a defined relative location on the shaft with respect to the at least one drug delivery site, the multiple neuron-monitoring microelectrodes monitoring neuronal activity and outputting signals which are used to determine whether to deliver a therapeutic drug from the at least one drug delivery site to the target tissue.

These and other objects, advantages and features are accomplished by a method of delivering one or more therapeutic drugs to specific locations within the brain of a patient, including the steps of: stereotactically inserting an introducer tube into the brain of a patient such that the distal end of the tube is positioned close to the target tissue; introducing an electrode assembly into the introducer tube, the electrode assembly including an electrode support shaft, the electrode support shaft bearing a magnetic tip responsive to an external magnetic field and further bearing at least one neuron-monitoring microelectrode and at least one drug delivery site capable of delivering a measured dose of a therapeutic drug, the at least one drug delivery site being spatially paired with the at least one microelectrode; moving, by the application of an external magnetic field, the magnetic tip of the electrode assembly to a defined location within the target tissue; monitoring the physiological activity of at least one neuron with the at least one microelectrode; and, optionally according to the monitoring of the physiological activity, delivering a measured dose of a therapeutic drug from the at least one drug delivery site.

These and other objects, advantages and features are accomplished by provision of a neural prosthetic device for a auditory cortex of a patient, the neural prosthetic device connected to a speech processor for receiving and processing audio information and for outputting processed electrical signals, and electrical coupling means for electrically coupling the plurality of electrical contacts to the speech processor.

These and other objects, advantages and features are accomplished by a method of implanting the support of the paragraph immediately above having a plurality of electrical contacts, including the steps of: acquiring a 3-dimensional digital image of the patient's brain and storing the 3-dimensional digital image in a memory of a computer, digitally subtracting data from the 3-dimensional digital image to yield a modified 3 dimensional digital image which shows the orientation of the auditory cortex in the patient's brain, inserting the support into the auditory cortex using the modified 3 dimensional digital image as a guide, repeatedly outputting processed electrical signals to the plurality of electrical contacts, and adjusting the orientation of the support in the auditory cortex, according to the patient's response to at least some of the processed electrical signals, the orientation of the support being controlled by adjustment of an applied external magnetic field.

These and other objects, advantages and features are accomplished by provision of an apparatus for selectively inactivating cells in a target tissue, including: an electrode support shaft, at least one cell-monitoring microelectrode

24

arranged on the support shaft, and at least one lesion-producing macroelectrode arranged on the support shaft, each one of the at least one macroelectrode having a defined location on the support shaft relative to the location of the at least one microelectrode.

These and other objects, advantages and features of the present invention will become more apparent from the following description of embodiments thereof, taken in conjunction with the accompanying drawings.

Additional advantages, objects, and features of the invention will be set forth in part in the description which follows and in part will become apparent to those having ordinary skill in the art upon examination of the following or may be learned from practice of the invention. The objects and advantages of the invention may be realized and attained as particularly pointed out in the appended claims.

BRIEF DESCRIPTION OF THE DRAWINGS

The invention will be described in detail with reference to the following drawings in which like reference numerals refer to like elements wherein:

FIGS. 1A and 1B show the orientation of a patient's auditory cortex in relation to the patient's cochlea and cochlear nucleus.

FIG. 2 shows a human cerebral cortex neural prosthetic.

FIG. 3A shows a side view of a plane A which intersects a coronal section with a Sylvian fissure exposed, and FIGS. 3B and 3C show the coronal section before and after tissue is digitally "peeled off" the Sylvian fissure.

FIG. 4 shows a neural prosthetic with a support having electrical contacts and its speech processor.

FIG. 5 shows a prosthetic which includes two longitudinal supports according to another embodiment of the invention.

FIG. 6 shows a prosthetic according to yet another embodiment of the invention.

FIG. 7A shows the prosthetic of FIG. 6 as looking down on the patient's brain surface, FIG. 7B shows a closer view of a stopping piece with a cup and a lid, and FIG. 7C corresponds to FIG. 7A with the support inserted.

FIG. 8 shows a magnetically tipped multicontact neural prosthesis.

FIGS. 9A, 9B and 9C illustrate three different embodiments of an electrode support shaft.

FIG. 10 shows an electrode support shaft bearing a plurality of bipolar neuron-monitoring microelectrode positioned adjacent to a plurality of neuron-inactivating sites.

FIGS. 11A and 11B show details of an embodiment of a dual purpose electrode assembly bearing bipolar microelectrodes, in which the pair of electrical contacts of the microelectrodes are closely juxtaposed, and are positioned coincidental with, and external to, the macroelectrodes.

FIG. 12A shows (arrows) the approximate location and orientation, gross morphology, and relative size of the globus pallidus.

FIG. 12B shows (arrow) the approximate location and relative size of the thalamus.

FIG. 12C shows the parallel linear trajectories of electrode assemblies, according to prior art pallidotomy.

FIGS. 13A-13C show apparatus for performing magnetic stereotactic surgery. FIG. 13A shows an introducer tube positioned within the patient's skull pointing generally in the direction of the globus pallidus. FIG. 13B shows the electrode assembly ex situ. FIG. 13C shows the electrode assembly within the introducer tube with the sealing cap unattached.

25

FIG. 14 shows a general view of the introducer tube in cross section.

FIG. 15 shows a more detailed view of the proximal end of the introducer tube with the electrode assembly positioned therein, and the sealing cap unattached.

FIG. 16 shows a more detailed view of the proximal end of the introducer tube with the sealing cap attached.

FIG. 17 shows the electrode support shaft positioned within the globus pallidus, together with a magnified view of a microelectrode and a macroelectrode.

FIG. 18 depicts the movement of the magnetically tipped electrode assembly in the direction away from the introducer tube towards the apex of the globus pallidus.

FIG. 19 shows steps in performing magnetic pallidotomy using a dual purpose multicontact electrode assembly.

FIG. 20 depicts the tether line of the electrode assembly being pulled upwards and the electrode assembly returning to the introducer tube from the globus pallidus.

FIG. 21 shows steps in making a dual purpose multicontact electrode assembly useful in performing magnetic stereotactic surgery.

FIG. 22 shows steps in making an introducer tube, according to the invention, for introducing an electrode assembly into a patient.

FIG. 23 shows an electrode support shaft of a dual purpose electrode assembly, capable of both monitoring individual neurons and delivering a chemical agent to a specific site within a patient's brain.

FIG. 24 shows steps in making a dual purpose multicontact electrode assembly capable of both monitoring physiological activity at the individual cell or tissue level, and delivering a chemical agent to a specific site within a patient's tissues.

FIG. 25 shows a dual purpose neuron-monitoring/drug delivery electrode assembly, bearing a plurality of multipolar neuron-monitoring electrodes and a plurality of drug delivery ports.

FIGS. 26A and 26B are cross-sectional views of a dual purpose neuron-monitoring/drug delivery electrode assembly at two different positions along its longitudinal axis showing four (26A) and three (26B) drug delivery supply lines, respectively, located within the electrode support shaft.

FIG. 27A shows a perspective view of a hypothalamic obesity probe for performing electrical stimulation trials of specific regions of the hypothalamus, according to one embodiment of the invention;

FIG. 27B shows a perspective view of a hypothalamic obesity probe including a macrocatheter having a magnetic tip, according to another embodiment of the invention;

FIGS. 28A and 28B show cross-sectional views of an electrode support shaft having monopolar electrodes, and of an electrode support shaft having bipolar electrodes, respectively, according to other embodiments of the invention;

FIG. 29A shows a perspective view of a hypothalamic drug infusion assembly, according to another embodiment of the invention;

FIG. 29B shows a perspective view of a hypothalamic drug infusion assembly, including a macrocatheter having a magnetic tip, according to another embodiment of the invention;

FIG. 30 shows a perspective view of the distal end of the macrocatheter of a hypothalamic drug infusion assembly, showing microinfusion catheters protruding therefrom, according to another embodiment of the invention;

26

FIG. 31 schematically summarizes steps involved in a method for positioning a chronic electrical stimulator in the hypothalamus of a patient, according to another embodiment of the invention;

FIG. 32 is a schematic representation of steps involved in a method for treating an obesity patient by placing a chronic electrical stimulator in the hypothalamus of the patient, according to another embodiment of the invention;

FIG. 33 schematically summarizes steps involved in a method for microinfusing a drug from at least one microinfusion catheter into the hypothalamus of a patient, according to another embodiment of the invention;

FIG. 34 is a schematic representation of steps involved in a method for treating an obesity patient by microinfusing a drug from at least one microinfusion catheter into the hypothalamus of the patient, according to another embodiment of the invention;

FIG. 35A is a schematic representation of steps involved in a method for treating an obesity patient by electrical stimulation of the hypothalamus of the patient, according to a preferred embodiment of the invention; FIG. 35B is a schematic representation of steps involved in a method for treating an obesity patient by microinfusing a drug from at least one microinfusion catheter into the hypothalamus of the patient, according to another embodiment of the invention; and FIG. 35C is a schematic representation of steps involved in a method for treating an obesity patient by microinfusing a drug from at least one microinfusion catheter into the hypothalamus of the patient, according to yet another embodiment of the invention;

FIG. 36A schematically shows steps involved in a method for treating an obesity patient by chronic electrical stimulation of the hypothalamus of the patient by implantation in the hypothalamus of a programmable hypothalamic obesity probe, according to a preferred embodiment of the invention; FIG. 36B schematically shows steps involved in a method for treating an obesity patient by chronic electrical stimulation of the hypothalamus of the patient by implantation in the hypothalamus of a pre-programmed chronic electrical stimulator, according to another embodiment of the invention.

DETAILED DESCRIPTION OF PREFERRED EMBODIMENTS

There now follows a description of a neural prosthesis apparatus, under the invention, as well as methods of using the same. There then follows a description of apparatus and methods for performing stereotactic manipulations, including magnetic surgery and targeted drug delivery, according to the invention. Subsequent thereto there follows a description of a hypothalamic obesity probe apparatus and methods for using the same for treatment of obesity in a patient, and a description of a hypothalamic drug microinfusion assembly and methods of using the same for treating an obesity patient.

Neural Prosthesis

Advanced imaging combined with an intraoperative stereotactic system now enable placement of penetrating electrodes into auditory cortex during routine epilepsy surgery without dissection of the Sylvian fissure.

Primary auditory cortex 150 in FIGS. 1A and 1B is tonotopically organized, meaning stimulation in different areas is likely to cause the patient to perceive different tones. These tones form the building blocks of complex sound phenomena such as speech. Tonotopic organization is a

fundamental characteristic of the cochlea and cochlear nucleus as well, as discussed above. Primary auditory cortex **150**, however, has its tonotopic map stretched across a larger volume of tissue (greater than twice the volume of cochlear nucleus **116**). Greater tissue volume enables placement of a greater number of electrical contacts for a given tonotopic zone. This results in increased signal resolution and improved clarity of auditory sensation. Finally, because of anatomical differences, primary auditory cortex **150** can accommodate penetrating electrode arrays which cannot be safely placed into the cochlear nucleus.

FIG. 2 shows a human cerebral cortex neural prosthetic **200** according to one embodiment of the invention. Prosthetic **200** has a first end **206a** and a second end **206b** which is blunt or smoothly curved. Prosthetic **200** has electrical contacts **220** along a longitudinal support **226**. Support **226** can be anywhere from several millimeters long to several centimeters long. Electrical contacts **220** are small metal pads which can be separately and independently electrically charged via respective wires **232** available at first end **206a**. Wires **232** have leads **238** which are coupled to a speech processor (not shown). Electrical contacts **220** are spaced approximately 10 micrometers to several millimeters apart and preferably approximately 50 to 150 micrometers apart. Application of a voltage to contacts **220** near first end **206a** results in stimulating low (or high—to be determined by questioning the patient) tones in primary auditory cortex **150** (see FIGS. 1A and 1B), whereas application of a voltage to contacts **220** near second end **206b** results in stimulation of high (or low) tones in primary auditory cortex **150**.

Longitudinal support **226** can be rigid or flexible. Prosthetic **200** may be introduced into a patient's brain via a rigid introducer, and subsequently electrical contacts **220** are exposed to primary auditory cortex **150**. Support **226** can be one of the probes shown in FIGS. 3–5 in "Possible Multi-channel Recording and Stimulating Electrode Arrays: A Catalog of Available Designs" by the Center for Integrated Sensors and Circuits, University of Michigan Ann Arbor, Mich., the contents of which are incorporated herein by reference. Alternative electrodes such as Depthalon Depth Electrodes and interconnection cables from PMT Corporation 1500 Park Road, Chanhassen, Minn., 55317 could also be used as support **226** and electrical couplers between contacts **220** and a speech processor (**410** in FIG. 4).

Electrical contacts **220** must operate as high impedance (megohms) contacts as opposed to low impedance (a few ohms to several thousand ohms) contacts. This makes it possible to output a greater potential for the contacts while outputting a small (a few microamperes as opposed to a few milliamperes) current. This also localizes the potentials applied to the patient's auditory cortex to approximately a few hundred micrometers. The localization of applied electric charges corresponds to the tonotopic spacing of nerve cell pairs.

Prosthetic **200** is arranged along a longitudinal direction of primary auditory cortex **150**. However, primary auditory cortex **150** is located in the transverse temporal gyro and is buried deep within the Sylvian fissure. Consequently, its location cannot be determined simply by looking at an exposed surface of the brain. Therefore, MRI imaging techniques must be employed to reveal the exact orientation of primary auditory cortex **150**.

A single coronal image of an individual's brain cannot reveal the exact orientation of primary auditory cortex **150**. Instead, a series of images must be obtained and a resulting 3-dimensional MRI image constructed. Once such an image is constructed, the digital data making up that image can be

transformed to provide a view of the Sylvian fissure. This in turn exposes primary auditory cortex **150** as a mound-like hump. That is, tissue on top of the digital image can be "peeled off" to expose the Sylvian fissure and consequently primary auditory cortex **150** "pops out" of the image. This process is described in "Three-dimensional In Vivo Mapping of Brain Lesions in Humans", by Hanna Damasio, MD, Randall Frank, the contents of which are incorporated herein by reference.

FIG. 3A shows a side view of a plane A which intersects a coronal section **310** as well as a view of coronal section **310** with Sylvian fissure **316** exposed. FIGS. 3B and 3C show coronal section **310** before and after tissue is digitally "peeled off" to expose primary auditory cortex **150**. One or more resulting mounds **320** is revealed in FIG. 3C and this mound corresponds to primary auditory cortex **150** of FIG. 1B. Mound **320** does not appear until after tissue on the underside of Sylvian fissure **316** is reconstructed to provide the 3-dimensional image.

Once the exact location and orientation of mound **320** and consequently primary auditory cortex **150** have been determined using these 3-dimensional MRI image processing techniques, the actual primary auditory cortex **150** can be surgically exposed and prosthetic **200** can be accurately inserted into primary auditory cortex **150**. FIG. 4 shows prosthetic **200** just prior to insertion into primary auditory cortex **150**. In addition, FIG. 4 shows a speech processor **410** coupled to leads **238** via coupling cable **414**. Examples of speech processors for speech processor **410** include Nucleus Device made by Cochlear Corporation. Speech processor **410** can be miniaturized and placed directly above ear **416** in the patient's mastoid. FIG. 4 also shows additional diagnostic equipment including an oscilloscope **420** coupled to prosthetic **200** via cable **424**.

FIG. 5 shows a prosthetic **510** which includes two longitudinal supports **226a** and **226b** according to another embodiment of the invention. Although two supports are shown, three or more such supports could be used. Longitudinal support **226a** has wires **232a** with corresponding leads **238a** and longitudinal support **226b** has wires **232b** and leads **238b**. Leads **238a** and **238b** are again connected to speech processor **410** as in FIG. 4. In addition, scope **420** can be used to observe signals output to longitudinal support **226a** and **226b**.

FIG. 6 shows a prosthetic **610** according to yet another embodiment of the invention. In particular, FIG. 6 shows longitudinal support rod **226** with first end **606a** and second end **606b**. End **606a** is arranged in the region of primary auditory cortex **150** with low tones (or high tones as previously discussed) and second end **606b** is arranged in the region of primary auditory cortex **150** with high (or low) tones in a manner similar to first end **206a** and second end **206b** of FIG. 2. Here, however, longitudinal support **226** has a sphere **616** which is stopped by a stopping piece **614**. This enables the physician to insert longitudinal support **226** at a wide range of angles and yet secure prosthetic **610** once longitudinal support **226** has been inserted.

FIG. 7A shows prosthetic **610** of FIG. 6 as looking down on the patient's brain surface **704**. FIG. 7B shows a closer view of stopping piece **614** with a cup **708** and a lid **714** with a notch **716** for passing leads **232**. FIG. 7C corresponds to FIG. 7A with support **226** inserted into surface **704** and sphere **616** resting in cup **708**. FIG. 7C also shows lid **714** covering sphere **616** with leads **232** extending out of notch **716**.

FIG. 8 shows a multicontact electrode apparatus **200** according to another embodiment of the invention, in which

longitudinal support **226** is equipped with a magnetic tip **133** at its distal end **206b**. The attribute of a magnetic tip allows for the introduction and directed movement of the prosthesis to the target tissue by the application of an external magnetic field, as described herein in connection with the disclosed apparatus for performing magnetic pallidotomy. Furthermore, the precise location of a magnetically tipped neural prosthesis, which has previously been inserted following 3-dimensional MRI imaging and surgical exposure of the auditory cortex, may be fine tuned by the application of a suitable external magnetic field (G. T. Gillies, et al., "Magnetic Manipulation Instrumentation for Medical Physics Research," Rev. Sci. Instrum., 65, 533-562 (1994)). In the latter case, the magnitude and direction of the applied magnetic field may be changed in response to the patient's auditory sensations following electrical stimulation of the auditory cortex.

Stereotactic Surgical Electrode Assembly

While all cells maintain an electrical potential across their membranes, nerve cells (neurons) are highly specialized in using membrane potentials (action potentials) to transmit signals from one part of the body to another. The action potential of a neuron represents a transient depolarization of its membrane over a period of a few milliseconds. Action potentials, in turn, have proved to be valuable indicators of the physiological status and functionality of those neurons. For example, in stereotactic pallidotomy the action potential of a neuron is used as the basis for determining whether to make a lesion at the site of the particular neuron.

Monopolar microelectrodes of the prior art comprise stiff wires which are electrically insulated except for a relatively short, sharpened tip. By keeping the length of the uninsulated tip short, an electrode with a high impedance (>1 megaohms) is obtained. A higher impedance microelectrode allows for a more precise measurement of action potentials relative to ground (using such prior art microelectrodes, typically the entire body of the patient is grounded). In contrast, electrodes with a larger area of exposed (uninsulated) surface are characterized by a lower impedance (a few to <1 megaohms). Consequently, larger electrodes with lower impedances ordinarily record voltage transients (field potentials) associated with larger volumes of tissue; but are unable to record action potentials from individual cells.

In accordance with an embodiment of this invention, it has now been discovered that action potentials can be accurately recorded from individual neurons using electrodes with a relatively large exposed surface area, and a relatively low impedance. Namely, action potentials of individual cells can be recorded using a microelectrode including a novel multipolar contact array. In a preferred embodiment, each microelectrode includes a pair of contacts (corresponding to a bipolar contact) in close juxtaposition, which are coupled to at least one differential amplifier (Bak Electronics, Germantown, Md.), and differential recordings are made from one contact relative to the other (instead of relative to patient ground as in the prior art). In another embodiment, each microelectrode may comprise tripolar contact arrays (stereotrodes, B. L. McNaughton, et al., "The stereotrode: a new technique for simultaneous isolation of several single units in the central nervous system from multiple unit recordings," J. Neurosci. Methods, 8:391-397, 1983.)

Dual purpose electrode assemblies bearing neuron-monitoring electrodes, according to the invention, are useful in carrying out a range of medical procedures. As will be apparent to the skilled artisan, electrode assemblies of the

instant invention are particularly useful for performing various stereotactic procedures on the brain. Such stereotactic procedures include various surgical procedures on specific regions of brain tissue, including stereotactic pallidotomy and stereotactic thalamotomy. Electrode assemblies under the invention may also be used for chronically inactivating a previously-monitored, specific region of a patient's brain tissue, without forming a lesion therein. In another embodiment, electrode assemblies of the instant invention are also useful in delivering one or more chemical agents to a previously-monitored, specific region of a patient's tissues. Such chemical agents may be either toxic chemicals (where inactivation of neurons is called for), or therapeutic drugs (where therapy is indicated).

A medical procedure performed on a patient's brain, according to the invention, will now be described in general terms. Following visualization of the target tissue by various imaging procedures well known in the art, a dual purpose electrode assembly **103** bearing at least one neuron-monitoring electrode **135** is introduced into the patient's brain in the vicinity of the target tissue via introducer tube **101**, as described herein. The positioning of the various parts of electrode assembly **103**, including electrode support shaft **137**, may then be fine-tuned as appropriate. Electrode potentials from cells or tissues may then be recorded and the physiological status of the cells or tissues is monitored, over a period of up to several days if necessary. Tissue at the site(s) of the monitored neuron(s) may then be treated. Treatment will vary depending on the patient's overall condition, and/or on the recordings of electrical potentials. For example, treatment may be in the form of reversible or irreversible inactivation of one or more cells or a region of tissue, or by the delivery of one or more therapeutic drugs.

Various embodiments of electrode assembly **103** of the instant invention will now be described, particularly in the context of performing stereotactic pallidotomy. Other applications and uses of the electrode assembly will be apparent to the skilled artisan, and are hereby stated to be within the scope of the invention, as delineated by the claims appended hereto.

Stereotactic Pallidotomy

The globus pallidus is a conical subcortical structure within the brain which is involved in the control of movement. FIG. 12A shows the gross morphology, and relative size of the globus pallidus, as well as its approximate location and orientation within the brain. During recent years, stereotactic pallidotomy has become recognized as a valuable procedure in the treatment of Parkinson's disease (see, for example, Laitinen, L. Y., et al., "Leksell's posteroventral pallidotomy in the treatment of Parkinson's disease," J. Neurosurg., 76:53-61, 1992; Iacono, R. P., et al., "The results, indications, and physiology of posteroventral pallidotomy for patients with Parkinson's disease," Neurosurgery, 36:1118-1127, 1995; and references cited therein.) Simply stated, the rationale for the success of this treatment is as follows. Parkinson's disease causes dysfunction due to loss of dopaminergic innervation in a part of the movement control circuit (Putamen and Caudate) distinct from the globus pallidus. However, because of the nature of the circuit, the dysfunction in Parkinson's disease can be ameliorated by disruption of the circuit at the point of the globus pallidus (see, for example, Laitinen, L. Y., et al., "Leksell's posteroventral pallidotomy in the treatment of Parkinson's disease," J. Neurosurg., 76:53-61, 1992; Iacono, R. P., et al., "The results, indications, and physiology of posteroventral

pallidotomy for patients with Parkinson's disease," *Neurosurgery*, 36:1118-1127, 1995; and references cited therein.)

FIG. 12C shows the parallel linear trajectories of electrode assemblies according to prior art pallidotomy. As shown, stereotactic pallidotomy techniques of the prior art have relied on the sequential insertion of first a microelectrode to monitor the physiologic response of neurons within a defined region of the globus pallidus, and, if the response calls for inactivation (lesioning) of neurons in that region, a second, larger, lesion-producing macroelectrode, or a cryogenic device, is targeted to the same site for the purpose of producing a lesion thereat. This process is repeated until a suitable number of sites within the globus pallidus have been monitored and, if appropriate, the neuron(s) at that site inactivated. A further feature of prior art pallidotomy is that the trajectories of the electrodes are perpendicular to the long axis of the globus pallidus (see for example FIG. 12C). Therefore, the prior art pallidotomy process outlined in the Background of the Invention section of this specification requires the surgeon to make several passes through normal brain tissues during the operation, with a concomitant risk of brain damage.

The instant invention is concerned with an apparatus including an electrode assembly including an electrode support shaft, in which electrode assembly 103 and electrode support shaft 137 are broadly equivalent to the multicontact prosthesis 200 and longitudinal electrode support 226, respectively, of the neural prosthesis described above. Differences between the recited parts of the respective devices will be readily apparent to the skilled artisan from their descriptions herein.

Electrode assembly 103 and electrode support shaft 137 of the instant invention may be either rigid or flexible. In a preferred embodiment, both electrode assembly 103 and electrode support shaft 137 are flexible. In one embodiment electrode support shaft 103 of the instant invention bears at least one neuron-monitoring electrode 135A/135B. In a preferred embodiment electrode support shaft 103 of the instant invention bears at least one bipolar neuron-monitoring microelectrode 135A. Preferably electrode support shaft 137 includes an outer sheath 143 constructed of a flexible polymeric or co-polymeric material. A particularly preferred sheath material includes tecoflex-polyurethane (Thermetics, Woburn, Mass.). Preferably electrode support shaft 137 bears a plurality of bipolar neuron-monitoring microelectrodes 135A, each bipolar microelectrode 135A including two electrical contacts 136, in the form of a pair of fine wires lying external to, and approximately parallel with, the external sheath of the shaft. Each electrical contact 136 is coupled to an electrical lead 129 including at least one strand of electrically conductive material, whereby a suitable electric current may be conducted to or from each of the electrical contacts 136. Preferably each electrical lead 129 includes a flexible wire coated with an electrically insulating material. More preferably each strand of electrically conductive material includes platinum and iridium, and has a diameter in the range of 10-200 micrometers, more preferably in the range of 20-100 micrometers and most preferably in the range of 30-70 micrometers. In a preferred embodiment the electrically insulating material coating each electrical lead includes polytetrafluoroethene (Teflon®). In another embodiment electrode support shaft 137 of electrode assembly 103 is flexible, bears a plurality of bipolar neuron-monitoring microelectrodes 135A, and is equipped with a magnetic tip 133 at its distal end. Magnetic tip 133 of the electrode support shaft 137 is responsive to an external magnetic field, thereby allowing for its maneuverability in response to

controlled changes in an applied magnetic field. The magnetic manipulation of medical devices within a patient's body, in general, including magnetic stereotactic procedures, is known in the art (see, for example Grady, M. S., et al. "Magnetic stereotaxis: a technique to deliver stereotaxic hypothermia," *Neurosurg.*, 27:1010-1016, 1990; Grady, M. S., et al., "Nonlinear magnetic stereotaxis: Three dimensional, in vivo remote magnetic manipulation of a small object in canine brain," *Med. Phys.*, 17:405-415, 1990; Gillies, G. T., et al., "Magnetic manipulation instrumentation for medical physics research," *Rev. Sci. Instrum.*, 65:533-562, 1994, and references cited therein.

In one embodiment of the invention, each bipolar microelectrode 135A is in the form of a pair of fine wires closely juxtaposed on electrode support shaft 137, and is capable of monitoring the activity of an individual neuron or cell by outputting electrical signals indicative of the physiological status of the particular neuron or cell. The physiological status of a neuron or cell may be used to determine whether to inactivate the particular neuron or cell.

Under the invention, neurons targeted for inactivation may be inactivated by a variety of different mechanisms and for various time periods. For example, neurons may be inactivated by exposure to radiation, infusion of a toxic chemical, cryogenic treatment (cooling), or prolonged electrical stimulation. A toxic chemical, under the invention, may be a chemical known to be a neurotoxin or a broad spectrum cytotoxin. Cryogenic treatment may be administered from at least one miniaturized cryogenic device located at one or more specific sites on the electrode support shaft. A preferred mechanism for inactivating neurons is by exposure to radio frequency (RF) radiation, using, for example, a RF lesion generator system such as model RFG-3C manufactured by Radionics (Burlington, Mass.). These examples should not be considered to limit the invention as defined by the claims in any way.

Inactivation of neurons may be reversible or irreversible. In general, inactivation of neurons resulting from cooling or electrical stimulation is, to some extent, reversible; whereas neuron inactivation by exposure to radiation or infiltration of a toxic chemical normally results in a permanent lesion and is irreversible.

In a preferred embodiment, electrode support shaft 137 is flexible, is equipped with a magnetic tip 133 responsive to an applied external magnetic field, and bears a plurality of neuron-monitoring microelectrodes 135A and a plurality of neuron-inactivating sites positioned along electrode support shaft 137. In a more preferred embodiment, electrode support shaft 137 is flexible, is equipped with a magnetic tip 133 responsive to an applied external magnetic field, and bears a plurality of bipolar neuron-monitoring microelectrodes 135A and an equal number of neuron-inactivating sites positioned along electrode support shaft 137, wherein each of the plurality of bipolar neuron-monitoring microelectrodes 135A is positioned, along the longitudinal axis of electrode support shaft 137, coincidental with one of the neuron-inactivating sites. Each neuron-inactivating site is capable of inactivating one or more neurons located adjacent to that site. A plurality of bipolar neuron-monitoring microelectrodes 135A may be located at different points on the circumference of electrode support shaft 137, in other words, the position of the microelectrodes may be offset with respect to the long axis of the electrode support shaft. In another embodiment of the dual purpose electrode support shaft 137, a plurality of bipolar neuron-monitoring microelectrodes 135A may be located at different points on the circumference of electrode support shaft 137 but at the

same longitudinal position on the support shaft. For example, two bipolar neuron-monitoring microelectrodes **135A** may be diametrically opposed, as shown in FIG. **11B**. This latter arrangement allows for the simultaneous recording of two action potentials, one from each side of the support shaft. In one embodiment of the invention, each neuron-inactivating site on electrode support shaft **137** is in the form of a delivery port **141** for releasing a lesion-producing toxic chemical. Each delivery port **141** may be activated to release a measured dose of a toxin to the neuron(s), cell(s), or tissue targeted for inactivation, thereby inducing a localized lesion thereat. Many cytotoxic chemicals are known in the art, and may be used either alone (unconjugated), or conjugated to a specific monoclonal antibody or other carrier molecule (see, for example Stan, A. C., et al., "In vivo inhibition of angiogenesis and growth of the human U-87 malignant glial tumor by treatment with an antibody against basic fibroblastic growth factor," *J. Neurosurg.*, 82:1044-1052, 1995.) One example of a cytotoxic chemical is ibotenic acid which selectively destroys cell bodies without damaging fibers of passage (Guldin, W. O. & Markowitsch, H. J., "No detectable remote lesions following intrastriatal injections of ibotenic acid," *Brain Res.*, 225: 446-451, 1992).

In another embodiment of the invention, each neuron-inactivating site on electrode support shaft **137** is in the form of a macroscopic stimulating electrode capable of chronic electrical stimulation of the neuron(s), cell(s), or tissue targeted for inactivation, thereby inducing localized, transient neuron dysfunction. With this type of treatment neuron function is generally regained some time after cessation of electrical stimulation.

In a further embodiment of the invention, each neuron-inactivating site on electrode support shaft **137** is in the form of a cryogenic device, i.e. an element which causes localized cooling of those neurons or tissues with which it is in physical contact. Generally, neuron inactivation resulting from cooling is reversible, and neuron function is restored after a period of time following cessation of treatment.

In another embodiment of the invention, each neuron-inactivating site on electrode support shaft **137** is in the form of a lesion-producing macroelectrode **139**, which when energized delivers radio frequency (RF) energy to the neuron(s), cell(s), or tissue targeted for inactivation, thereby inducing a localized lesion thereat.

Although neuron inactivation is described herein primarily with reference to lesion production via macroelectrodes **139**, this should not be considered as limiting the scope of the invention in any way.

A flexible embodiment of electrode assembly **103** can be initially introduced into the vicinity of the target tissue, such as the globus pallidus, via introducer tube **101** that has previously been stereotactically inserted into the patient's brain. Introducer tube **101** of the instant magnetic pallidotomy device is equivalent to the introducer described above in connection with neural prosthesis **200**. Once inserted in the patient's brain, the magnetic tip **133** of electrode assembly **103** may be urged forwards by the application of an external magnetic field of suitable magnitude and direction. By changing the magnitude and direction of the magnetic field electrode support shaft **137** can be directed forwards to varying extent and in different directions so that it occupies the desired conformation within the target tissue. In this situation, electrode support shaft **137** can be the to be "draped" within the target tissue. Preferably the magnetic field is generated by an electromagnet or multi-coil electromagnet system positioned adjacent to, or

surrounding, the head or other appropriate body part of the patient. The electromagnet or multi-coil electromagnet system may be attached to a robotic arm. One or more computers may be used to control movement of the robotic arm, and the magnitude and direction of the magnetic field, as well as to visualize the location and movement of the magnetic device within the patient.

The manipulation of magnetic medical devices within the body by the application of a magnetic field is described more fully in U.S. Pat. No. 4,869,247 and U.S. Pat. No. 5,125,888 both of which are incorporated by reference herein in their entirety. Reference is also made to the following publications: Howard III, M. A., et al., "Magnetic movement of a brain thermoreceptor," *Neurosurgery*, 24: 444-448, 1989; Grady, M. S., et al. "Magnetic stereotaxis: a technique to deliver stereotaxic hypothermia," *Neurosurg.*, 27:1010-1016, 1990; Grady, M. S., et al., "Nonlinear magnetic stereotaxis: Three dimensional, in vivo remote magnetic manipulation of a small object in canine brain," *Med. Phys.*, 17:405415, 1990; Gillies, G. T.; et al., "Magnetic manipulation instrumentation for medical physics research," *Rev. Sci. Instrum.*, 65: 533-562, 1994; and references cited therein.

Once the neurons adjacent to neuron-monitoring electrodes **135A/135B** and macroelectrodes **139** have been monitored and subsequently inactivated, if appropriate, electrode assembly **103** may be withdrawn to a home position within introducer tube **101** by exerting a pulling force on tether line **127**. Electrode support shaft **137** may then be reintroduced into the patient and repositioned within the patient's tissues, for example, to sample additional regions within the globus pallidus. As electrode assembly **103** is reintroduced into the patient, tether line **127** retracts but its proximal end is retained within the end piece **113** of introducer tube **101** by anchor plate **125** which is fixedly attached to the proximal end of tether line **127**.

Referring now to the drawings, in which like reference numerals designate like or corresponding elements throughout, there is shown in FIGS. **9-11, 13-17, 20** and **23** various elements, components or embodiments of an apparatus for introducing the distal end of at least one electrode assembly **103** into the tissues of a patient. FIGS. **9A, 9B** and **9C** illustrate three different embodiments of an electrode support shaft, in which support shaft **137** may be rigid (as depicted in FIGS. **9A** and **9B**) or flexible (as shown in FIG. **9C**). Preferably support shaft **137** bears at least one bipolar neuron-monitoring microelectrode **135A** and at least one macroelectrode **139**. Support shaft **137** may have additionally magnetic tip **133** as shown in FIG. **9C**.

FIG. **10** shows an electrode support shaft **137** having a magnetic tip **133** and bearing a plurality of bipolar neuron-monitoring microelectrodes **135A**. Positioned adjacent to each neuron monitoring microelectrode **135A** is a neuron-inactivating site.

FIGS. **11A** and **11B** show details of parts of an embodiment of an electrode support shaft **137** of a dual purpose electrode assembly **103**, bearing bipolar neuron-monitoring microelectrodes **135A**, in which the pair of electrical contacts **136** of microelectrodes **135A** are closely juxtaposed, and are positioned coincidental with, and external to, macroelectrode **139**.

FIGS. **13A-13C** show apparatus for performing magnetic stereotactic surgery. FIG. **13A** shows introducer tube **101** positioned within the patient's skull. Electrode assembly **103** is passed through introducer tube **103** towards the targeted tissue. FIG. **13B** shows the electrode assembly **103** ex situ. Electrode assembly **103** includes tether line **127**,

35

anchor plate 125, electrical leads 129 gathered at rubber exit cuff 131, and at its distal end, electrode support shaft 137. FIG. 13C shows electrode assembly 103 housed within introducer tube 101 with sealing cap 119 unattached.

FIG. 14 shows a general cross sectional view of introducer tube 101. Introducer tube 101, may be flexible or rigid in its construction, and includes elongate cylindrical portion 105 with an open distal end 107, conical neck portion 109 which is continuous with portion 105, and at the proximal end 111 of introducer tube 101 is located a short cylindrical end piece 113 continuous with neck portion 109.

In a preferred embodiment the inner wall 115 of introducer tube 101 may be coated with a physiologically acceptable fluid, prior to the introduction of electrode assembly 103, in order to serve as a lubricant and to reduce drag on electrode assembly 103 as it travels within introducer tube 101.

FIG. 15 shows a more detailed view of the proximal end of introducer tube 101 showing electrode assembly 103 positioned substantially within introducer tube 101, and with sealing cap 119 (not shown) unattached. From this position, electrode support shaft 137 may be moved from introducer tube 101 to target tissues and returned to introducer tube 101.

FIG. 16 shows a more detailed view of the proximal end or neck portion 109 of introducer tube 101 with sealing cap 119 attached, in which the inner wall 115 of end piece 113 has a seat 117 to accommodate sealing cap 119. Docking platform 121 is rigidly attached to the inner wall 115 of introducer tube 101. Docking platform 121 includes a perpendicular retaining wall 123 located at the perimeter of platform 121. Anchor plate 125 attached to tether line 127 is retained on docking platform 121 before and during insertion of electrode support shaft 137 into the target tissue. However, to return electrode assembly 103 from the patient to introducer tube 101, anchor plate 125 may be grasped with forceps via the handle 126 of anchor plate 125, and an upward force may then be applied to tether line 127.

Docking platform 121 may be located at different positions along the longitudinal axis of introducer tube 101 within the neck portion 109, provided that the handle 126 of anchor plate 125 is accessible to the surgeon and there is provided sufficient clearance for sealing cap 119 to be seated in the fully closed position.

Electrical leads 129, having rubber exit cuff 131, exit introducer tube 101 in the region of end piece 113 approximately diametrically opposite the location of docking platform 121.

FIG. 17 depicts a part of the distal end of an electrode assembly 103 according to a preferred embodiment of the invention, in which electrode support shaft 137 is positioned within the globus pallidus. Electrode assembly 103 has a magnetic tip 133 located at the distal end of electrode support shaft 137, and a plurality of bipolar neuron-monitoring microelectrodes 135A positioned along the long axis of electrode support shaft 137. Each bipolar neuron-monitoring microelectrode 135A is capable of monitoring the physiologic activity of an individual neuron by sensing electrical signals and outputting the sensed signals to a suitable recording means. Preferably, each bipolar neuron-monitoring microelectrode 135A is constructed of a pair of closely juxtaposed electrical contacts 136. Each electrical contact includes a fine wire having a diameter in the range of 5 to 200 micrometers, more preferably in the range of 5 to 100 micrometers, and most preferably in the range of 10 to 40 micrometers. Adjacent to each bipolar neuron-monitoring microelectrode 135A is located a corresponding,

36

spatially paired, lesion-producing macroelectrode 139. Preferably, the fine wires including electrical contacts 136 of bipolar microelectrodes 135A are sufficiently flexible to “flow” with each pulsation of the brain tissue, and thereby avoid disturbances in the surrounding tissues. In contrast, monopolar neuron-monitoring microelectrodes of the prior art are shorter and stiffer than those of the instant invention, which result in disruption of surrounding tissues and consequently must be removed within a relatively short period of time. The flexible, non-disrupting nature of bipolar microelectrodes 135A as described herein allows them to remain in situ for an extended period of time, thereby enabling the accumulation of more meaningful information on the physiological status of the particular neurons being monitored. Such information is critical in defining exactly where neuron inactivation should be performed; this, in turn, leads to maximum efficacy in the treatment and minimum complications for the patient.

According to a preferred embodiment of the invention, a magnetically tipped dual purpose multicontact electrode assembly 103 is inserted into introducer tube 101, and electrode assembly 103 is anchored to the inner wall 115 of introducer tube 101 via tether line 127 and anchor plate 125. The outside diameter of the electrode support shaft 137, including magnetic tip 133, is in the range of 1 to 4 mm, which is in the range of currently used standard stereotaxic biopsy tools. There is sufficient excess length or slack in electrode assembly 103 and in the attached electrical leads 129 and tether line 127 so that the electrode-bearing region of electrode assembly 103 can be pulled out of introducer tube 101 into the target tissue by a suitably applied external magnetic field. Under computer control, the magnetic tip 133 of electrode assembly 103 is driven into the target tissue along a preselected trajectory.

FIG. 18 depicts the movement of a magnetically tipped electrode assembly 103 in the direction away from introducer tube 101 towards the apex of the globus pallidus. The magnetic tip 133 is directed along the selected trajectory by appropriate changes in the magnitude and direction of an applied external magnetic field.

FIG. 19 shows steps in performing magnetic pallidotomy using a dual purpose multicontact electrode assembly 103, in which introducer tube 101 is first inserted into the patient's skull in step a), electrode assembly 103 is introduced into introducer tube 101 in step b), electrode assembly 103 is located in the “home” position within introducer tube 101 in step c), electrode support shaft 137 of electrode assembly 103 is directed into the globus pallidus by magnetic movement in step d), sealing cap 119 is placed on end piece 113 of introducer tube 101 in step e), electrode support shaft 137 of electrode assembly 103 is returned to the “home” position within introducer tube 101 in step f), and electrode assembly 103 is removed from the patient in step g). In the case of the globus pallidus, the preferred trajectory for movement of electrode support shaft 137 generally runs along its entire longitudinal axis, and movement of the magnetic tip 133 to the end of the selected trajectory should take about 20 minutes. Sealing cap 119 can then be attached to the end piece 113 of introducer tube 101, thereby sealing introducer tube 101 at its proximal end 111.

The patient may now be removed from the magnetic surgery suite and returned to the hospital ward. A number of globus pallidus neurons may now be monitored for their physiologic activity, and the activity monitored by each microelectrode 135 may be recorded using a suitable recording device. Based on the neuronal activity monitored and on

physiologic criteria, a decision can be made whether to inactivate the particular neuron(s) under study.

If inactivation of a particular neuron is called for, a lesion may be made by energizing the appropriate lesion-producing macroelectrode(s) **139** with a suitable electric current. Preferably, the energy used to produce lesions is in the radio frequency (RF) range. The functional consequences of neuron inactivation can then be assessed by testing the patient on the hospital ward. If the results are satisfactory, the electrode assembly **103** may be removed. Alternatively, it may be desirable to monitor other neurons which are located at different regions within the globus pallidus. In the latter case sealing cap **119** is first removed from introducer tube **101**.

As depicted in FIG. **20**, the handle **126** of anchor plate **125** may be grasped with forceps and an upward force exerted on tether line **127**, whereby electrode assembly **103** is "reloaded" or returned to the home position within introducer tube **101**. The magnetic tip **133** of electrode assembly **103** may now be redirected, again by the application of a suitable external magnetic field, along a second preselected trajectory until it once again occupies the desired conformation within the target tissue. The process of monitoring and selectively inactivating individual neurons may then be repeated. A method for performing pallidotomy according to one embodiment of the instant invention is illustrated by way of Example 1.

FIG. **21** shows steps in making a dual purpose multicontact electrode assembly useful in performing magnetic stereotactic surgery, wherein there is provided in step a) an electrode support shaft **137** bearing electrical leads **129** for coupling to bipolar microelectrodes **135A** and macroelectrodes **139**, a plurality of bipolar microelectrodes **135A** are attached to electrode support shaft **137** in step b), each of a plurality of macroelectrodes **139** is attached to electrode support shaft **137** adjacent to each of the plurality of bipolar microelectrodes **135A** in step c), a magnetic tip **133** is affixed to electrode support shaft **137** in step d), tether line **127** and anchor plate **125** are attached to electrode support shaft **137** at a position on **137** remote from the bipolar microelectrodes **135A** and the macroelectrodes **139** in step e), and rubber exit cuff **131** encompasses electrical leads **129** in step f).

FIG. **22** shows steps in making introducer tube **101**, wherein there is provided an elongate cylinder **105** in step (i), first narrower end of conical neck portion **109** is rigidly attached coaxially to elongate cylinder **105** in step (ii), cylindrical end piece **113** is rigidly attached coaxially to second broader end of conical neck portion **109** in step (iii), docking platform **121** including retaining wall **123** is rigidly attached to the inner wall of cylindrical end piece **113** in step (iv), and sealing cap **119** is provided in step (v).

Targeted Delivery of Therapeutic Drugs

One embodiment of a dual purpose stereotactic electrode assembly **103**, under the invention, may be used to deliver a measured dose of one or more therapeutic drugs to specific regions of tissues or organs undergoing treatment. In this regard, one or more cells within such regions of tissues, or such regions of tissue themselves, may have been previously monitored for their physiological activity, by means of at least one monitoring electrode **135** mounted on electrode support shaft **137** of electrode assembly **103**, prior to drug delivery. Thus, monitoring electrodes **135** on electrode support shaft **137** may be multipolar microelectrodes **135A** which are capable of monitoring action potentials from individual cells, or they may be monopolar electrodes **135B** capable of recording field potentials from a region of tissue.

The dual purpose cell monitoring/drug delivering electrode assembly embodiment of the invention is particularly useful for delivering a measured dose of a therapeutic drug to a region of previously-monitored tissue within the human brain. Such an electrode assembly **103** may be used, for example, in the treatment of epilepsy by the release of a therapeutic drug to specific regions of the cerebral cortex following monitoring of those regions with monitoring electrodes.

Referring now to FIG. **23**, there is provided a dual purpose electrode support shaft **137** of an electrode assembly **103**, bearing a plurality of monitoring electrodes **135** and a plurality of delivery ports **141**, which is capable of both monitoring the physiological activity of individual cells or tissues, and delivering a therapeutic drug to a specific site within a patient's tissues. Such an electrode support shaft, and the electrode assembly as a whole, is particularly suited to delivering a therapeutic drug to a specific site within a patient's brain. In one embodiment, such a dual purpose electrode support shaft **137** bears at least one bipolar neuron-monitoring microelectrode **135A** capable of monitoring action potentials from individual neurons, and has at least one delivery port **141** capable of releasing a therapeutic drug. In another embodiment, a dual purpose electrode support shaft **137** bears at least one monopolar neuron-monitoring electrode **135B** capable of monitoring field potentials from regions of brain tissue, and has at least one delivery port **141** capable of releasing a therapeutic drug. In yet another embodiment, a dual purpose electrode support shaft **137** bears at least one bipolar neuron-monitoring microelectrode **135A** capable of monitoring action potentials from individual neurons, and further bears at least one monopolar electrode **135B** capable of monitoring field potentials from regions of brain tissue, and has at least one delivery port **141** capable of releasing a therapeutic drug.

The drug-delivering embodiments of the electrode support shaft **137** may be used, under the invention, as an integral part of a flexible, multicontact, dual purpose, magnetically tipped electrode assembly **103**, substantially as described above in the context of stereotactic pallidotomy, and may be similarly used in conjunction with introducer tube **101**, also described above. The procedures of introducing and positioning electrode support shaft **137** within the target tissue may be performed substantially as described above in the context of magnetic stereotactic surgery, under the invention, and/or according to prior art stereotactic medical procedures.

The method of infusing drugs through small openings in the brain catheter would be similar to that described by Lieberman, et al. (Lieberman, et al., "Convection-enhanced distribution of large molecules in gray matter during interstitial drug infusion," J. Neurosurg., 82:1021-1029, 1995.)

Delivery ports **141** may be positioned along support shaft **137** in a defined spatial relationship with neuron-monitoring electrodes **135A/135B** to permit accurate delivery of the drug to the target tissue.

Each drug delivery port **141** may be coupled to at least one drug delivery supply line **145**, and each supply line may be connected, through a valve to a suitable mechanism for delivering a liquid. For example, surgical tubing, valves, and pumps known in the art may be used, or adapted for use, in conjunction with the apparatus of the instant invention. A suitable liquid delivering mechanism may in turn be connected to a variable volume reservoir for storing a suitable dose of a therapeutic drug to be delivered during treatment of the target tissue. Drug delivery may then be enacted by the simple expedient of opening the valve and activating a

pump, until the reservoir is emptied, or until a suitable measured dose has been released. Each variable volume reservoir and pumping means may be linked to a single delivery port **141**, or to a plurality of delivery ports **141**. In the latter case, by selectively activating the valve which controls fluid flow to each delivery port **141**, the exact site(s) of drug delivery can be controlled.

Referring now to FIG. **25**, there is shown one embodiment of a dual purpose neuron-monitoring/drug delivery electrode support shaft, bearing a plurality of multipolar neuron-monitoring microelectrodes **135A**, and an equal number of spatially paired drug delivery ports **141**. Each drug delivery port **141** is connected via a drug delivery supply line **145** to a reservoir/pump unit **147** for storing and dispensing a drug. The plurality of drug delivery supply lines **145** are distributed to their respective plurality of reservoir/pump units **147** by way of a drug delivery supply line manifold cap **148** located towards the proximal end of electrode assembly **103**. The location of a plurality of drug delivery supply lines **145** within the hollow body of the electrode support shaft **137** is shown in FIGS. **26A**, **26B**.

The dual purpose neuron monitoring/drug delivery electrode assembly **103** described above may be used to administer therapeutic drugs to patients suffering from various disorders of the brain, including both chronic (e.g. epilepsy) and acute (e.g. cerebral aneurysm) conditions. For example, in the case of medically refractory epilepsy, the dual purpose neuron-monitoring/drug delivery electrode assembly **103** including a flexible magnetically tipped electrode support shaft **137** may be inserted through a burr hole in the patient's skull via introducer tube **101**, such that the magnetic tip **133** of support shaft **137** is approximately in a desired location within the patient's skull. In the magnetic surgery suite, electrode support shaft **137** may be magnetically manipulated under computer control until it occupies the desired position. The location of neuron-monitoring electrodes **135A/135B** may be documented in a post-implantation imaging study. Once electrode support shaft **137** is suitably positioned, acute intraoperative monitoring of neurons in contact with electrodes **135A/135B** may be undertaken. Alternatively, the patient may be taken from the magnetic surgery suite to the epilepsy monitoring unit, and the physiological activity of a number of neurons may then be monitored chronically, using multipolar microelectrodes **135A**, over a period of a number of days. All data generated during this time can be stored using a multichannel tape recorder (Racal, Herndon, Va.), and may be analyzed off-line in the laboratory. Based on the data thus obtained and on criteria of physiologically normal parameters, an informed decision can be made as to whether drug treatment is indicated, and if so, the optimum treatment regime (nature of the drug, dosage, etc.) to be followed. Subsequently an appropriate dose of one or more therapeutic drugs may be selectively released from one or more drug delivery ports **141** positioned on electrode support shaft **137**.

The functional consequences of drug treatment may be assessed either in the epilepsy monitoring unit prior to removal of the dual purpose electrode assembly **103**, or subsequently. If, after assessing the patient, further treatment is indicated, either an additional dose of the same drug, or a first dose of a different drug, may be administered to those neurons that have already been monitored. Further, if patient assessment in the epilepsy monitoring unit indicates that it is desirable to monitor, and potentially administer a therapeutic drug to, additional neurons located at a different site of the cerebral cortex, electrode assembly **103** may be retracted into introducer tube **101**, and the patient returned

to the magnetic surgery suite. The above process may be repeated until a satisfactory result is achieved. A method for targeted delivery of therapeutic drugs to a patient, according to one embodiment of the invention, is described in Example 2.

As will be readily apparent to the skilled artisan, epilepsy treatment may also be performed by the selective inactivation of previously monitored neurons or regions of brain tissue, substantially according to the methods and apparatus, under the invention, described herein in the context of stereotactic pallidotomy. As discussed above, neuron inactivation may be effected by various treatments, including irradiation, treatment with a toxic chemical, cryogenic treatment and chronic electrical stimulation.

Hypothalamic Obesity Probe

There now follows a description of a hypothalamic obesity probe apparatus according to one embodiment of the invention, as well as methods of using the same.

FIG. **27A** shows a perspective view of a hypothalamic stimulation trials electrode assembly or hypothalamic obesity probe (HOP) **1101** according to one embodiment of the invention. HOP **1101** is for stereotactic placement in the hypothalamus of an obesity patient, and includes a macrocatheter **1103** which may house at least one electrode support shaft **1105**. Each electrode support shaft **1105** may be fine caliber to very fine caliber.

Each of the at least one electrode support shafts **1105** bears a plurality of electrical contacts **1107** arranged longitudinally on each electrode support shaft **1105**. Preferably each of the plurality of electrical contacts **1107** is arranged on each electrode support shaft **1105** in such a manner that plurality of electrical contacts **1107** do not protrude from electrode support shaft **1105**. Each of the plurality of electrical contacts **1107** may have its own electrical lead, and can be independently controlled. Each of the plurality of electrical contacts **1107** is electrically coupled to an electrical stimulation device (not shown). The electrical stimulation device allows for transmission of electrical signals to each of the plurality of electrical contacts **1107**. Further, each of the plurality of electrical contacts **1107** may be capable of independently outputting electrical discharges to the hypothalamus. The FOP may be programmed to determine: which of the plurality of electrical contacts **1107** output electrical discharges, when electrical discharges are output from the plurality of electrical contacts **1107**, and also the frequency of the electrical discharges outputted from the plurality of electrical contacts **1107**.

Each electrical contact **1107** may function as a monopolar stimulation electrode; or according to another embodiment, each pair of electrical contacts **1107** may function as a bipolar stimulation electrode. By "stimulation electrode" is meant one or more electrical contacts which is/are capable of transmitting or delivering electrical discharges, to nearby neurons, at either a relatively low frequency or a relatively high frequency, wherein the electrical discharges may cause either excitation (activation) or inhibition of the nearby neurons. Analogously, by "stimulating" neurons is meant a process or step for delivering one or more electrical discharges from one or more electrical contacts to one or more nearby neurons, the one or more electrical discharges at either a relatively low frequency or a relatively high frequency, wherein the one or more electrical discharges may cause either excitation (activation) or inhibition of the nearby neurons.

Electrical discharges of relatively low frequency (e.g. circa 50 Hz) and those of relatively high frequency (e.g.

circa 200 Hz) are expected to have opposite functional effects on nearby neurons: excitation and inhibition of surrounding tissue, respectively. This is directly relevant to the use of the HOP as an electrode assembly for performing stimulation trials on the manipulation of hypothalamic function as a means for regulating the appetite of an individual, i.e. the HOP is used to test the effect on appetite control of variable electrical stimulation frequencies in different regions of the hypothalamus. Thus, if an inhibitory electrical discharge (of relatively high frequency) is delivered to neurons in a portion of the hypothalamus that functions to increase appetite, a decrease in appetite may result. Similarly, if an excitatory electrical discharge (of relatively low frequency) is delivered to neurons in a portion of the hypothalamus that functions to decrease appetite, a decrease in appetite will once again be expected. Consequently, the concept of multi-frequency electrical stimulation of the hypothalamus associated with the HOP provides two optional approaches to curbing the appetite of an obesity patient, and at the same time increases the likelihood of finding regions of the hypothalamus which are responsive to appetite control via electrical stimulation. The likelihood of finding regions of the hypothalamus which are responsive to appetite control via electrical stimulation may be further increased by the use of a plurality of electrode support shafts **1105**, as well as by the use of a plurality of electrical contacts **1107** arranged longitudinally on each of the electrode support shafts **1105**.

Thus, stimulation trials hypothalamic electrode assembly or HOP **1101**, as described above, may be introduced via an introducer tube (not shown in FIG. 27A) through a burr hole in the patient's cranium to a location adjacent the hypothalamus, whence at least one electrode support shaft may be inserted in the hypothalamus. According to a preferred embodiment of the invention, a plurality of electrode support shafts may be inserted in the hypothalamus. By monitoring the clinical effect of electrical discharges of different frequencies and from different stimulation electrodes located in different selected portions or regions of the hypothalamus, the neurosurgeon may determine which portions of the hypothalamus are likely to provide a clinically useful result (i.e. the long term suppression of appetite of the obesity patient) following chronic electrical stimulation. The HOP may then be programmed to provide electrical discharges of suitable frequencies, periodicities, etc. from selected stimulation electrodes, in order to mimic or duplicate the monitored clinical effects on appetite suppression.

Alternatively, according to another embodiment of the invention, by monitoring the clinical effect of electrical discharges of different frequencies and from different stimulation electrodes located in different selected portions or regions of the hypothalamus, the neurosurgeon may determine an appropriate region of the hypothalamus in which to position a chronic electrical stimulation device (not shown) for the long term suppression of appetite of the obesity patient. Such a chronic electrical stimulation device may be pre-programmed prior to insertion in the hypothalamus to provide electrical discharges of suitable frequencies, periodicities, etc. in order to mimic or duplicate the clinical effects of appetite suppression as observed following electrical stimulation using the HOP.

According to a preferred embodiment of HOP **1101**, **1101'** (FIG. 27B), each stimulation electrode or electrical contact **1107** is capable of independently outputting electrical discharges in the frequency range of from about 10 to about 400

Hz, i.e. spanning the entire frequency range of electrical discharges from relatively low frequency to relatively high frequency.

Macro catheter **1103** may house from one electrode support shaft **1105** to dozens of electrode support shafts **1105**. Preferably macro catheter **1103** may house from two to about **10** electrode support shafts **1105**. Each electrode support shaft **1105** includes a plurality of stimulation electrodes or electrical contacts **1107**. Preferably, the HOP of the invention includes a sufficient number of electrode support shafts and a sufficient number and arrangement of stimulation electrodes **1107** that the entire hypothalamus can be mapped during a single insertion of the macro catheter into the brain of the patient. By mapping of the hypothalamus is meant monitoring the response of different regions of the hypothalamus to electrical discharges from stimulation electrodes. Each stimulation electrode **1107** may be coupled to a single electrical stimulation device (not shown) by electrical leads **1106**.

FIG. 27B shows a HOP or stimulation trials electrode assembly **1101'**, according to another embodiment of the invention, in which macro catheter **1103** may include a magnetic unit **1104** secured thereto to permit magnetic stereotactic placement of macro catheter **1103** at a predetermined location within the patient's brain. Preferably, the predetermined location for placement of macro catheter **1103** within the patient's brain is adjacent to the hypothalamus. In a preferred embodiment, magnetic unit **1104** is secured at the distal end of macro catheter **1103**. In one embodiment, magnetic unit **1104** is in the form of a magnetic collar secured at the distal end of macro catheter **1103**.

FIG. 28A shows a cross-sectional view of the distal end of a single electrode support shaft **1105** of HOP **1101**, according to one embodiment of the invention, in which two electrical contacts **1107** are each separately coupled via electrical leads to an electrical stimulation device (not shown), and each electrical contact **1107** functions separately as a monopolar stimulation electrode.

FIG. 28B shows a cross-sectional view of the distal end of a single electrode support shaft **1105** of HOP **1101** with two bipolar electrodes, including a total of four electrical contacts **1107** each separately coupled via electrical leads to an electrical stimulation device (not shown), according to another embodiment of the invention.

Hypothalamic Drug Microinfusion Assembly

There now follows a description of a hypothalamic drug microinfusion assembly according to another embodiment of the invention, as well as methods of using the same.

FIG. 29A shows a perspective view of a hypothalamic drug infusion assembly **1001**, according to another embodiment of the invention. Drug infusion assembly **1001** includes a macro catheter **1003** which may house at least one microinfusion catheter **1005** for placement in the hypothalamus. Each microinfusion catheter **1005** may be finely calibrated to very fine calibrated diameter.

Each of the at least one microinfusion catheters **1005** is functionally coupled to a drug delivery manifold **1009**. A drug supply line **1011** is functionally coupled to drug delivery manifold **1009**, and a drug reservoir/pump **1013** for retaining and pumping a drug is functionally coupled to drug supply line **1011**. Each of the at least one microinfusion catheters **1005** may have a plurality of drug delivery ports **1007** (FIG. 30).

While in use, drug reservoir/pump **1013** is located subcutaneously and adjacent to the cranium. Drug reservoir/pump **1013** pumps a drug at a variable rate, and the variable

rate of pumping a drug may be controlled percutaneously by a radio control unit (not shown), the latter well known in the art. Drug reservoir/pump **1013** may include a valve **1015**, such as a recharge valve for recharging reservoir/pump **1013** with a quantity of a drug. The term “drug” as used herein means any chemical entity, whether natural, synthetic, or semisynthetic, or derivatives thereof, which exhibit a pharmacological effect related to appetite regulation, and may include various neurotransmitters and regulatory molecules. According to a preferred embodiment of the invention, valve **1015** may be accessible externally or percutaneously.

FIG. **29B** shows a perspective view of a hypothalamic drug infusion assembly **1001'**, according to another embodiment of the invention. Drug infusion assembly **1001'** is similar to drug infusion assembly **1001**, with the exception that the former includes a magnetic unit **1004**. According to a currently preferred embodiment, magnetic unit **1004** is located at the tip or distal end of macrocatheter **1003** as a collar secured to the perimeter of macrocatheter **1003**. Magnetic unit allows for the magnetic stereotactic placement of macrocatheter **1003** at a specific location within the brain, for example placement at a location adjacent to the hypothalamus.

FIG. **30** shows a perspective view of the distal end of macrocatheter **1003** of hypothalamic drug infusion assembly **1001**, showing three microinfusion catheters **1005** protruding therefrom, according to one embodiment of the invention. It is to be understood that, whereas three microinfusion catheters **1005** are depicted in FIG. **30**, the actual number of microinfusion catheters **1005** housed within macrocatheter **1003** could be greater or lesser than three, or may equal three. Each microinfusion catheter **1005** includes a plurality of drug delivery ports **1007**. Each drug delivery port **1007** may be fine caliber to very fine caliber. Each of the plurality of drug delivery ports **1007** is independently controllable and capable of independently outputting a drug; and each of the plurality of drug delivery ports **1007** is therefore capable of independently delivering a drug to a separate site within the hypothalamus of a patient. The amount of drug outputted from the plurality of drug delivery ports **1007** is determined by reservoir/pump **1013**, the latter capable of pumping a drug at a variable pumping rate which may be controlled percutaneously by radio control as discussed hereinabove.

FIG. **31** summarizes steps involved in a method for treating an obesity patient by outputting electrical discharges from a HOP to selected portions of the patient's hypothalamus, according to a currently preferred embodiment of the invention. Thus, step **901** involves obtaining a three dimensional (digital) image of a patient's brain, the image including, and showing the position or location of the hypothalamus. Step **903** involves inserting a macrocatheter of a HOP (e.g. **1101'**, FIG. **27B**) adjacent to the hypothalamus. The macrocatheter may be introduced via an introducer tube (not shown) through a burr hole formed in the patient's cranium. At least one electrode support shaft is inserted into the hypothalamus in step **905**, wherein the at least one electrode support shaft bears a plurality of longitudinally arranged stimulation electrodes. Preferably step **905** involves inserting a plurality of electrode support shafts within the hypothalamus, each of the plurality of electrode support shafts bearing a plurality of longitudinally arranged stimulation electrodes, and each of the plurality of stimulation electrodes being capable of independent control, whereby a multitude of target areas or portions of the hypothalamus can be sampled following a single surgical procedure. Then, step **907** involves outputting electrical discharges from at least one of the plurality of stimulation electrodes, thereby stimu-

lating at least one neuron in the hypothalamus. Step **909** then involves observing and/or monitoring the clinical effect or clinical effects of step **907**. In this way, the entire hypothalamus may be mapped to determine those particular stimulation electrodes of the plurality of stimulation electrodes which will provide a clinically useful result or effect. Step **910** involves delivering electrical discharges from those particular stimulation electrodes of the plurality of stimulation electrodes determined in step **909** to provide a clinically useful result. The HOP may be programmed for the chronic output of suitable electrical discharges from those particular stimulation electrodes determined to provide a clinically useful result.

FIG. **32** is a schematic representation of steps involved in a method for treating an obesity patient, according to another embodiment of the invention, in which a three dimensional (digital) image of a patient's brain is obtained in step **901**. Step **903** then involves inserting a macrocatheter of a HOP (e.g. **1101'**, FIG. **27B**) adjacent to the hypothalamus, wherein the HOP includes a plurality of electrode support shafts. The plurality of electrode support shafts are inserted into a first region, or region I, of the hypothalamus in step **905**, wherein each of the plurality of electrode support shafts bear a plurality of longitudinally arranged stimulation electrodes. Then, step **907** involves stimulating a plurality of neurons in the first region of the hypothalamus by delivering electrical discharges from the plurality of stimulation electrodes. Step **909** then involves observing and/or monitoring the clinical effects of step **907**. If a useful clinical effect is not observed in step **909**, step **911** involves removing the plurality of electrode support shafts from region I of the hypothalamus, and reinserting the plurality of electrode support shafts, bearing a plurality of longitudinally arranged stimulation electrodes, into a second region, or region II, of the hypothalamus. Step **913** involves stimulating a plurality of neurons in region II of the hypothalamus by delivering one or more electrical discharges from the plurality of stimulation electrodes to neurons in region II. Step **915** involves observing and/or monitoring the clinical effects of step **913** to determine those particular stimulation electrodes of the plurality of stimulation electrodes which will provide a clinically useful result or effect. Based on the clinical effects observed in step **915**, step **917** involves delivering electrical discharges from those particular stimulation electrodes of the plurality of stimulation electrodes determined in step **915** to provide a clinically useful result. The HOP may be programmed for the chronic output of suitable electrical discharges from those particular stimulation electrodes determined to provide a clinically useful result.

It is to be understood that, according to the invention, a “region” of the hypothalamus may refer to a region or volume of the hypothalamus which lies in the vicinity of a single electrode support shaft **1105** and is “targeted” (or sampled) by that single electrode support shaft **1105**, or “region” of the hypothalamus may refer to a plurality of regions or volumes, wherein each of the plurality of regions or volumes is targeted simultaneously by a plurality of electrode support shafts **1105**.

By “region I” or “first region” of the hypothalamus is meant that region or group of regions targeted as a result of a first insertion of at least one electrode support shaft **1105** into the hypothalamus. By “region II” or “second region” of the hypothalamus is meant a second, third, or any additional number of randomly or otherwise selected regions targeted as a result of a corresponding second, third, or any additional number of insertions of at least one electrode support shaft **1105** into the hypothalamus.

FIG. 33 schematically summarizes steps involved in a method for treating an obesity patient by microinfusing a drug into one or more selected portions of the hypothalamus of a patient, according to another embodiment of the invention, wherein step 901 involves obtaining an image of the hypothalamus of the patient. Step 921 then involves inserting a macrocatheter into the patient's brain adjacent to the hypothalamus. The macrocatheter houses at least one microinfusion catheter. Each microinfusion catheter includes a plurality of independently controllable drug delivery ports, each of the plurality of drug delivery ports being functionally coupled to a drug supply line. Under the invention, the macrocatheter may be inserted adjacent to the hypothalamus via a burr hole in the patient's cranium, and the macrocatheter may be introduced into the patient's brain via an introducer tube (not shown) inserted into the burr hole. Step 923 involves inserting the at least one microinfusion catheter into the hypothalamus. Thereafter, step 925 involves sequentially infusing a drug from various members of the plurality of delivery ports on the at least one microinfusion catheter into corresponding sites of the hypothalamus proximate the various members of the plurality of delivery ports. Step 927 involves observing and/or monitoring the clinical effect of step 925, in order to determine which of the various members of the plurality of delivery ports will provide a useful clinical result. Finally, step 928 involves delivering a drug from those selected members of the plurality of delivery ports determined in step 927 to provide a useful or desired clinical effect.

FIG. 34 is a schematic representation of steps involved in a method for treating an obesity patient by microinfusing a drug from at least one microinfusion catheter into the hypothalamus of the patient, according to another embodiment of the invention. Thus, step 901 involves obtaining an image of the hypothalamus of the patient. Step 921 then involves inserting a macrocatheter into the patient's brain adjacent to the hypothalamus. Step 923 involves inserting at least one microinfusion catheter into a first region, or region I, of the hypothalamus. Step 925 involves sequentially infusing a drug from various members of the at least one drug delivery port on the at least one microinfusion catheter into a site within region I of the hypothalamus adjacent to the at least one drug delivery port. Step 927 involves observing and/or monitoring the clinical effect of step 925. In the event that a useful clinical effect is not observed in step 927, step 929 involves removing the at least one microinfusion catheter from region I of the hypothalamus and reinserting the at least one microinfusion catheter into a second region, or region II, of the hypothalamus. Step 931 involves sequentially infusing a drug from various members of the at least one drug delivery port on the at least one microinfusion catheter into a site within region II of the hypothalamus adjacent to the at least one drug delivery port. Step 933 involves observing and/or monitoring the clinical effect of step 931, in order to determine which of the various members of the plurality of delivery ports will provide a useful clinical result. Finally, step 935 involves delivering a drug to selected portions of the hypothalamus from those selected members of the plurality of delivery ports determined in step 933 to provide a useful or desired clinical effect.

Based on the clinical effect observed following microinfusion of certain drugs into specific sites within the hypothalamus a suitable drug treatment regimen may be instigated to effectively suppress the appetite of an obesity patient over a prolonged period of time. As a result an extended period of weight loss may be followed by a further

extended, or indefinite period, of more or less constant body weight in the normal range for an individual of the patient's height and bone mass.

FIG. 35A is a schematic representation of steps involved in a method for treating an obesity patient by electrical stimulation of the hypothalamus of the patient, according to a preferred embodiment of the invention. In step 1201 a three dimensional digital image of the patient's brain indicating the precise location of the hypothalamus is provided. Step 1203 involves forming a burr hole at an appropriate location in the patient's cranium. Step 1205 involves inserting an introducer tube into the burr hole; and step 1207 involves introducing a macrocatheter into the introducer tube. The macrocatheter may have a magnetic unit secured to the distal end of the macrocatheter, and the macrocatheter houses at least one electrode support shaft which includes a longitudinal arrangement of a plurality of stimulation electrodes. Step 1209 involves inserting the macrocatheter in a zone of the patient's brain adjacent to the hypothalamus. The inserting step 1209 may include magnetic stereotactic placement of the macrocatheter in a zone of the patient's brain adjacent to the hypothalamus, and the magnetic stereotactic placement of the macrocatheter may be performed under computer control.

Step 1211 involves inserting the at least one electrode support shaft into the hypothalamus. Step 1213 involves electrically stimulating at least one neuron in the hypothalamus, by means of electrical discharges of various frequencies, the electrical discharges outputted by, or delivered from, one or more of the plurality of stimulation electrodes. Step 1215 involves monitoring the clinical effect of step 1213 to define regions of the hypothalamus which will provide a desired clinical result when electrical discharges are outputted thereto. Step 1216 involves outputting or delivering electrical discharges to defined regions of the hypothalamus over a period of time commensurate with treatment for obesity. Depending on the patient's condition, the period of time for treatment may range from several days to several years. The defined regions of the hypothalamus to which electrical discharges are delivered are determined based on the clinical effects of electrical stimulation as monitored in step 1215.

FIG. 35B is a schematic representation of steps involved in a method for treating an obesity patient by microinfusing a drug from at least one microinfusion catheter into the hypothalamus of the patient, according to another embodiment of the invention. Steps 1201 to 1215 of the method of FIG. 35B are substantially as described above for steps 1201 to 1215 of the method of FIG. 35A. The method of FIG. 35B then includes the additional steps 1225 through 1233 as follows. Step 1225 involves removing the at least one electrode support shaft from the hypothalamus. Step 1227 involves removing the first macrocatheter from the zone of the patient's brain. Step 1229 involves inserting a second macrocatheter into the zone of the patient's brain whence the first macrocatheter was removed. The second macrocatheter inserted into the zone of the patient's brain includes or houses at least one microinfusion catheter, and the at least one microinfusion catheter has a longitudinal arrangement thereon of a plurality of drug delivery ports. Each of the plurality of drug delivery ports is capable of independently outputting or delivering a drug to a separate site within a given region of the hypothalamus. Step 1231 involves inserting the at least one microinfusion catheter of the second macrocatheter into the appropriate region of the hypothalamus, the appropriate region defined by observing a satisfactory or desired clinical effect when at least one

neuron within the appropriate region undergoes electrical stimulation, according to the clinical effect observed in step 1215. Step 1233 involves infusing a drug from at least one of the plurality of drug delivery ports to at least one site within the appropriate region of the hypothalamus.

FIG. 35C is a schematic representation of steps involved in a method for treating an obesity patient by microinfusing a drug from at least one microinfusion catheter into the hypothalamus of the patient, according to yet another embodiment of the invention. In step 1201 a three dimensional digital image of the patient's brain indicating the precise location of the hypothalamus is provided. Step 1203 involves forming a burr hole at an appropriate location in the patient's cranium. Step 1205 involves inserting an introducer tube into the burr hole; and step 1207 involves introducing a first macrocatheter into the introducer tube. The first macrocatheter may have a magnetic unit secured to the distal end of the first macrocatheter, and the first macrocatheter houses at least one electrode support shaft which includes a longitudinal arrangement of a plurality of stimulation electrodes. Step 1209 involves inserting the first macrocatheter in a zone of the patient's brain adjacent to the hypothalamus. The inserting step 1209 may include magnetic stereotactic placement of the first macrocatheter in a zone of the patient's brain adjacent to the hypothalamus, and the magnetic stereotactic placement of the first macrocatheter may be performed under computer control.

Step 1211 involves inserting the at least one electrode support shaft into a selected first region, or region I, of the hypothalamus. Step 1213 involves electrically stimulating at least one neuron in the selected first region of the hypothalamus, by means of electrical discharges outputted by or delivered from the plurality of stimulation electrodes. Step 1215 involves monitoring the clinical effect of step 1213. Step 1217 involves, first the removal of the at least one electrode support shaft from the selected first region of the hypothalamus, and then the reinsertion of the at least one electrode support shaft in a selected second region, or region II, of the hypothalamus. Step 1221 involves monitoring the clinical effect of step 1219. Step 1223 involves repeating steps 1217 through 1221 as appropriate until a satisfactory or desired clinical effect is obtained, and therefore an appropriate region for stimulation of at least one neuron within the hypothalamus may be defined. Step 1225 then involves removing the at least one electrode support shaft from the hypothalamus. Step 1227 involves removing the first macrocatheter from the zone of the patient's brain.

Step 1229 of FIG. 35C involves inserting a second macrocatheter into the zone of the patient's brain whence the first macrocatheter was removed. The second macrocatheter inserted into the zone of the patient's brain includes or houses at least one microinfusion catheter, and the at least one microinfusion catheter has a longitudinal arrangement thereon of a plurality of drug delivery ports. Each of the plurality of drug delivery ports is capable of independently outputting or delivering a drug to a separate site within a given region of the hypothalamus. Step 1231 involves inserting the at least one microinfusion catheter of the second macrocatheter into the appropriate region of the hypothalamus, the appropriate region defined by observing a satisfactory or desired clinical effect when at least one neuron within the appropriate region undergoes electrical stimulation, according to steps 1217 through 1223. Step 1233 involves infusing a drug from at least one of the plurality of drug delivery port to at least one site within the appropriate region of the hypothalamus.

FIG. 36A schematically shows steps involved in a method for treating an obesity patient by chronic electrical stimulation of the hypothalamus of the patient by implantation in the hypothalamus of a programmable hypothalamic obesity probe, according to a preferred embodiment of the invention. Step 1301 involves obtaining a three dimensional digital image of a patient's brain showing the location of the hypothalamus. Step 1303 involves inserting a macrocatheter into a zone of the patient's brain adjacent to the hypothalamus. The macrocatheter houses at least one electrode support shaft, and each of the at least one electrode support shafts has a plurality of stimulation electrodes. In turn, each of the plurality of stimulation electrodes is capable of independently outputting electrical discharges of various frequencies, for example at any given frequency over the range of from about 10 Hz to about 400 Hz. Step 1305 involves inserting the at least one electrode support shaft into the hypothalamus of the patient. Step 1307 involves delivering electrical discharges of various frequencies from a first set of the plurality of stimulation electrodes to a first set of neurons within the hypothalamus. Step 1309 involves delivering electrical discharges of various frequencies from at least one further set of the plurality of stimulation electrodes to at least one further set of neurons within the hypothalamus. In this regard, a "set" of stimulation electrodes may be a single member of the plurality of stimulation electrodes, located at a defined location on a defined member of the at least one electrode support shafts, which delivers an electrical discharge to a single site within the hypothalamus; or, a "set" of stimulation electrodes may include more than one member of the plurality of stimulation electrodes, each located at a defined location on one or more defined members of the at least one electrode support shafts, from which a plurality of electrical discharges are delivered simultaneously to a plurality of sites within the hypothalamus. By analogy, a "set" of neurons may be a single neuron targeted by an electrical discharge from a single stimulation electrode, or a "set" of neurons may include a plurality of neurons targeted simultaneously by a plurality of simultaneously transmitted or outputted electrical discharges from a corresponding plurality of stimulation electrodes. Step 1311 involves monitoring the clinical effects of steps 1307 and 1309 on appetite regulation by the patient, in order to determine the clinical effects of various combinations of electrical discharge frequency/location of stimulation electrodes. Such clinical effects may be monitored on the ward over a period of several hours, and subsequently over a more extended period of a number of days. Step 1313 involves optimizing the electrical discharges delivered to the neurons within the hypothalamus, according to steps 1307 and 1309, for optimum appetite regulation by the patient. As alluded to above, step 1313 may include optimizing both the frequency of the electrical discharges over an extended frequency range from about 10–400 Hz, and the set of stimulation electrodes from which the electrical discharges are outputted. In the latter case, the set of stimulation electrodes from which the electrical discharges are outputted correspond, or directly relate to, specific target sites or regions within the hypothalamus. Step 1314 involves programming the HOP for chronic delivery of selected electrical discharges, of defined frequency and at specific locations within the hypothalamus, as determined in step 1313 to provide optimum appetite regulation.

FIG. 36B schematically shows steps involved in a method for treating an obesity patient by chronic electrical stimulation of the hypothalamus of the patient by implantation in the hypothalamus of a pre-programmed chronic electrical

49

stimulator, according to another embodiment of the invention. Steps 1301 to 1313 of the method of FIG. 36B are common to the method of FIG. 36A as described above. Step 1315 involves pre-programming a chronic electrical stimulator for optimum clinical effectiveness in the patient, based on the results of step 1313. Lastly, step 1317 involves implanting the pre-programmed chronic electrical stimulator in an appropriate location within the hypothalamus of the patient.

EXAMPLE 1

Method of Performing Magnetic Stereotactic Pallidotomy

Introducer tube 101 is stereotactically inserted through a burr hole in the patient's skull such that the open distal end 107 of introducer tube 101 is positioned close to the lateral globus pallidus. A dual purpose multicontact electrode assembly 103 including a flexible electrode support shaft 137 having a magnetic tip 133 is inserted into introducer tube 101, such that magnetic tip 133 of support shaft 137 is approximately in a desired location within the patient's brain. The patient is brought to the magnetic surgery suite, and electrode support shaft 137 of electrode assembly 103 is magnetically pulled into the globus pallidus, generally along the long axis of the globus pallidus, along a preselected trajectory. Once electrode support shaft 137 is suitably positioned to occupy the desired volume within the globus pallidus, the patient is removed from the magnetic surgery suite and returned to the hospital ward. While on the ward, the physiological activity of a number of globus pallidus neurons is monitored using bipolar microelectrodes 135A. Based on the recordings of physiological activity thus obtained and on criteria of physiologically normal parameters, radio frequency lesions are made at the site of those neurons targeted for inactivation, by energizing the appropriate macroelectrode(s) 139 with a lesion-producing electric current. The functional consequences of the newly-formed lesions are assessed on the ward by testing the patient prior to removal of electrode assembly 103 from the patient. If the results are satisfactory, the electrode assembly is removed. If it is desirable to monitor, and potentially lesion, additional neurons located within a different volume of the globus pallidus, electrode assembly 103 is retracted into introducer tube 101. The patient is returned to the magnetic surgery suite, and the process is repeated until a satisfactory result is achieved.

EXAMPLE 2

Targeted Drug Delivery from a Dual Purpose Electrode Assembly for the Treatment of Epilepsy

Introducer tube 101 is stereotactically inserted through a burr hole in the patient's skull such that the open distal end 107 of introducer tube 101 is positioned within the cerebral cortex. A dual purpose neuron-monitoring/drug delivery electrode assembly 103 including a flexible electrode support shaft 137 having a magnetic tip 133 is inserted into introducer tube 101, such that the magnetic tip 133 of support shaft 137 is approximately in a desired location within the patient's skull. The patient is brought to the magnetic surgery suite, and electrode support shaft 137 of electrode assembly 103 is magnetically manipulated until it occupies the desired position. Once electrode support shaft 137 is suitably positioned, the patient is removed from the magnetic surgery suite and taken to the epilepsy monitoring unit, where the physiological activity of a number of neurons

50

is monitored. Based on the recordings of physiological activity thus obtained and on criteria of physiologically normal parameters, a suitable dose of one or more therapeutic drugs is released from one or more selected drug delivery ports 141.

The functional consequences of drug treatment is assessed in the epilepsy monitoring unit by testing the patient prior to removal of dual purpose electrode assembly 103. If the results are satisfactory, electrode assembly 103 is removed from the patient. If it is desirable to monitor, and potentially administer a therapeutic drug to, one or more different regions of the cerebral cortex, electrode assembly 103 is retracted into introducer tube 101. The patient is then returned to the magnetic surgery suite, and the process is repeated until a satisfactory result is achieved.

As will be apparent to the skilled artisan, the apparatus of the instant invention is particularly suited to performing surgery on the brain, in general, and may be used effectively for performing other medical procedures, including but not limited to, thalamotomy, controlled lesioning to treat epilepsy, and targeted delivery of therapeutic drugs.

EXAMPLE 3

Method for Treating Obesity by Hypothalamic Electro-Stimulation

A burr hole is strategically placed in the patient's cranium for the purpose of stereotactic placement of a macrocatheter of the hypothalamic obesity probe apparatus in a zone of the patient's brain adjacent to the hypothalamus. An introducer tube is stereotactically inserted through the burr hole. The macrocatheter, which includes a magnetic collar affixed at the distal end of the macrocatheter, is inserted into the introducer tube. The patient is transferred to the magnetic surgery suite, and the magnetically equipped macrocatheter is magnetically manipulated such that it is positioned adjacent to the hypothalamus. (At this point the patient may be removed from the magnetic surgery suite). At least one electrode support shaft bearing a plurality of stimulation electrodes is introduced from the macrocatheter into a first region of the hypothalamus. Because the plurality of stimulation electrodes are arranged longitudinally on the at least one electrode support shaft, each of the plurality of stimulation electrodes occupies a distinct position within the hypothalamus. Each of the plurality of stimulation electrodes is capable of being independently controlled, i.e. each of the plurality of stimulation electrodes is capable of independently outputting electrical discharges over a range of frequencies. Following implantation of at least one electrode support shaft into the hypothalamus, the patient is transferred to the ward for electrical stimulation trials. Electrical discharges of relatively high or low frequency are delivered independently from selected members of the plurality of stimulation electrodes, and the clinical effects are observed. The specific contacts or stimulation electrodes from which electrical discharges are delivered, and the frequencies of the electrical discharges, are varied in order to determine which combination(s) of stimulation electrodes/electrical discharge frequency provide a desired or optimal clinical effect. That is to say, the effects on appetite suppression of electrical stimulation of neurons at a set of locations within the hypothalamus by electrical discharges of specific frequency/frequencies delivered from a corresponding set of stimulation electrodes are observed and recorded. Such observations are made initially over a period of a few hours, and subsequently over a period of several

days, as necessary. If the clinical effects observed are deemed unsatisfactory by the physician, a different combination of stimulation electrodes/electrical discharge frequency may be used. That is to say, specific sets of neurons of the hypothalamus are stimulated by electrical discharges of different frequency/frequencies and/or by electrical discharges from different stimulation electrodes of the at least one electrode support shaft, and the effects on appetite suppression are again observed and recorded.

Once the clinical effects of hypothalamic electrical stimulation are deemed satisfactory by the physician, the hypothalamic obesity probe may be programmed to provide chronic electrical discharges from those stimulation electrodes and at those frequencies observed to provide a satisfactory clinical effect.

EXAMPLE 4

Method for Treating Obesity by Hypothalamic, Site-Specific Drug Microinfusion

A magnetically tipped first macrocatheter, which houses at least one microinfusion catheter, is inserted into a zone of the patient's brain adjacent to the hypothalamus, generally as described above for EXAMPLE 3. At least one microinfusion catheter, bearing a plurality of independently controllable drug delivery ports, is introduced into the hypothalamus. The clinical effects of various sequentially-administered drug delivery regimens are monitored; each regimen including a given dosage of a drug delivered from specific members of the plurality of drug delivery ports. The clinical effects of a given drug treatment regimen may be monitored over a period of hours or days. In this way it is possible to define one or more regions of the hypothalamus that is involved in appetite regulation, the one or more regions so defined corresponding to a set of the plurality of drug delivery ports.

The at least one microinfusion catheter is coupled to a miniature surgical drug reservoir/pump via surgical tubing using materials and methods well known in the art. The reservoir/pump is secured to the patient's cranium beneath the scalp, and the reservoir/pump is activated to pump a drug, known to regulate appetite when delivered within the hypothalamus, from a defined set of the plurality of drug delivery ports. The rate at which the reservoir/pump pumps a drug may be adjusted empirically in order to obtain the optimum clinical effect.

The Risk Benefit Ratio

i. Neural Prosthesis Risk/Benefit

The clinical usefulness of an auditory neural prosthetic device depends on several variables, most importantly the risk-benefit ratio for a given device. An ideal device effectively restores hearing without risk to the patient's overall health. Salient features of two types of devices are outlined below.

Since primary auditory cortex **150** is situated in temporal lobe **156**, neurosurgeons expose this portion of the brain routinely during a wide range of operations. In the non-dominant temporal lobe, unlike the brainstem, the auditory region is not surrounded by vital structures. If a patient is diagnosed with an infiltrating tumor of the non-dominant auditory cortex, for example, the neurosurgeon can resect this tissue with very little risk of complication.

Another example is temporal lobe surgery for intractable epilepsy. Most patients who undergo this surgery are in good general health but suffer from seizures periodically. Usually,

chronic epilepsy is not a life threatening condition, and many patients have seizures for decades during which time they are able to work and raise families.

Since most forms of epilepsy are medically "tolerable," surgical treatment directed at curing epilepsy is only justified when it is highly effective and carries with it very low risk of morbidity and mortality. A properly selected patient in good general health has less than a one percent chance of developing a significant neurologic complication following an elective non-dominant temporal lobectomy for intractable epilepsy, and a 70 percent chance of being cured of their seizures. In that setting, the risk/benefit ratio is strongly in the patient's favor. An operation designed exclusively to place a stimulating neural prosthetic electrode onto non-dominant auditory cortex could be carried out under local anesthesia and take less than two hours operating time. This procedure would entail even less medical risk than a standard epilepsy resection.

ii. Magnetic Pallidotomy Risk/Benefit

Compared with prior art stereotactic pallidotomy, magnetic pallidotomy according to the instant invention has, in theory, less risk and greater benefit to the patient, for the following reasons. Because of the ability of the electrode support shaft to be directed to occupy a specific conformation within the target tissue and the presence of a plurality of neuron-monitoring microelectrodes, a target volume of the globus pallidus can be accessed, and neurons from a number of sites within that target volume can be monitored with a single pass through the brain. In contrast, neuron-monitoring electrodes of the prior art would need to be passed through the brain a number of times to access an equivalent volume of target tissue.

Secondly, by combining the functions of neuron-monitoring and lesion-production in a single dual purpose electrode assembly, according to the invention, the need for replacing a neuron-monitoring electrode support with a lesion-producing electrode support is eliminated, and consequently the risk of error in electrode support misplacement is also eliminated.

Furthermore, the safety and efficacy of pallidotomy is strongly influenced by the ability to effectively monitor and assess brain tissue being considered for inactivation. The ability to monitor a number of neurons over an extended period of time, on the ward, allows for the gathering of more precise information on the physiologic status of each neuron, and a more informed decision to be made on which regions of the tissue are to be targeted for lesion production.

iii. HOP Risk/Benefit

One potential or apparent drawback to use of the HOP in obesity treatment may be the public perception of stereotactic probe placement within the brain as a high risk procedure. In reality, statistics indicate that electrode implantation within the human brain is a low risk procedure. Therefore, the risks of mortality and morbidity associated with morbid obesity probably greatly exceed those associated with electrode implantation. On this basis, the use of the HOP for the treatment of morbid obesity can be justified as having a low risk/benefit ratio.

The foregoing embodiments are merely exemplary and are not to be construed as limiting the present invention. The present teaching can be readily applied to other types of apparatuses. The description of the present invention is intended to be illustrative, and not to limit the scope of the claims. Many alternatives, modifications, and variations will be apparent to those skilled in the art.

53

What is claimed is:

1. A drug infusion device, comprising:
a macrocatheter; and
a plurality of microinfusion catheters disposed non-co-axially side-by-side within the macrocatheter, wherein at least one microinfusion catheter comprises a plurality of drug delivery ports and is configured to receive a drug and infuse the drug into a tissue of a patient, and wherein the plurality of drug delivery ports comprises individually controllable drug delivery ports.
2. A drug infusion device, comprising:
a plurality of microinfusion catheters disposed non-co-axially side-by-side with respect to one another and configured to receive a drug and infuse the drug into a tissue of a patient, wherein at least one microinfusion catheter comprises a plurality of individually controllable drug delivery ports disposed along a length of the at least one microinfusion catheter; and
a macrocatheter configured to house the plurality of microinfusion catheters.
3. The drug infusion device of claim 2, wherein the tissue comprises the hypothalamus.
4. The drug infusion assembly of claim 2, wherein the macrocatheter comprises a magnet configured to cooperate with an external magnetic field to guide the macrocatheter.
5. A drug infusion assembly comprising the drug infusion device of claim 2, and further comprising a pump configured to deliver the drug to at least one microinfusion catheter of the plurality of microinfusion catheters.
6. The drug infusion assembly of claim 5, wherein the pump is configured to be controlled percutaneously.
7. The drug infusion assembly of claim 5, further comprising a manifold configured to convey the drug from the pump to the at least one microinfusion catheter.
8. A drug infusion device, comprising:
a macrocatheter; and
a plurality of microinfusion catheters disposed non-co-axially side-by-side within the macrocatheter, wherein at least one microinfusion catheter of the plurality of microinfusion catheters is movable and comprises a plurality of individually controllable drug delivery ports, wherein the at least one microinfusion catheter is configured to receive a drug and infuse the drug into a tissue of a patient, and wherein the macrocatheter comprises a magnet configured to aid in the stereotactic placement of the macrocatheter in the tissue.
9. The drug infusion assembly of claim 1, wherein the magnet comprises a magnetic collar disposed on the macrocatheter proximate to an end of the macro catheter.
10. A drug infusion device, comprising:
a macrocatheter;
a plurality of microinfusion catheters disposed non-co-axially side-by-side within the macrocatheter, wherein at least one of said plurality of microinfusion catheters comprises a plurality of drug delivery ports and is configured to receive a drug and infuse the drug into a tissue of a patient; and
at least one pump configured to controllably supply the drug to the at least one microinfusion catheter, wherein the at least one pump is configured to be controlled percutaneously.
11. The drug infusion assembly of claim 10, further comprising a manifold configured to convey the drug from the at least one pump to the at least one microinfusion catheter.

54

12. A drug infusion device, comprising:
a plurality of microinfusion catheters disposed non-co-axially side-by-side with respect to one another and configured to receive a drug and infuse the drug into the hypothalamus of a patient;
a pump configured to controllably supply a drug to the plurality of microinfusion catheters; and
a manifold configured to convey the drug from the pump to the plurality of microinfusion catheters, wherein at least one microinfusion catheter comprises multiple individually controllable drug delivery ports disposed along a length of the at least one microinfusion catheter.
13. A drug infusion device, comprising:
a plurality of microinfusion catheters disposed non-co-axially side-by-side with respect to one another and configured to receive a drug and infuse the drug into a hypothalamus of a patient;
at least one electrode configured to sense electrical activity of the hypothalamus;
a pump configured to controllably supply a drug to the plurality of microinfusion catheters, wherein the pump is configured to communicate with the at least one electrode and supply the drug to at least one of the plurality of microinfusion catheters in accordance with the electrical activity of the hypothalamus; and
a manifold configured to convey the drug from the pump to the plurality of microinfusion catheters.
14. A drug infusion assembly for microinfusing a drug into the hypothalamus of a patient's brain, comprising:
a plurality of microinfusion catheters disposed non-co-axially side-by-side with respect to one another and configured to be inserted into the hypothalamus of a patient's brain, wherein at least one microinfusion catheter of said plurality of microinfusion catheters comprises a plurality of drug delivery ports arranged such that each drug delivery port of the plurality of drug delivery ports is configured to deliver a drug to a separate site within the hypothalamus;
a macrocatheter for housing the plurality of microinfusion catheters;
a drug delivery manifold, wherein each of said plurality of microinfusion catheters is functionally coupled to said drug delivery manifold;
a drug supply line functionally coupled to said drug delivery manifold; and
a drug reservoir and pump for retaining and for pumping a drug, said drug reservoir and pump being functionally coupled to said drug supply line, wherein said drug reservoir and pump are capable of pumping a drug at a variable rate, and the variable rate can be controlled percutaneously.
15. The drug infusion assembly as claimed in claim 14, wherein said macrocatheter includes a magnetic unit, said magnetic unit being configured such that application of an external magnetic field allows for stereotactic placement of said macrocatheter to a specific location within the patient's brain.
16. The drug infusion assembly as claimed in claim 14, wherein said macrocatheter includes a magnet located at a distal end of said macrocatheter.
17. The drug infusion assembly as claimed in claim 14, wherein said drug reservoir and pump are capable of pumping a drug at a variable rate.
18. The drug infusion assembly as claimed in claim 14, wherein said drug reservoir and pump include a recharge valve for recharging said drug reservoir and pump with a drug.

55

19. The drug infusion assembly as claimed in claim 18, wherein said recharge valve is accessible percutaneously.

20. The drug infusion assembly as claimed in claim 14, wherein the drug reservoir and pump contains and supplies an appetite controlling drug for treating obesity.

21. The drug infusion assembly as claimed in claim 14, wherein at least one microinfusion catheter of the plurality of microinfusion catheters is configured such that each of the plurality of drug delivery ports can be independently controlled.

22. The drug infusion assembly as claimed in claim 14, further comprising monitoring electrodes which sense electrical activity within the patient's hypothalamus.

23. The drug infusion assembly as claimed in claim 22, wherein the at least one microinfusion catheter of the plurality of microinfusion catheters is configured to independently deliver a drug from each of the plurality of drug delivery ports of the at least one microinfusion catheter based on information gathered from the monitoring electrodes.

24. The drug infusion assembly of claim 14, wherein the plurality of drug delivery ports is disposed along a length of the at least one microinfusion catheter.

25. The drug infusion assembly as claimed in claim 14, wherein said drug reservoir and said pump comprise a combined drug reservoir and pump.

26. A drug infusion device, comprising:
a macrocatheter;

a plurality of microinfusion catheters extending through the macrocatheter and movably disposed non-coaxially side-by-side with respect to one another, wherein each of the plurality of microinfusion catheters is configured to receive a drug, and wherein an end portion of each of the plurality of microinfusion catheters is configured to extend beyond an end of the macrocatheter so as to infuse the drug into the hypothalamus of a patient;
a pump configured to controllably supply a drug to the plurality of microinfusion catheters;
a manifold configured to convey the drug from the pump to the plurality of microinfusion catheter; and
at least one electrode configured to sense electrical activity of the hypothalamus, wherein the pump is configured to communicate with the at least one electrode and supply the drug to at least one of the plurality of microinfusion catheters in accordance with the electrical activity of the hypothalamus.

27. The drug infusion assembly of claim 26, wherein the pump can be controlled percutaneously.

28. The drug infusion assembly of claim 26, wherein at least one microinfusion catheter comprises multiple individually controllable drug delivery ports disposed along a length of the at least one microinfusion catheter.

29. The drug infusion assembly of claim 26, wherein the macrocatheter comprises a magnet.

30. The drug infusion assembly of claim 26, wherein the drug is configured to affect the weight of the patient.

31. A drug infusion device, comprising:

a macrocatheter, comprising a magnet configured to aid in the stereotactic placement of the macrocatheter, wherein the magnet comprises a magnetic collar disposed on the macrocatheter proximate to an end of the macrocatheter; and

a plurality of microinfusion catheters disposed non-coaxially side-by-side within the macrocatheter, wherein at least one of said plurality of microinfusion catheters comprises a plurality of drug delivery ports and is configured to receive a drug and infuse the drug into a

56

tissue of a patient, and wherein at least one of said plurality of microinfusion catheters is movable within said macrocatheter.

32. The drug infusion device of claim 31, wherein the plurality of drug delivery ports comprises individually controllable drug delivery ports.

33. The drug infusion device of claim 31, wherein the plurality of drug delivery ports are disposed along a length of the at least one microinfusion catheter.

34. A drug infusion assembly comprising the drug infusion device of claim 31, and further comprising at least one pump configured to controllably supply the drug to the at least one microinfusion catheter.

35. The drug infusion assembly of claim 34, wherein the at least one pump is configured to be controlled percutaneously.

36. The drug infusion assembly of claim 34, further comprising a manifold configured to convey the drug from the at least one pump to the at least one microinfusion catheter.

37. A drug infusion assembly for microinfusing a drug into the hypothalamus of a patient's brain, comprising:

a plurality of microinfusion catheters disposed non-coaxially side-by-side with respect to one another and configured to be inserted into the hypothalamus of a patient's brain, wherein at least one microinfusion catheter of said plurality of microinfusion catheters comprises a plurality of drug delivery ports arranged to deliver a drug to a separate site within the hypothalamus;

a drug delivery manifold, wherein each of said plurality of microinfusion catheters is functionally coupled to said drug delivery manifold;

a drug supply line functionally coupled to said drug delivery manifold; and

a drug reservoir and pump for retaining and pumping a drug, said drug reservoir and pump being functionally coupled to said drug supply line, wherein said drug reservoir and pump includes a recharge valve for recharging said drug reservoir and pump with a drug.

38. The drug infusion assembly as claimed in claim 37, wherein said recharge valve is accessible percutaneously.

39. The drug infusion assembly as claimed in claim 37, wherein said drug reservoir and said pump comprise a combined drug reservoir and pump.

40. A drug infusion assembly for microinfusing a drug into the hypothalamus of a patient's brain, comprising:

a plurality of microinfusion catheters disposed non-coaxially side-by-side with respect to one another and configured to be inserted into the hypothalamus of a patient's brain, wherein at least one microinfusion catheter of said plurality of microinfusion catheters comprises a plurality of drug delivery ports arranged to deliver a drug to a separate site within the hypothalamus;

a drug delivery manifold, wherein each of said plurality of microinfusion catheters is functionally coupled to said drug delivery manifold;

a drug supply line functionally coupled to said drug delivery manifold; and

a drug reservoir and pump for retaining and pumping a drug, said drug reservoir and pump being functionally coupled to said drug supply line, wherein at least one microinfusion catheter of the plurality of microinfusion catheters is configured such that each of the plurality of drug delivery ports can be independently controlled.

57

41. The drug infusion assembly as claimed in claim 40, wherein said drug reservoir and said pump comprise a combined drug reservoir and pump.

42. A drug infusion assembly for microinfusing a drug into the hypothalamus of a patient's brain, comprising:
5 a plurality of microinfusion catheters disposed non-co-axially side-by-side with respect to one another and configured to be inserted into the hypothalamus of a patient's brain, wherein at least one microinfusion catheter of said plurality of microinfusion catheters
10 comprises a plurality of drug delivery ports arranged to deliver a drug to a separate site within the hypothalamus;
15 a drug delivery manifold, wherein each of said plurality of microinfusion catheters is functionally coupled to said drug delivery manifold;

58

monitoring electrodes that sense electrical activity within the patient's hypothalamus;
a drug supply line functionally coupled to said drug delivery manifold; and
5 a drug reservoir and pump for retaining and pumping a drug, said drug reservoir and pump being functionally coupled to said drug supply line, wherein the at least one microinfusion catheter is configured to independently deliver a drug from each of the plurality of drug
10 delivery ports based on information gathered from the monitoring electrodes.
43. The drug infusion assembly as claimed in claim 42, wherein said drug reservoir and said pump comprise a combined drug reservoir and pump.

* * * * *